

MOSO[®] facade fixings for masonry walls

MOSO[®] perforated strip

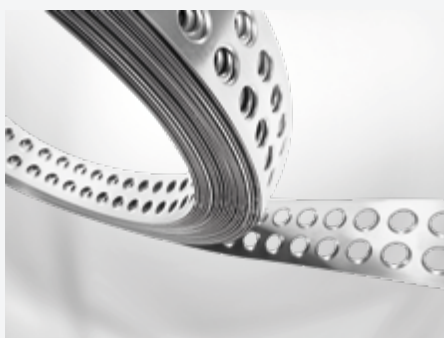

Single-bracket anchors



Angle support brackets



Scaffold anchors



Fixings for precast parts



Wall ties





**With us you create lasting connections,
with MOSO® masonry support and retaining anchor systems, now worldwide as part of Leviat!**

Dear ladies and gentlemen,
dear client and structural engineer,

We are still the supply and service partner for our customers in the field of masonry fasteners that you have known and also come to appreciate over the years. And that will not change!

With the expanded possibilities in a large building materials group, we can now even expand our service possibilities. New colleagues are trained on our MOSO® fastening system and made fit with our special, self-developed software programmes for the expansion of consulting and fast processing.

The use of Lean Duplex steel and also the new MOSOTherm insulation material with its force-transmitting properties will be expanded at the approximately 60 locations of the fastening specialist Leviat. This means that, overall, Modersohn's concepts, which have been tried and tested for years, are being used and expanded.

Let our engineers and technicians advise you as usual.

Yours

Wilhelm Modersohn jr.



Wilhelm Modersohn
(Board member
Information centre
Stainless Steel)

The history

- Foundation of the company on 24 March 1970 by Wilhelm Modersohn sen., until then an independent representative for fastening systems at the company Lutz in Wertheim.



- 1974:
Rental of office and storage space.

- 1979:
Rental of an empty factory building to expand the company's own production. Simple welding work is also carried out here.

- 1984:
Construction of our own production hall in the nearby industrial estate.



- End of the 90s:
Expansion of the production facilities for the manufacturing of special and series parts made of stainless steel for other industries.

- 2000:
Wilhelm Modersohn jun. takes over the management of the company.

- 2008 / 2009:
Construction of a new administration building for the service centre Sales and the work preparation department. Furthermore, production and dispatch are expanded.

- 2014:
Dipl.-Ing. Jürgen Matzelle is appointed technical managing director.

- 2015:
Expansion of the administration building on Industriestrasse.

- 2016:
Move into the new administration building.



- 2017:
Purchase of the former Aldi store in the neighbourhood, expansion of the open-air and pre-material warehouse.

- 2019:
New construction of a hall for surface treatment.

- 2020:
Commissioning of the new welding robot. Furthermore, Modersohn celebrates its 50th anniversary.

- 2021:
Investment in two press brakes and an 8 kW fibre laser.

- MODERSOHN becomes a part of Leviat.

The products



MOSO® perforated strip

LB

Page



The first off-roll reinforcement. For universal application. In stainless steel or galvanised.

• Reinforcement from the reel		6
• Self-supported lintel reinforcement		7
• For large lintel openings		8
• Constructive masonry reinforcement		9/10

MOSOTerm

MT



Effective reduction of thermal bridges.

• Thermal separation for facade systems	MT	12-14
• Point thermal transmittance χ		13

Single bracket anchors

EK



The universal anchor for masonry facades. Available for fast delivery. Easy to install. Proven for years.

• Adjustable pressure screw	EK-D	16/17
• Universal anchor	EK-U	18/19
• The flexible solution for small loads	EK-W	20/21
• With longer support	EK-L	22/23
• For lintels with low brickwork heights	EK-G	24/25
• Special brackets	EK-S	26

Angle support brackets

WK



The systematic special solution for any fixing situation. Our engineering team is happy to advise you.

• Adjustable pressure screw	WK-D	28/29
• Standard angle support bracket	WK-N	30/31
• For wall bracing at corners and pillars	WK-Z	32/33
• Special brackets	WK-S	34

Angle bearings

WA



The solution for simple fixing situations. Even customised solutions are available at short notice.

• For covering masonry openings	WA-Ü	36/37
	WA-Z	
• For a closed view from below	WA-D	38/39
	WA-M	
• Special designs	WA-S	40

Fixing for precast parts

FB



Do you produce pre-cast lintels, or do you need to install these? We offer a number of tried and tested solutions.

• Adjustable pressure screw	FB-D	42/43
• Universal anchors for precast lintels	FB-U	44/45
• Special designs	FB-S	46

Wall ties

HV



For perfect facade support against tipping, while taking account of heat flows.

• MOSO® wind post fixings	HV-WP	48/49
• Brackets for fascia facing	HV-A	50/51
• Wire anchors for subsequent fastening	HV-D	52/53
• Air layer eyelet anchor for subsequent fastening	HV-L	54/55
• Special designs	HV-S	56

Scaffold anchors

GA



To remain in the masonry facade. These anchors can be re-used again and again. Made from high-quality stainless steel.

• Scaffold anchors for masonry facades	GA-Q	58/59
	GA-Z	
• Special solutions	GA-S	60

Bracket variants

VA



Standardised special brackets for interception constructions in modern construction

• U-profile brackets	FB-G / WK-U	62/63
• High load transfer with low component heights	MO-DA	64/65
• Vertical anchoring direction	WK-I / FB-I	66/67
• Special solutions	Sonder	68/69
• Corners and edging / Abutments in corner areas		70

Accessories

ZU



With us you get everything from a single source. From the suitable dowels to effective vermin protection. We help you.

• Anchor channels for precast concrete lintels	MBA-ES	72/73
• Accessories		74-77
• Corrosion resistance classes	CRC IV	78

Technical details

TD



Our service - your success! The technology of masonry support and reinforcement briefly and concisely presented.

• Dowel systems	Connection anchors	80
	Anchor bolts	81
	Frame anchors	82
	Composite mortar	82
• MOSO® CE anchor channel	MBA-CE	83
• Technical specifications for masonry support		84/85
• Technical specifications for expansion joint arrangement		86/87
• Installation instructions for MOSO® precast fixing FB-DV 4,0 / 8,0 kN		88
• Installation instructions for MOSO® angle support bracket WK-NV 4,0 / 8,0 kN		89
• Dimensioning principles		90
• Surface treatment		91

The following applies to all products in this catalogue: The specified intended uses only represent the key area. Our technicians are happy to provide you with any further explanation.



Complete system solutions for concrete facade anchors



... as well as customised special solutions

NiroFix® - The experts for stainless steel

- ▲ Special heavy duty fixings for tunnels and bridges
- ▲ Renovation of old buildings, fortifications for churches, castles and palaces
- ▲ Custom-made products and special constructions
- ▲ Industrial parts

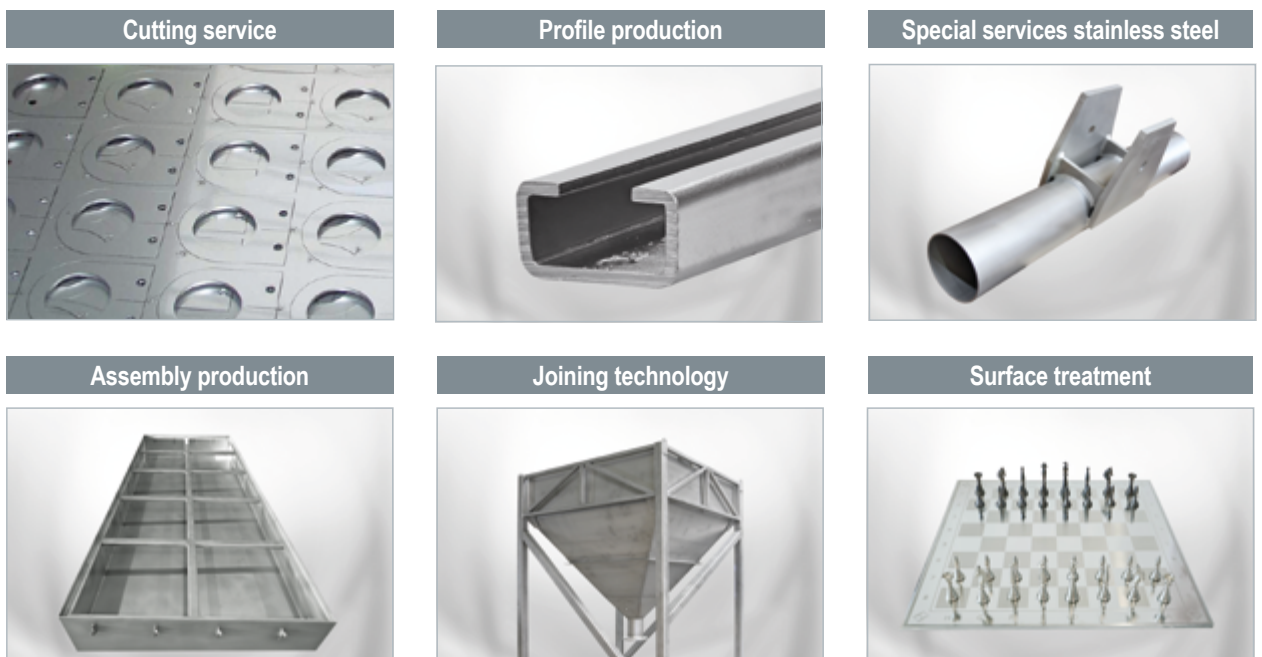

ASK FOR OUR SEPARATE CATALOGUES! TEL +49 5225 87 99-0 | email info@modersohn.de

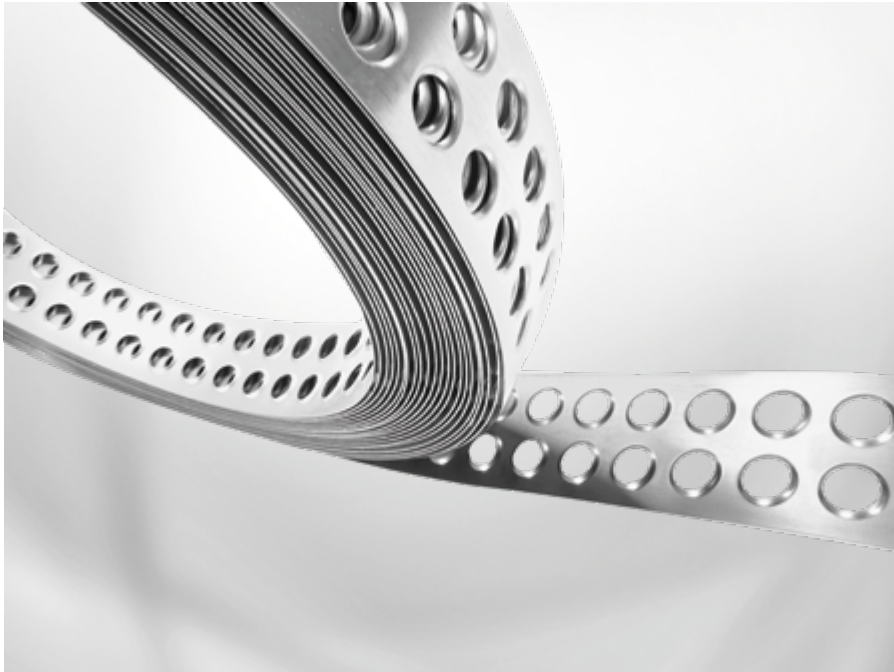

MOSO® Perforated strip



MOSO® perforated strip – Reinforcement from the reel

The MOSO® perforated strip was developed to realise self-supporting lintels over door and window openings.

It can be used to reinforce grenadian layers, as well as stretcher courses and 1½-fold grenadian layers.

Another key area of application is constructive crack safeguarding, to secure buildings permanently against unsightly visible cracks, minimise warranty claims, and - above all: to make bricklaying as easy as possible.

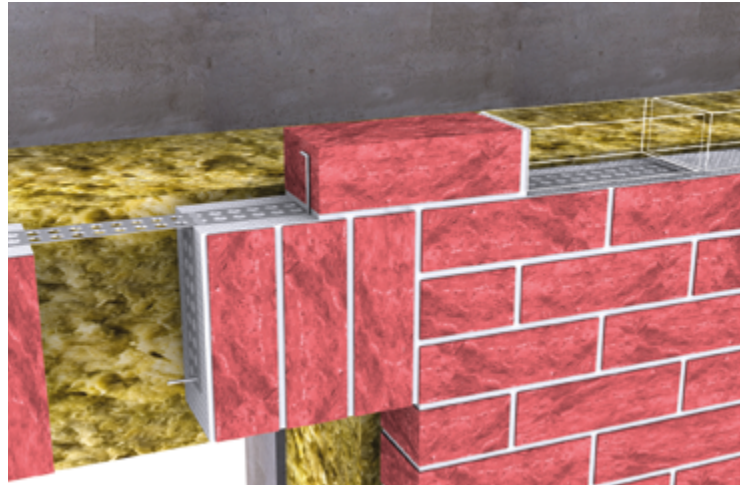

▲ MOSO® perforated strip as approved self-supporting lintel reinforcement

Use and application

- Self-supporting lintel reinforcement
- Wall connection from masonry wall to masonry wall
- Crack safeguard at window and door openings, vertical walls with point loads, and connected structural components of different heights.

Easy to use



▲ Convenient on-site transport



▲ Simply pull it out of the box...



▲ ... cut with plate shears



▲ Required accessories user friendly packed

Perforated strip length	Lintel reinforcement		Constructive crack safeguard		
	E 420 (high-tensile stainless steel)	E 235 (stainless steel)	Steel (galvanised)	Thin bed stainless steel	Thin bed steel (galvanised)
	Item no.	Item no.	Item no.	Item no.	Item no.
25 m (box)	6005000	600300	600100	600200	600250
50 m (box)	6005100	600310	600110	600210	600260
10 m (box)		6600305			

Perforated tape stay	Packaging unit	Item no.
050 (heading course)*	100 pieces	6006600
090 (upright course of bricks)	100 pieces	6006000
190 (brick-on-edge course)	100 pieces	6006100
310 (1.5 times brick-on-edge course)*	50 pieces	6006500

* not part of the approval

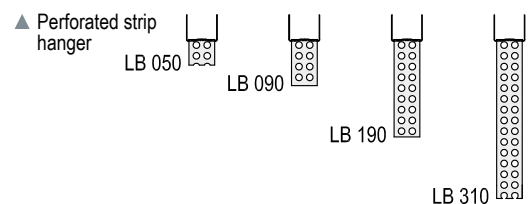

Mounting accessories (applications - see assembly instructions)	Packaging unit	Item no.
Back anchor bracket for transmission of force in the pressure zone	100 pieces	600620
Round bar 4 x 250 mm for pinning of brick courses	100 pieces	600630

MOSO® perforated strip as self-supporting lintel reinforcement

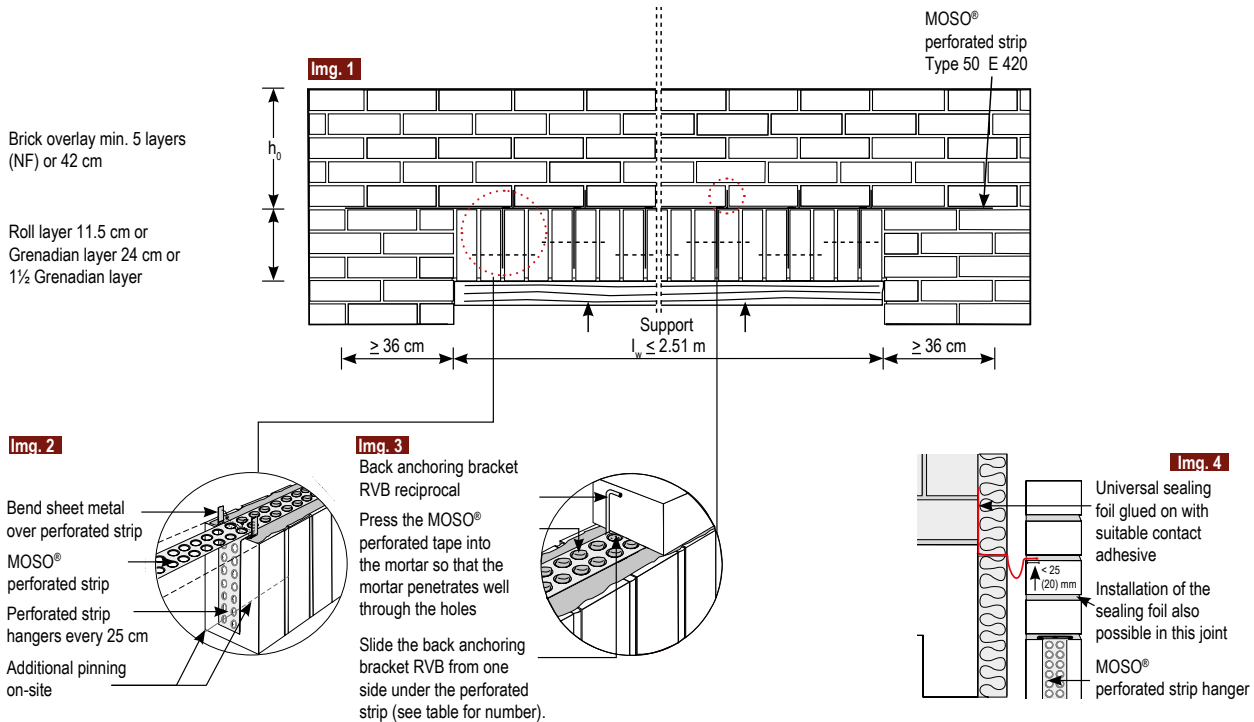

Handling MOSO® perforated strip



▲ Install perforated tape hangers...



▲ ... on the bricks during bricklaying

- Unroll MOSO® perforated strip off the roll and cut it with the hand shears
Cutting length = clear width of the lintel + 2 x 36 cm
- Brick the rolling or boundary layer with full joints and install the perforated strip hangers at a distance of ≤ 25 cm.
- Apply mortar for the heading layer thickly
- Place MOSO® perforated strip and press into the mortar bed
- Bend the sheet ends of the MOSO® perforated tape hangers over the perforated strip
- Brick the stretcher course and, for lintels $l_w \geq 1.51$ m, insert the MOSO® back anchoring brackets alternately with one leg under the perforated strip at a distance of ≤ 25 cm into the butt joints.
- The lintel is to be supported until the mortar has hardened
- Please note: The minimum brick height h_0 above the MOSO® perforated strip is 5 layers NF (≥ 42 cm).

Tender text

Delivery and professional installation of ... m lintel support with MOSO® perforated strip **type 50 E 420** for clear span of ... m, facing brick format ..., lintel height ... cm, incl. additional allowance.



▲ ... and place MOSO® perforated tape between the hangers after completing the Grenadian layer. Then simply bend the perforated tape hangers closed. Finished!

Material requirements per lintel ①

Width of opening l_w [m]	1.01	1.26	1.51	1.76	2.01	2.26	2.51
Cutting length of perforated strip [m]	1.73	1.98	2.23	2.48	2.73	2.98	3.23
Quantity of perforated tape stays (...)	4	5	6	7	8	9	10
Quantity of rear anchor brackets (RVB)			6	7	8	9	10

① Plan for additional pinnings of brick courses on-site

Please note: The minimum height of masonry overlying the MOSO® perforated strip is 5 layers NF (≥ 42 cm).



MOSO® perforated strip as approved lintel reinforcement for large openings

Lintel construction $l_w > 2.51 \text{ m} \leq 5.01 \text{ m}$

The combination of

- MOSO® perforated strip type 50 E 420 and
- MOSO® support brackets type EK-W even facilitates lintels over 2.51 m.

Product info

The first off-roll reinforcement.
In stainless steel for universal outdoor use
Without material-intensive edges

Use and application

- The installation of support brackets allows MOSO® perforated strip to be used for clear spans of $> 2.51 \text{ m}$
- The support brackets are anchored in the concrete on the supporting wall shell with type approved fasteners
- Other support variants are possible. Our technical experts are happy to advise you.
- The anchor spacing between the support brackets should be selected in accordance with the planned brickwork height

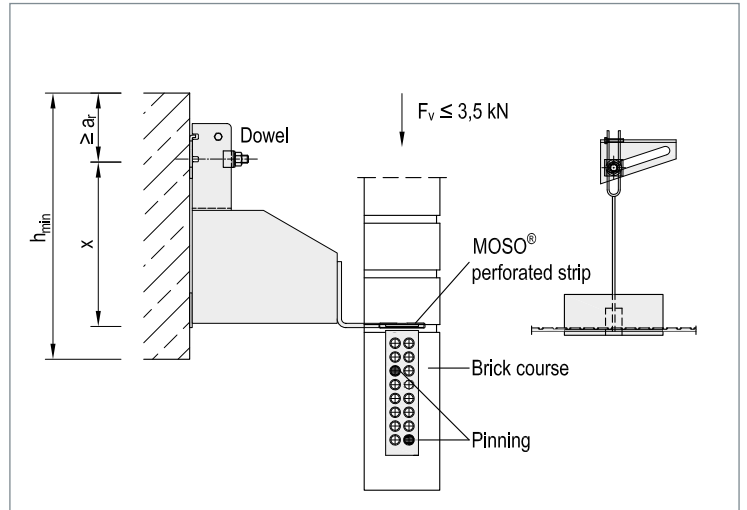

▲ Profile and frontal view of support bracket EK-W with MOSO® perforated strip

- A second layer of MOSO® perforated strip is installed in the second bed joint above the first layer
- Perforated tape stays ensure a secure connection to the lower brick course, and should be installed at intervals of $\leq 25 \text{ cm}$
- Further information is provided in the installation instructions
- We can supply rods in $4 \times 250 \text{ mm}$ for the necessary pinning of the brick course

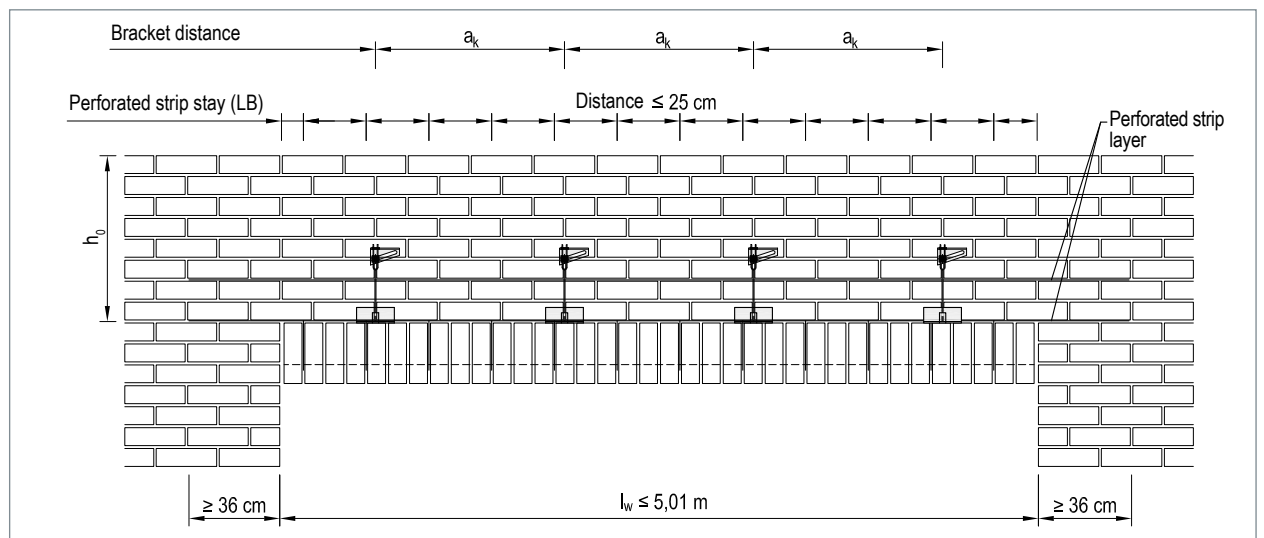

▲ Arrangement of the perforated strip layers and support anchors in the brickwork

Material requirements per lintel ①

Width of opening l_w [m]	2.76	3.01	3.26	3.51	3.76	4.01	4.26	4.51	4.76	5.01
Height of brickwork h [m]	0.42 - 1.60									
Sym. anchor spacing a_k [m]	≤ 0.75									
Number of support brackets EK-W 3.5	3	4	4	4	5	5	5	6	6	6
Cutting length of perforated strip [m] (2x)	3.48	3.73	3.98	4.23	4.48	4.73	4.98	5.23	5.48	5.73
Quantity of perforated tape stays (...)	11	12	13	14	15	16	17	18	19	20

① Plan for additional pinnings of brick courses on-site

Please note: The minimum height of masonry overlying the MOSO® perforated strip is 5 layers NF ($\geq 42 \text{ cm}$).

MOSO® perforated strip as constructive masonry reinforcement



With MOSO® perforated strip type 50 E 235 stainless steel or type 50 galvanised.

Use and application

Crack formation in the brickwork cannot be ruled out, especially for certain masonry components. While they generally have no impact on structural stability, they often constitute a visual and functional defect.

Crack formation can be prevented by inserting the 5 cm wide MOSO® perforated strip into the brickwork. The use of constructive reinforcement as a crack safeguard is not subject to any regulation by the construction authorities or any DIN standard.

Please see the examples on this page for information on the use of the perforated strip.

Use the MOSO® perforated strip type 50 E 235 **stainless steel** for exterior and facing masonry, as well as other areas prone to corrosion.

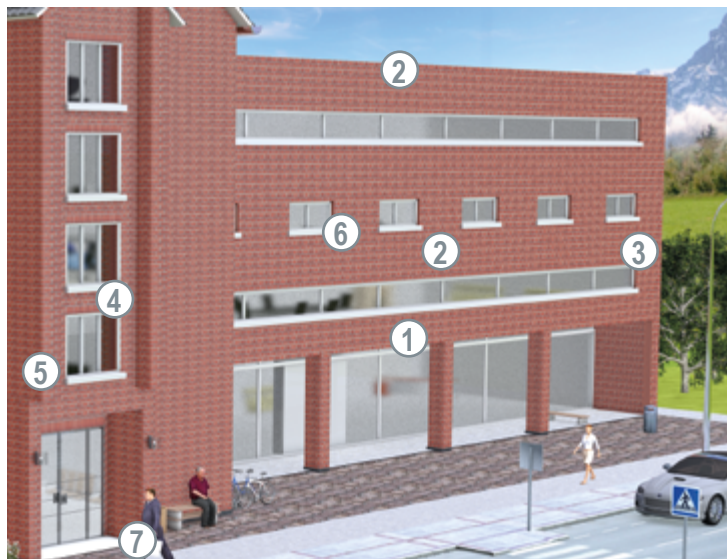

▲ Application examples for the MOSO® house

Application examples

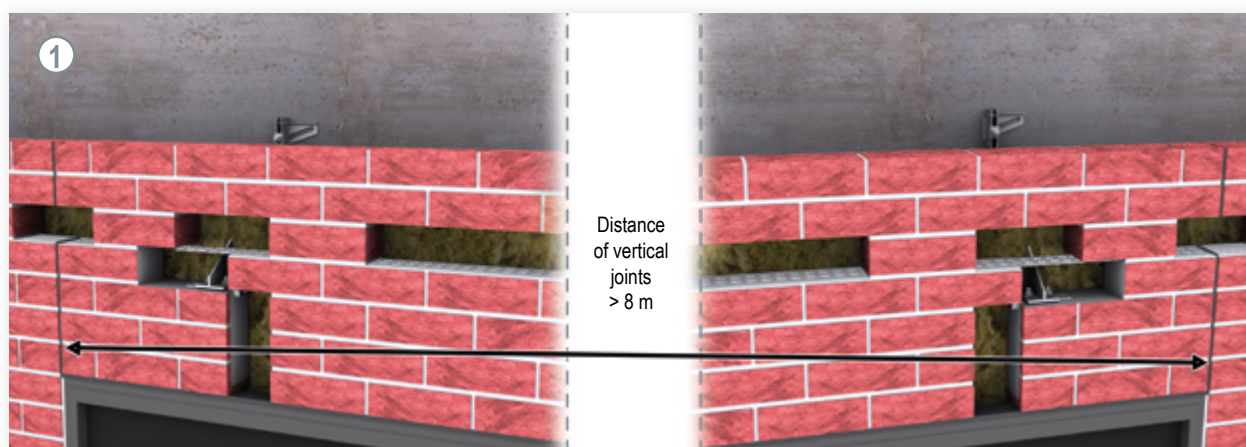

▲ Recommendation for precast bands from 8 m: one layer of perforated strip in the 2nd bearing joint.

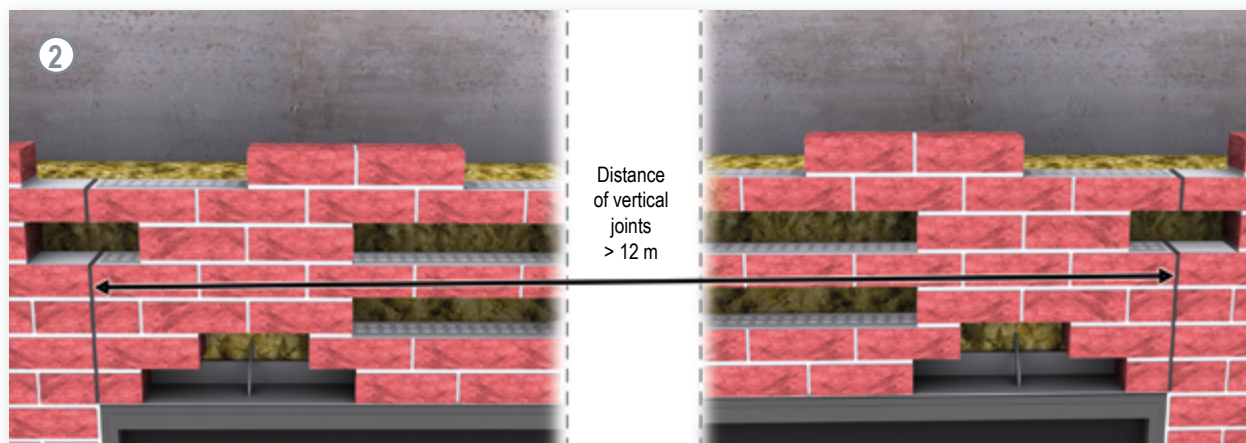

▲ Possibility to increase the maximum vertical joint spacing from 12, through several layers of perforated strip



Installation situations

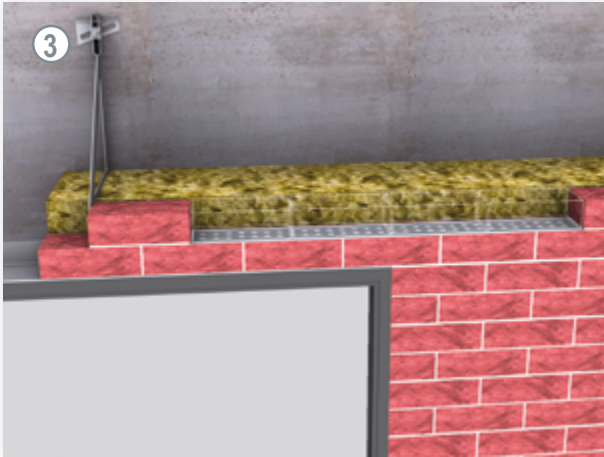

▲ Angle bracket mounted on one side

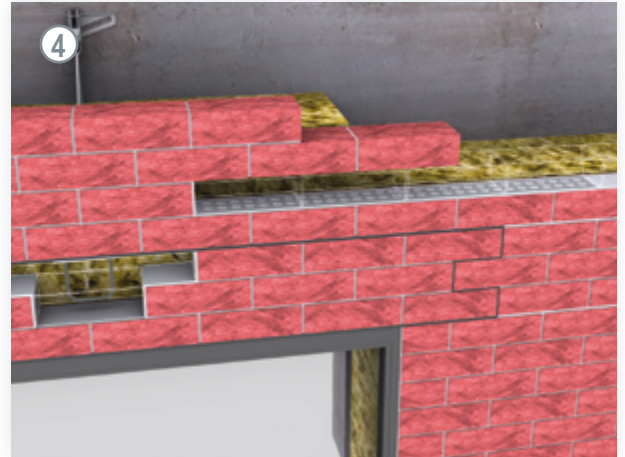

▲ Lintel mounted on one side

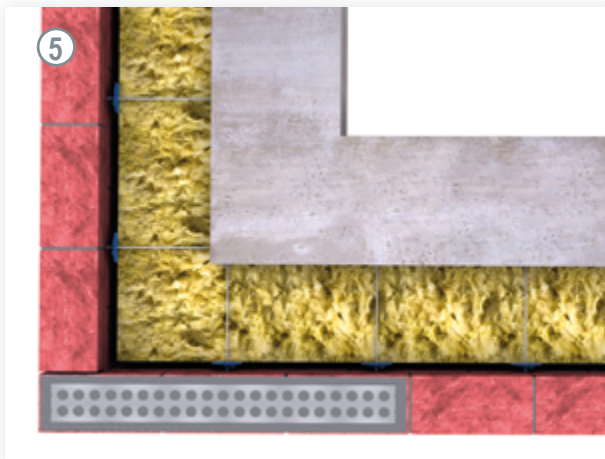

▲ Corners with large tray spacing



▲ Bricklaying differences

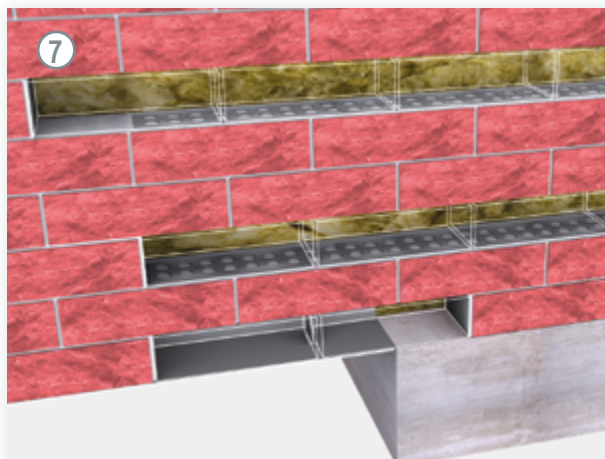

▲ Different foundations / footprints

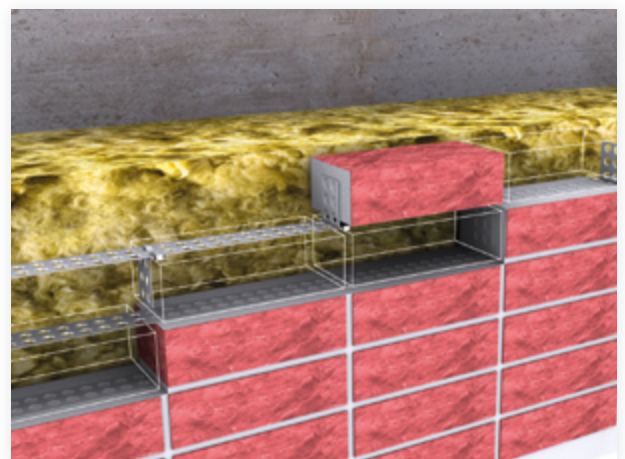

▲ Application for cross joints

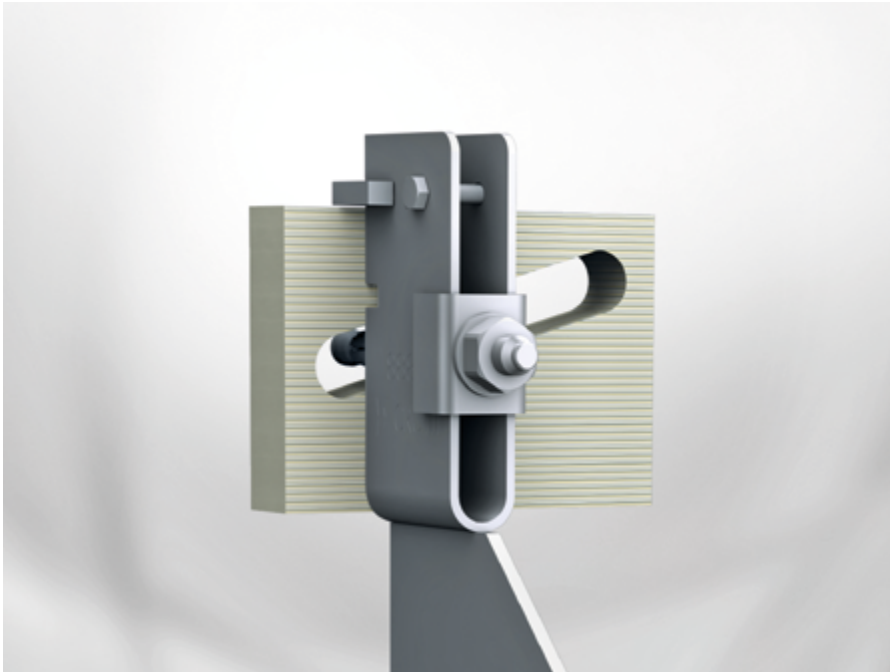

MOSOTherm



MOSOTerm - Thermal separation for facade systems

MOSOTerm is an insulation system for the reduction of thermal thermal bridges in the area of facade fastening systems. This is made possible by a creep- and pressure-resistant glass-fibre reinforced plastic. It has the compressive strength of concrete combined with the thermal conductivity of an aerated concrete block. Through the high strength of the material, it can also be used for other applications, such as the construction of pressure-resistant insulation levels in high-load areas.

Use and application

- Effective reduction of thermal bridges, thanks to the combination of the slim-designed MOSO® façade fixings made of Lean Duplex steel with the load-bearing and stackable MOSOTerm insulation panels made of glass-fibre reinforced plastic.
- in thicknesses of 5 mm and 10 mm
- up to max. 20 mm



▲ EK-U bracket with MOSOTerm separation

Combinations to increase the shell distance

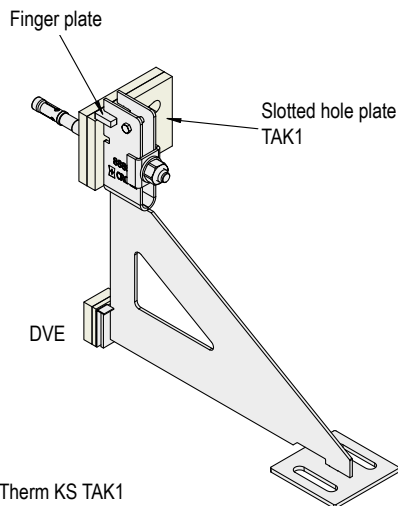

▲ MOSOTerm KS TAK1

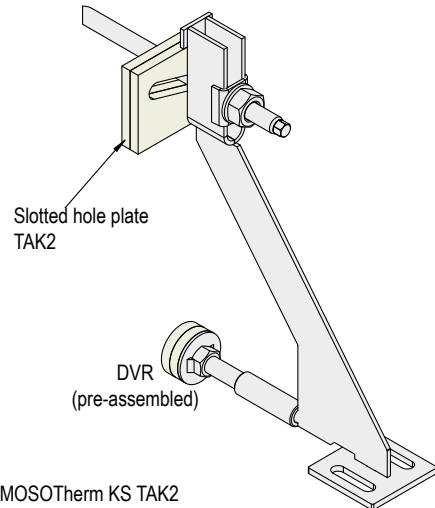

▲ MOSOTerm KS TAK2

TAK1	Slotted hole plate	Pressure point
plus 5 mm	KS12,5 TAK1 MOSOTerm t=10 mm 4461012	DVE5 MOSOTerm 4463044
plus 10 mm	KS12,5 TAK1 MOSOTerm t=15 mm 4461812	DVE10 MOSOTerm 4463045
plus 15 mm	KS12,5 TAK1 MOSOTerm t=20 mm 4461912	DVE15 MOSOTerm 4463046
Finger plate for TAK1-head		4461197

TAK2	Slotted hole plate	Pressure point
plus 5 mm	KS16,5 TAK2 MOSOTerm t=10 mm 4461026	10 mm MOSOTerm Pressure distr. plate
plus 10 mm	KS16,5 TAK2 MOSOTerm t=15 mm 4461826	DVR for M12 or M16, pressure screws
plus 15 mm	KS16,5 TAK2 MOSOTerm t=20 mm 4461926	factory-made pre-assembled

Point thermal transmittance χ



Load stage [kN]	Insulation thickness [mm]	Cantilever length K [mm]	Consol-height X [mm]	Sheet metal thickness t [mm]	Pressure screws [mm]	Point thermal transmittance χ [W/K]				
						FB-U FB-D	FB-US FB-DS optimised	FB-US FB-DS with 5 mm MOSOTerm	FB-US FB-DS with 10 mm MOSOTerm	FB-US FB-DS with 20 mm MOSOTerm
4,0	160	250	175	3	-	0.0148	-	-	-	-
8,0	160	250	250	4	12	0.0173	-	-	-	-
12,0	160	250	300	4	12	0.0183	-	-	-	-
4,0	160	250	150	3	-	-	0.0145	-	-	-
8,0	160	250	260	3	12	-	0.0141	-	-	-
12,0	160	250	330	3	12	-	0.0157	-	-	-
4,0	160	250	150	3	-	-	-	0.0145	-	-
8,0	160	250	260	3	12	-	-	0.0129	-	-
12,0	160	250	330	3	12		-	0.0142	-	-
4,0	160	250	150	3	-		-	-	0.0137	-
8,0	160	250	260	3	12		-	-	0.0121	-
12,0	160	250	330	3	12		-	-	0.0133	-
4,0	160	235	135	3	-		-	-	-	0.0112
8,0	160	235	240	3	12		-	-	-	0.0115
12,0	160	235	305	3	12		-	-	-	0.0129
4,0	200	290	175	4	-	0.0159	-	-	-	-
8,0	200	290	250	4	12	0.0148	-	-	-	-
12,0	200	290	300	5	16	0.0178	-	-	-	-
4,0	200	290	180	3	-	-	0.0127	-	-	-
8,0	200	290	305	3	12	-	0.0126	-	-	-
12,0	200	290	325	4	16	-	0.0155	-	-	-
4,0	200	290	180	3	-	-	-	0.0128	-	-
8,0	200	290	305	3	12	-	-	0.0114	-	-
12,0	200	290	325	4	16		-	0.0143	-	-
4,0	200	290	180	3	-		-	-	0.0122	-
8,0	200	290	305	3	12		-	-	0.0106	-
12,0	200	290	325	4	16		-	-	0.0136	-
4,0	200	275	165	3	-		-	-	-	0.0107
8,0	200	275	290	3	12		-	-	-	0.0100
12,0	200	275	305	4	16		-	-	-	0.0121
4,0	240	330	175	4	-	0.0144	-	-	-	-
8,0	240	330	300	4	12	0.0130	-	-	-	-
12,0	240	330	350	5	16	0.0145	-	-	-	-
4,0	240	330	235	3	-	-	0.0114	-	-	-
8,0	240	330	360	3	12	-	0.0104	-	-	-
12,0	240	330	380	4	16	-	0.0128	-	-	-
4,0	240	330	235	3	-	-	-	0.0115	-	-
8,0	240	330	360	3	12	-	-	0.0097	-	-
12,0	240	330	380	4	16		-	0.0116	-	-
4,0	240	330	235	3	-		-	-	0.0108	-
8,0	240	330	360	3	12		-	-	0.0093	-
12,0	240	330	380	4	16		-	-	0.0111	-
4,0	240	315	205	3	-		-	-	-	0.0100
8,0	240	315	340	3	12		-	-	-	0.0090
12,0	240	315	365	4	16		-	-	-	0.0107

MOSOTerm

Wall structure:

from the inside out

Reinforced concrete

Thermal insulation

Air layer / finger gap

Facing bricks

Heat transfer resistances according to DIN EN ISO 6946: 2018

d = 200 mm

d siehe Tabelle

d = 10 mm

d = 115 mm

$\lambda = 2.300 \text{ W / (mK)}$

$\lambda = 0.035 \text{ W / (mK)}$

$\lambda = 0.067 \text{ W / (mK)}$

$\lambda = 0.960 \text{ W / (mK)}$

Legend:

U_{Ges} resulting thermal transmittance coefficient in a wall with thermal bridges

A_{Wand} wall area

U_{ungest} thermal transmittance coefficient of a normal cross-section in a wall without thermal bridges

n number of brackets

χ (Chi) point thermal transmittance coefficient

$$U_{Ges} = \frac{\Sigma (A_{Wand} \times U_{ungest}) + \Sigma (n \times \chi)}{A_{Wand}}$$



Technical data

Product info

The following values were determined with a panel thickness of 10 mm.

- Material: Glass fibre reinforced plastic (GFK)
- Colour: GFK-nature
- Hollow glass sphere proportion in the resin: 40 Vol.-%
- Density: 1,250 kg/m³ *
- Water absorption: <5,0 % **
- Thermal conductivity value: 0.14 W/mK ***
- Durability: frost and dew resistant ****
- Temperature range: +80°C bis -40°C ****
- Compressive strength: see table 1 ****
- Panel format: 4000/520/10 mm and 4000/520/5 mm (cuts according to customer requirements)

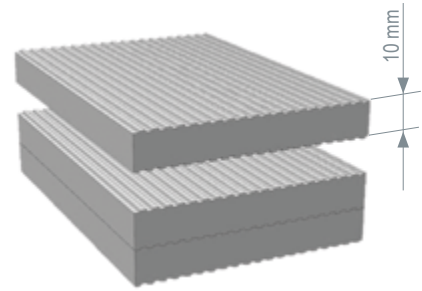

▲ Profiled, stacked insulation boards
Available in board thicknesses of 5 mm and 10 mm

Further use

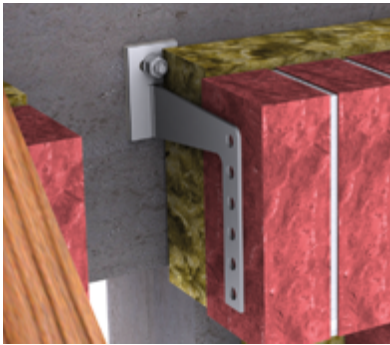

▲ EK-G

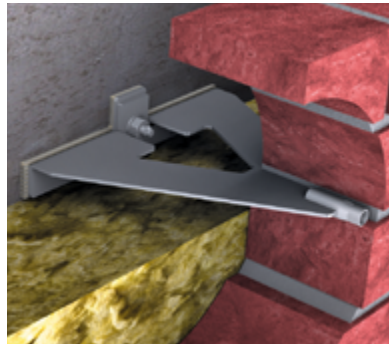

▲ GA-Q



▲ Fascia facing

MOSOTherm for equalising the shell distance

- up to max. 17.5 mm enlargement of the shell distance with TAK1
- from 20 to 50 mm hat profile solution recommended
- > 50 mm fabricate new bracket if necessary

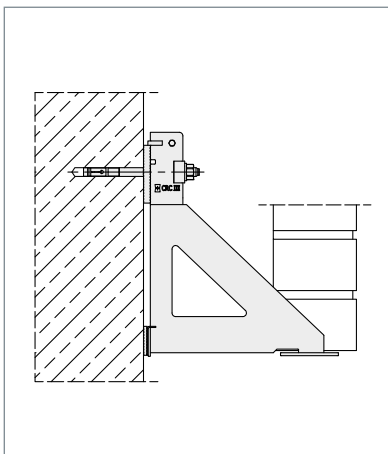

▲ Increase the shell distance (compliant)

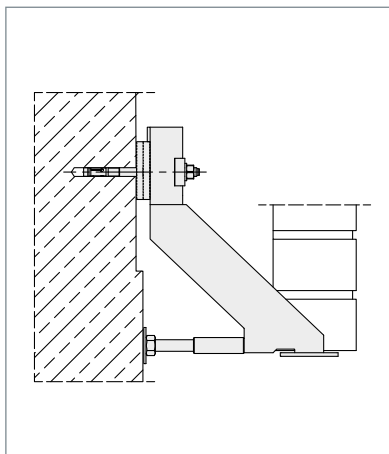

▲ Increase the shell distance (contrarily)

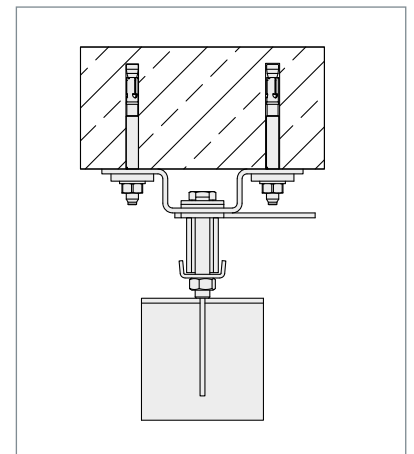

▲ From 20 mm:
Hat profile between carcass and bracket



EK-D

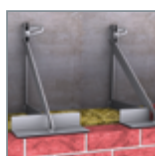

EK-L

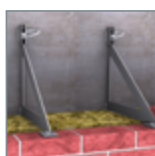

EK-U



EK-G



EK-W



EK-S

MOSO® Single-bracket anchors



Adjustable pressing screw

EK-D

Single-bracket anchors

The MOSO® single-bracket anchor EK-D with adjustable pressure screw for easy installation. The slim design enables reduced heat transmission. The pressure screw makes it easy to compensate for concrete unevenness.

Product info

- Load stages: 4.0 kN - 25.0 kN
- Wall clearances: 20 mm - 370 mm (> on request)
- Height adjustment: ± 25 mm
- Material: stainless steel
corrosion resistance class (CRC) I-V
- Validation: support anchor head acc. to DIBt Approval Z-21.8-1892 type testing or structural calculation

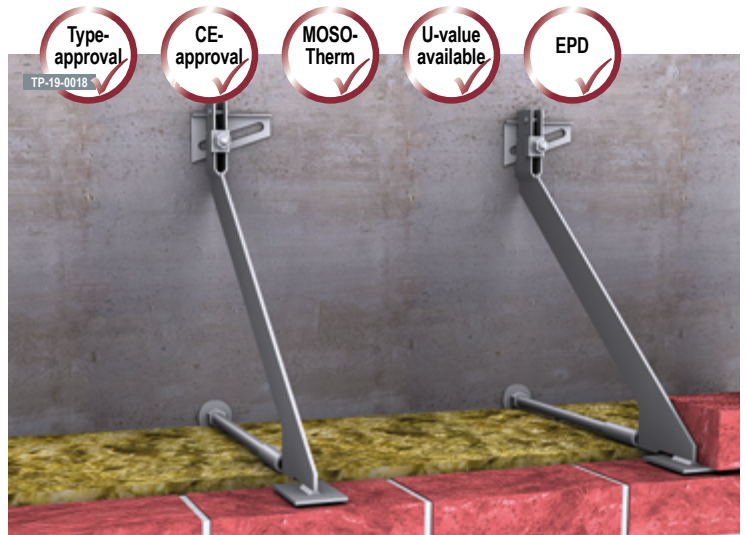

▲ Wall support with MOSO® single-bracket anchor EK-D

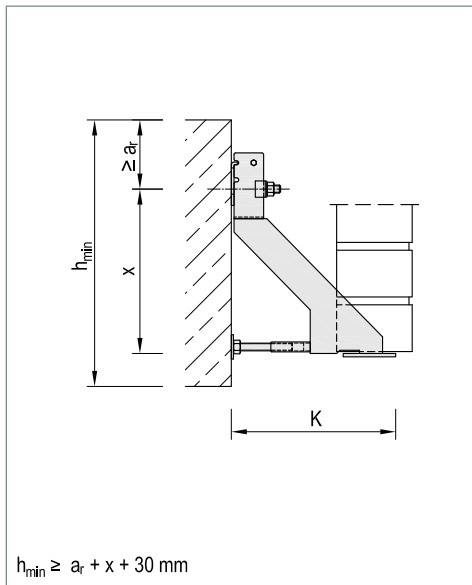

▲ MOSO® single-bracket anchors EK-D

Use and application

- Particularly suited for invisible support of large wall surfaces
- Variable anchor spacing acc. to load and stone format (a_k)
- Install support brackets at intervals of a_k and loosely fit intermediate angle type WA-Z if required
- Support the entire surface of the angle until the mortar is set

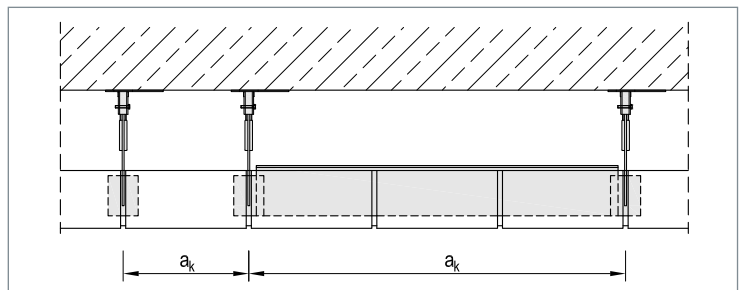

▲ Various anchor spacings can be configured with the intermediate angle type WA-Z

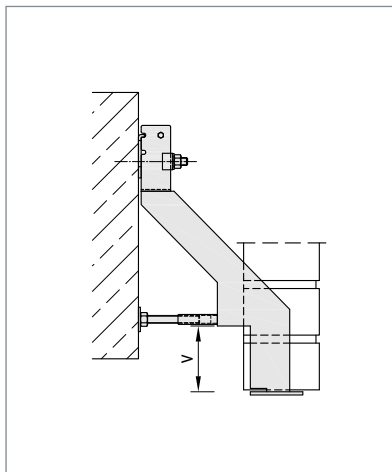

▲ EK-DV

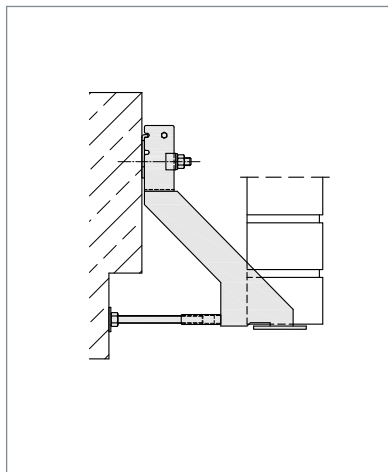

EK-DS for concrete offsets

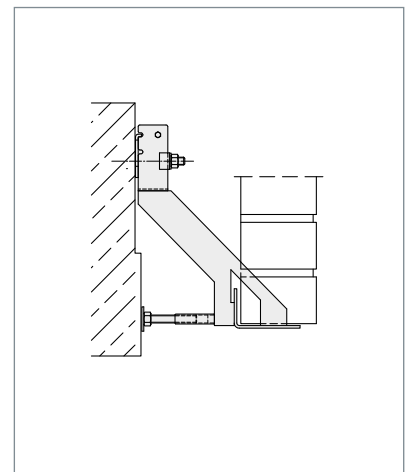

▲ Pressure screw adjustable ± 15 mm

Technical data / measurement chart

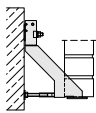
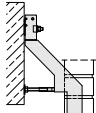

EK-D / EK-DV

Type / Design	Load stage	4.0 kN		8.0 kN		12.0 kN	
	Wall clearance ① [mm]	Cantilever length K [mm]	Bracket height x [mm]	Cantilever length K [mm]	Bracket height x [mm]	Cantilever length K [mm]	Bracket height x [mm]
 EK-D	90 - 110	190	150	190	200	190	250
	100 - 130	210	150	210	200	210	250
	120 - 150	230	175	230	250	230	300
	140 - 170	250	175	250	250	250	300
	160 - 190	270	175	270	250	270	300
 EK-DV	180 - 210	290	175	290	250	290	300
	200 - 230	310	175	310	300	310	350
	220 - 250	330	175	330	300	330	350
	240 - 270	350	200	350	350	350	400
	Larger wall clearances on request						
Support plate [mm]	W / L / T	80 / 60 / 3		80 / 60 / 4		80 / 60 / 5	
Mounting size		M10 / M12		M10 / M12		M12 / M16	
Recommended fixing ②	Dowels fischer	FAZ II 12/60 A4 Edge clearance $a_e \geq 80$ mm		RG M12x200 A4 with RSB 12 Edge clearance $a_e \geq 140$ mm		RG M16x250 A4 with RSB 16 Edge clearance $a_e \geq 140$ mm	
	Dowels Hilti	HST3-R M12x165 90/70 Edge clearance $a_e \geq 80$ mm		HAS-U A4 M12x200 mit HVU2 Edge clearance $a_e \geq 140$ mm		HAS-U A4 M16x260 mit HVU2 Edge clearance $a_e \geq 140$ mm	
	Anchor channels	MBA-CE 38/17 with MHK 38/17 M12x80 Edge clearance $a_e \geq 75$ mm		MBA-CE 50/31 with MHK 50/30 M12x80 Edge clearance $a_e \geq 150$ mm		MBA-CE 52/34 with MHK 50/30 M16x100 Edge clearance $a_e \geq 200$ mm	

① Specifications apply to facing bricks of 115 mm thickness, and a superimposed load of ≤ 2 storeys.

Otherwise, support brackets should be adjusted acc. to DIN EN 1996-2/NA.

② The stated edge clearances are benchmarks. The anchoring should be validated in consideration of the relevant installation situation.

Example order: EK - D - 190 - 8.0



Recommended anchor selection

Superimposed load [m]	Load ③ [kN/m]	Anchor spacing a_k [cm]	Load stage [kN]	Intermediate angle
1.5	3.11	100	4.0	WA-Z-95/50/3-980
2.0	4.14	75	4.0	WA-Z-95/30/3-730
3.0	6.21	50	4.0	WA-Z-95/20/1.5-480
4.5	9.32	75	8.0	WA-Z-95/30/3-730
6.0	12.42	50	8.0	WA-Z-95/20/1.5-480
9.0	18.63	50	12.0	WA-Z-95/20/1.5-480
12.0	24.84	37,5	12.0	WA-Z-95/20/1.5-355

③ Assumption: Facing brick 115 mm thickness with $\gamma = 18$ kN/m³

Tender text

Delivery and professional installation of ... pieces of MOSO® single-bracket anchor type EK-D-210¹⁾-8.0²⁾ with type approved support anchor head for cracked concrete³⁾, incl. dowels.

Alternatively:

Delivery and professional installation of ... m wall bracing with MOSO® single-bracket anchor type EK-D with type approved support anchor head for a brickwork height (insulation and air layer) of ... cm, facing brick thickness of ... cm, incl. dowels for cracked concrete³⁾.

¹⁾ Cantilever length acc. to table

²⁾ Load stage acc. to table

³⁾ Fixing acc. to table

Cross-reference for additional information

Pages	Topic
20 - 21	Edge formation with MOSO® single-bracket anchor EK-W
36 - 37	Intermediate angles with MOSO® angle bearing WA-Z
37	Lintel formation with MOSO® accessories DB
79 - 91	Technical details

Note:

If fixed with hammerhead bolts, the associated support anchor channel should be put out for a separate tender.



Universal anchor

EK-U

Single-bracket anchors

The MOSO® EK-U single bracket anchor is the universal anchor for supporting masonry facing.

Different variants allow the use for almost every purpose in construction.

Product info

- Load stages: 4.0 kN - 25.0 kN
- Wall clearances: 20 mm - 370 mm (> on request)
- Height adjustment: ± 25 mm
- Material: stainless steel
corrosion resistance class (CRC) I-V
- Validation: support anchor head acc. to DIBt Approval Z-21.8-1892
type testing or structural calculation

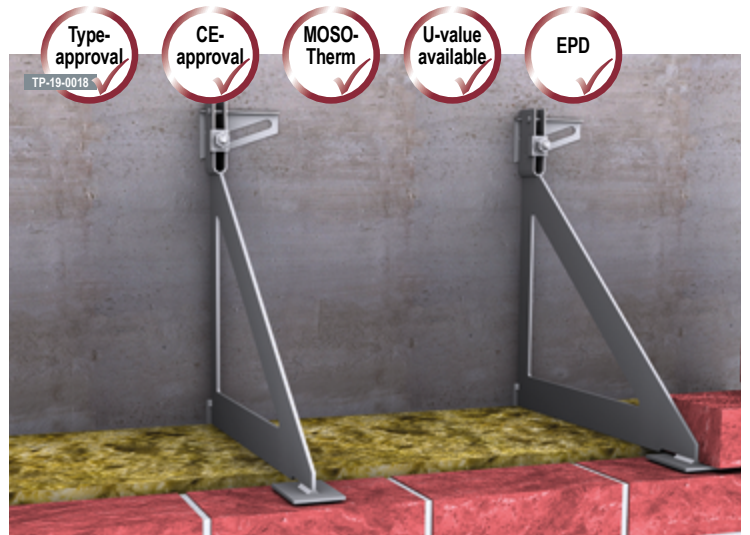

▲ Wall support with MOSO® single-bracket anchor EK-U

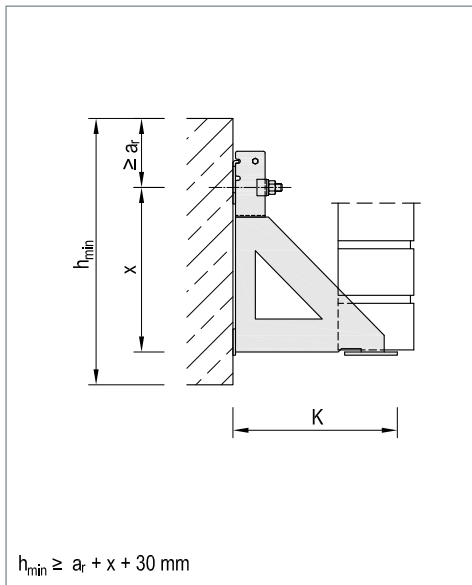

▲ MOSO® single-bracket anchor EK-U

Use and application

- Particularly suited for invisible support of large wall surfaces
- Variable anchor spacing acc. to load and stone format (a_k)
- Install support brackets at intervals of a_k and loosely fit intermediate angle type WA-Z if required
- Support the entire surface of the angle until the mortar is set

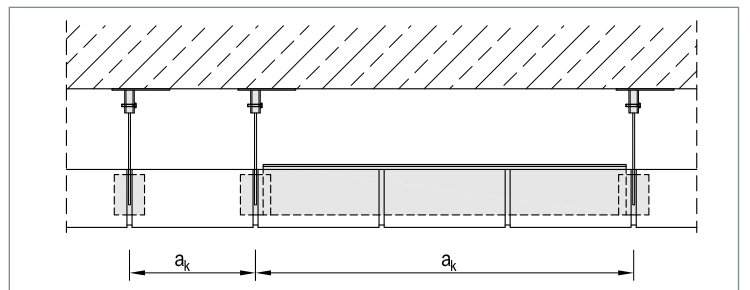

▲ Various anchor spacings can be configured with the intermediate angle type WA-Z

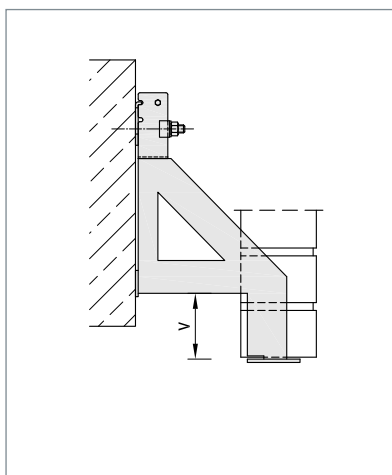

▲ EK-UV with offset

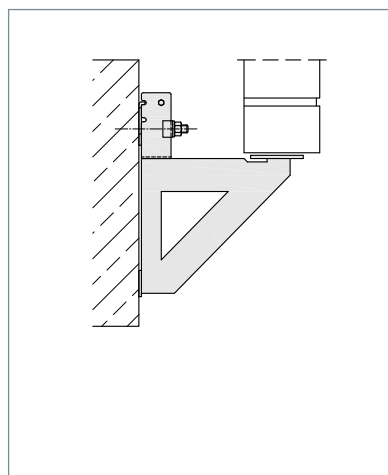

▲ EK-UH

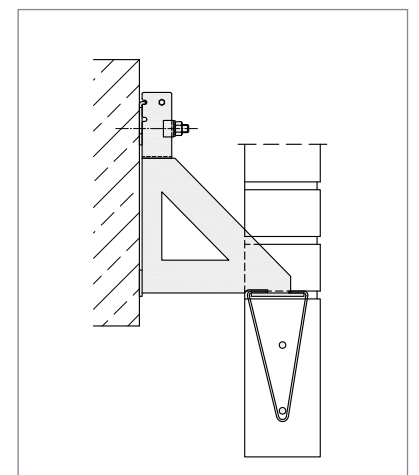

▲ EK-U with wall tie type 2

Technical data / measurement chart

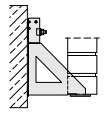
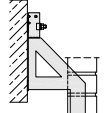
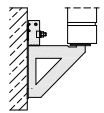

EK-U / EK-UV / EK-UH

Type / Design	Load stage	4.0 kN		8.0 kN		12.0 kN	
	Wall clearance ① [mm]	Cantilever length K [mm]	Bracket height x [mm]	Cantilever length K [mm]	Bracket height x [mm]	Cantilever length K [mm]	Bracket height x [mm]
EK-U 	20 - 50	130	150	130	200	130	250
	40 - 70	150	150	150	200	150	250
	60 - 90	170	150	170	200	170	250
	80 - 110	190	150	190	200	190	250
	100 - 130	210	150	210	200	210	250
EK-UV 	120 - 150	230	175	230	250	230	300
	140 - 170	250	175	250	250	250	300
	160 - 190	270	175	270	250	270	300
	180 - 210	290	175	290	250	290	300
EK-UH 	200 - 230	310	175	310	300	310	350
	220 - 250	330	175	330	300	330	350
	240 - 270	350	200	350	350	350	400
	Larger wall clearances on request						
Support plate [mm]	W / L / T	80 / 60 / 3		80 / 60 / 4		80 / 60 / 5	
Mounting size		M10 / M12		M10 / M12		M12 / M16	
Recommended fixing ②	Dowels fischer	FAZ II 12/60 A4 Edge clearance $a_e \geq 80$ mm		RG M12x200 A4 with RSB 12 Edge clearance $a_e \geq 140$ mm		RG M16x250 A4 with RSB 16 Edge clearance $a_e \geq 140$ mm	
	Dowels Hilti	HST3-R M12x165 90/70 Edge clearance $a_e \geq 80$ mm		HAS-U A4 M12x200 mit HVU2 Edge clearance $a_e \geq 140$ mm		HAS-U A4 M16x260 mit HVU2 Edge clearance $a_e \geq 140$ mm	
	Anchor channels	MBA-CE 38/17 with MHK 38/17 M12x80 Edge clearance $a_e \geq 75$ mm		MBA-CE 50/31 with MHK 50/30 M12x80 Edge clearance $a_e \geq 150$ mm		MBA-CE 52/34 with MHK 50/30 M16x100 Edge clearance $a_e \geq 200$ mm	

Single-bracket anchors

Example order: EK - D - 190 - 8.0

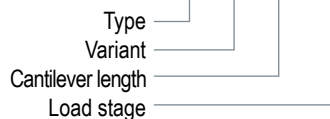

- ① Specifications apply to facing bricks of 115 mm thickness, and a superimposed load of ≤ 2 storeys.
 Otherwise, support brackets should be adjusted acc. to DIN EN 1996-2/NA.
 ② The stated edge clearances are benchmarks. The anchoring should be validated in consideration of the relevant installation situation.

Recommended anchor selection

Superimposed load [m]	Load ③ [kN/m]	Anchor spacing a_k [cm]	Load stage [kN]	Intermediate angle
1.5	3.11	100	4.0	WA-Z-95/50/3-980
2.0	4.14	75	4.0	WA-Z-95/30/3-730
3.0	6.21	50	4.0	WA-Z-95/20/1.5-480
4.5	9.32	75	8.0	WA-Z-95/30/3-730
6.0	12.42	50	8.0	WA-Z-95/20/1.5-480
9.0	18.63	50	12.0	WA-Z-95/20/1.5-480
12.0	24.84	37.5	12.0	WA-Z-95/20/1.5-355

③ Assumption: Facing brick 115 mm thickness with $\gamma = 18$ kN/m³

Tender text

Delivery and professional installation of ... pieces of MOSO® single-bracket anchor type EK-D-210¹⁾-8.0²⁾ with type approved support anchor head for cracked concrete³⁾, incl. dowels.

Alternatively:

Delivery and professional installation of ... m wall bracing with MOSO® single-bracket anchor type EK-D with type approved support anchor head for a brickwork height (insulation and air layer) of ... cm, facing brick thickness of ... cm, incl. dowels for cracked concrete³⁾.

¹⁾ Cantilever length acc. to table

²⁾ Load stage acc. to table

³⁾ Fixing acc. to table

Note:

If fixed with hammerhead bolts, the associated support anchor channel should be put out for a separate tender.

Cross-reference for additional information

Pages	Topic
20 - 21	Edge formation with MOSO® single-bracket anchor EK-W
36 - 37	Intermediate angles with MOSO® angle bearing WA-Z
37	Lintel formation with MOSO® accessories DB
79 - 91	Technical details



The MOSO® EK-W single bracket anchor with angled support is the ideal complement to the MOSO® EK-U single bracket anchor in the expansion joint or edge area.

Due to the free support, a whole block can be placed securely.

Product info

- Load stages: 1.8 kN - 3.5 kN
- Wall clearances: 20 mm - 370 mm (> on request)
- Height adjustment: ± 25 mm
- Material: stainless steel
corrosion resistance class (CRC) I-V
- Validation: support anchor head acc. to DIBt Approval Z-21.8-1892 type testing or structural calculation

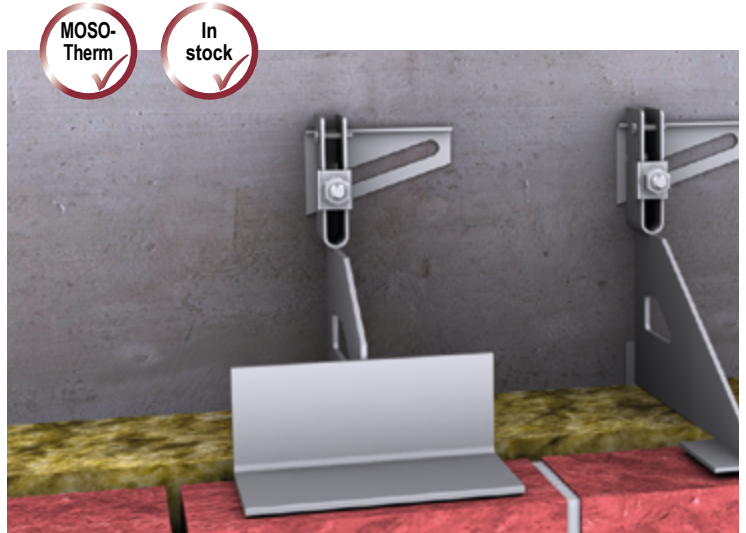

▲ MOSO® single-bracket anchor EK-W as an initial anchor after an expansion joint

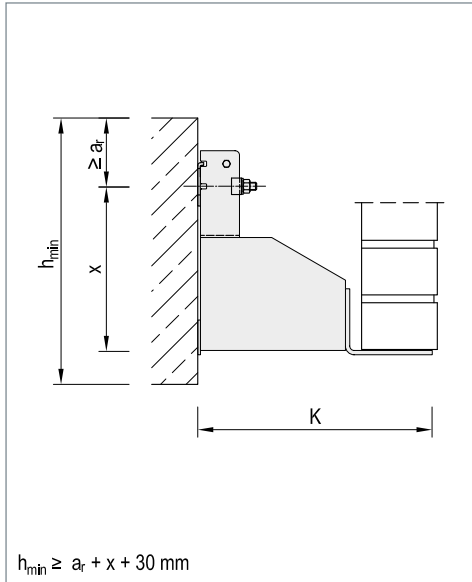

$$h_{\min} \geq a_r + x + 30 \text{ mm}$$

▲ MOSO® single-bracket anchor EK-W

Use and application

- With single-bracket anchor EK-U as initial/end anchor in expansion joint/edge areas
- As a support bracket for lintel reinforcement with MOSO® perforated tape at openings > 2.51 m
- With welded mandrel for bedding precast concrete parts
- Masonry support in pillar areas and for smaller wall surfaces
- Support the entire surface of the angle until the mortar is set

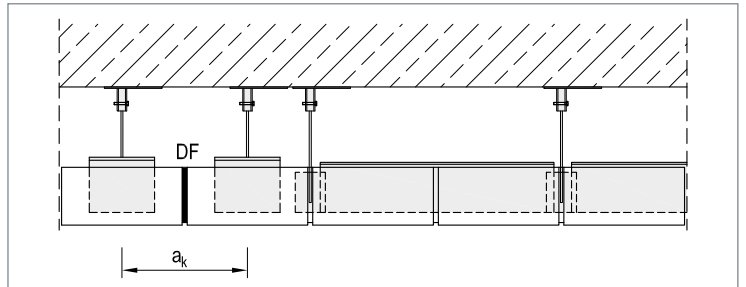

▲ Variant EK-W in combination with EK-U

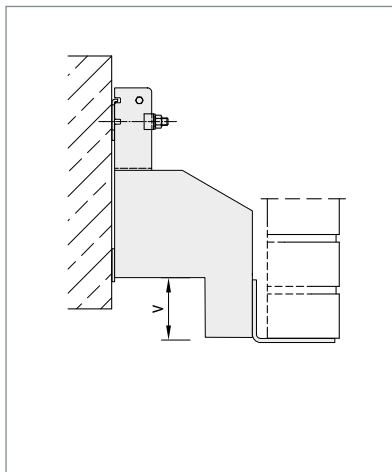

▲ EK-WV with offset

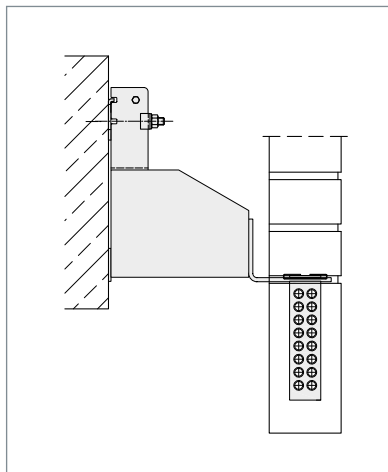

▲ EK-W with perforated strip

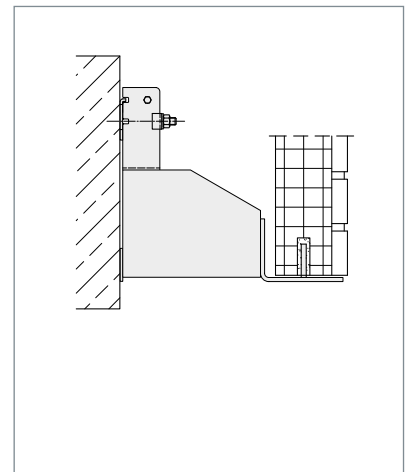

▲ EK-WS with mandrel

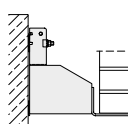
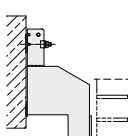

EK-W / EK-WV

Type / Design	Load stage	1.8 kN		3.5 kN		
	Wall clearance ① [mm]	Cantilever length K [mm]	Bracket height x [mm]	Cantilever length K [mm]	Bracket height x [mm]	
EK-W 	20 - 50	130	150	130	150	
	40 - 70	150	150	150	150	
	60 - 90	170	150	170	150	
	80 - 110	190	150	190	150	
	100 - 130	210	150	210	150	
	120 - 150	230	175	230	175	
	140 - 170	250	175	250	175	
EK-WV 	160 - 190	270	175	270	175	
	180 - 210	290	175	290	175	
	200 - 230	310	175	310	175	
	220 - 250	330	175	330	175	
	240 - 270	350	200	350	200	
	Larger wall clearances on request					
	Support angle [mm]	W / H / T...L	100 / 80 / 4...150		100 / 80 / 5...180	
Mounting size		M10 / M12		M10 / M12		
Recommended fixing ②	Dowels fischer	FAZ II 12/60 A4 Edge clearance $a_r \geq 80$ mm		FAZ II 12/60 A4 Edge clearance $a_r \geq 80$ mm		
	Dowels Hilti	HST3-R M12x165 90/70 Edge clearance $a_r \geq 80$ mm		HST3-R M12x165 90/70 Edge clearance $a_r \geq 80$ mm		
	Anchor channels	MBA-CE 38/17 with MHK 38/17 M12x80 Edge clearance $a_r \geq 75$ mm		MBA-CE 38/17 with MHK 38/17 M12x80 Edge clearance $a_r \geq 75$ mm		

Example order: EK - W - 210 - 1.8

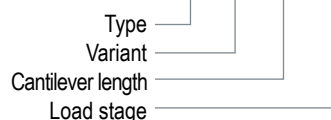

- ① Specifications apply to facing bricks of 115 mm thickness, and a superimposed load of ≤ 2 storeys.
 Otherwise, support brackets should be adjusted acc. to DIN EN 1996-2/NA.
 ② The stated edge clearances are benchmarks. The anchoring should be validated in consideration of the relevant installation situation.

Recommended anchor selection

Superimposed load [m]	Load ③ [kN/m]	Anchor spacing a_k [cm]	Load stage [kN]
1.50	3.11	25	1.8
2.00	4.14	25	1.8
3.00	6.21	25	1.8
4.50	9.32	25	3.5
6.00	12.42	25	3.5

③ Assumption: Facing brick 115 mm thickness with $\gamma = 18$ kN/m³

Tender text

Delivery and professional installation of ... pieces of MOSO® single-bracket anchor type EK-W-210¹⁾-1.8²⁾ with type approved support anchor head for cracked concrete³⁾, incl. dowels.

Alternatively:

Delivery and professional installation of ... pieces of wall bracing with MOSO® single-bracket anchor type EK-Wall support with type approved support anchor head for a brickwork height (insulation and air layer) of ... cm, facing brick thickness of ... cm, incl. dowels for cracked concrete³⁾.

¹⁾ Cantilever length acc. to table

²⁾ Load stage acc. to table

³⁾ Fixing acc. to table

Cross-reference for additional information

Pages	Topic
7	Lintel support with MOSO® perforated strip
16 - 19	Wall support with MOSO® single-bracket anchor EK-U / EK-D
79 - 91	Technical details

Note:

If fixed with hammerhead bolts, the associated support anchor channel should be put out for a separate tender.



With longer support

EK-L

The MOSO® EK-L single bracket anchor with its longer support is an interesting alternative to the standard solution, as the flat support angle makes installation more convenient.

Product info

- Load stages: 4.0 kN - 25.0 kN
- Wall clearances: 20 mm - 370 mm (> on request)
- Height adjustment: ± 25 mm
- Material: stainless steel
corrosion resistance class (CRC) I-V
- Validation: support anchor head acc. to DIBt Approval Z-21.8-1892
type testing or structural calculation

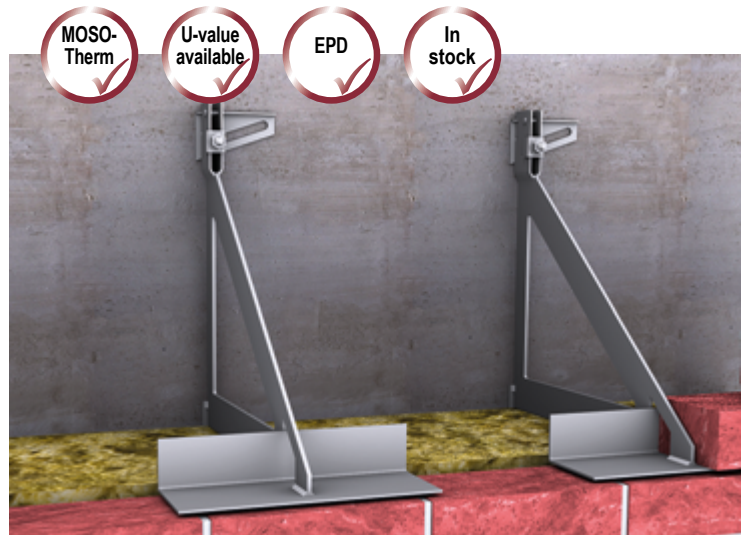

▲ Wall support with MOSO® single-bracket anchor EK-L

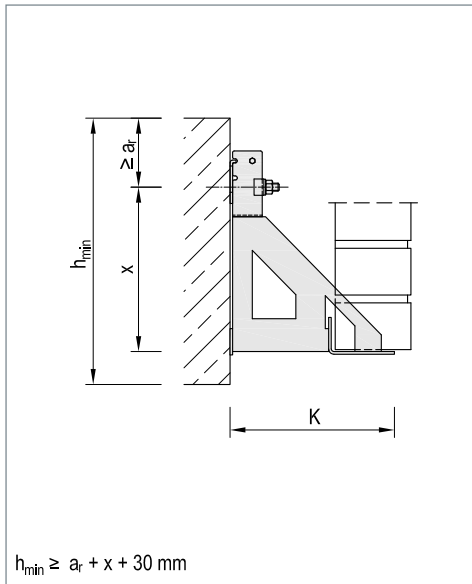

▲ MOSO® single-bracket anchor EK-L

Use and application

- Particularly suited for invisible support of wall surfaces
- Can also be used near corners and edges if the gap between walls is small
- Fixed anchor spacing a_k of 2 bricks ($\leq 50 \text{ cm}$)
- The entire surface of the angle should be supported until the mortar is set

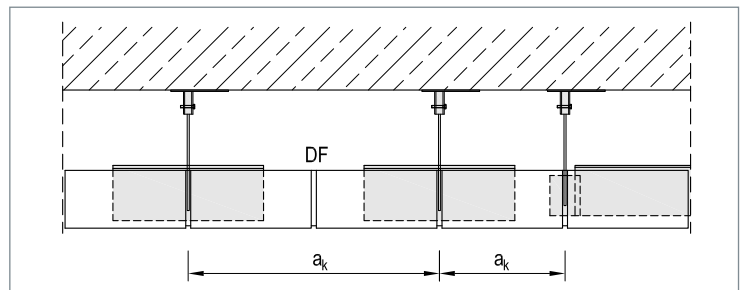

▲ Each support bracket supports 2 bricks

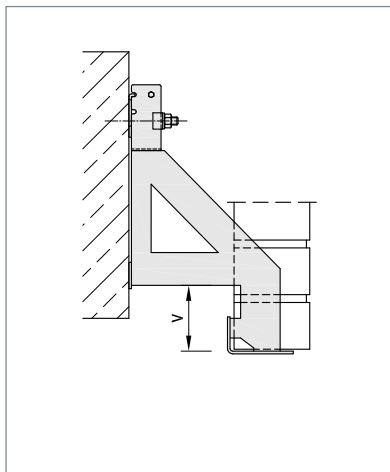

▲ EK-LV with offset

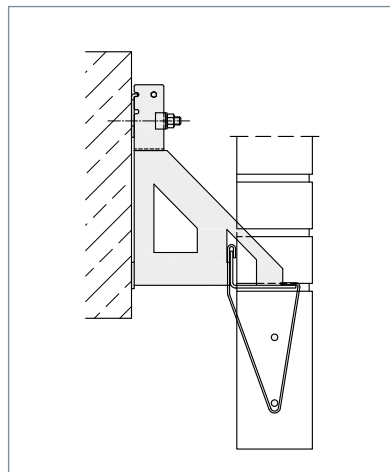

▲ EK-L with wire binder type 1

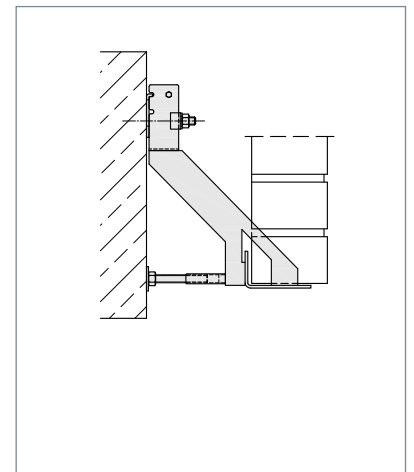

▲ EK-LD

Technical data / measurement chart

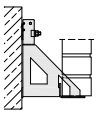
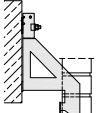

EK-L / EK-LV

Type / Design	Load stage	4.0 kN		8.0 kN		12.0 kN		
	Wall clearance ① [mm]	Cantilever length K [mm]	Bracket height x [mm]	Cantilever length K [mm]	Bracket height x [mm]	Cantilever length K [mm]	Bracket height x [mm]	
 EK-L	20 - 50	130	150	130	200	130	250	
	40 - 70	150	150	150	200	150	250	
	60 - 90	170	150	170	200	170	250	
	80 - 110	190	150	190	200	190	250	
	100 - 130	210	150	210	200	210	250	
	120 - 150	230	175	230	250	230	300	
 EK-LV	140 - 170	250	175	250	250	250	300	
	160 - 190	270	175	270	250	270	300	
	180 - 210	290	175	290	250	290	300	
	200 - 230	310	175	310	300	310	350	
	220 - 250	330	175	330	300	330	350	
	240 - 270	350	200	350	350	350	400	
	Larger wall clearances on request							
	Support angle [mm]	W / H / T...L	100 / 42 / 3...300		100 / 56 / 3...300		100 / 58 / 4...300	
Mounting size		M10 / M12		M10 / M12		M12 / M16		
Recommended fixing ②	Dowels	FAZ II 12/60 A4 Edge clearance $a_e \geq 80$ mm		RG M12x200 A4 with RSB 12 Edge clearance $a_e \geq 140$ mm		RG M16x250 A4 with RSB 16 Edge clearance $a_e \geq 140$ mm		
	Dowels Hilti	HST3-R M12x165 90/70 Edge clearance $a_e \geq 80$ mm		HAS-U A4 M12x200 mit HVU2 Edge clearance $a_e \geq 140$ mm		HAS-U A4 M16x260 mit HVU2 Edge clearance $a_e \geq 140$ mm		
	Anchor channels	MBA-CE 38/17 with MHK 38/17 M12x80 Edge clearance $a_e \geq 75$ mm		MBA-CE 50/31 with MHK 50/30 M12x80 Edge clearance $a_e \geq 150$ mm		MBA-CE 52/34 with MHK 50/30 M16x100 Edge clearance $a_e \geq 200$ mm		

① Specifications apply to facing bricks of 115 mm thickness, and a superimposed load of ≤ 2 storeys.

Otherwise, support brackets should be adjusted acc. to DIN EN 1996-2/NA.

② The stated edge clearances are benchmarks. The anchoring should be validated in consideration of the relevant installation situation.

Example order: EK - L - 170 - 4.0

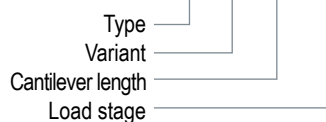

Recommended anchor selection

Superimposed load [m]	Load ③ [kN/m]	Anchor spacing a_k [cm]	Load stage [kN]
1.50	3.11	50	4.0
2.00	4.14	50	4.0
3.00	6.21	50	4.0
4.50	9.32	50	8.0
6.00	12.42	50	8.0
9.00	18.63	50	12.0

③ Assumption: Facing brick 115 mm thickness with $\gamma = 18$ kN/m³

Tender text

Delivery and professional installation of ... pieces of MOSO® single-bracket anchor type EK-L-210¹⁾-4.0²⁾ with type approved support anchor head for cracked concrete³⁾, incl. dowels.

Alternatively:

Delivery and professional installation of ... m wall bracing with MOSO® single-bracket anchor type EK-L with type approved support anchor head for a brickwork height of (insulation and air layer) of ... cm, facing brick thickness of ... cm, incl. dowels for cracked concrete³⁾.

¹⁾ Cantilever length acc. to table

²⁾ Load stage acc. to table

³⁾ Fixing acc. to table

Note:

If fixed with hammerhead bolts, the associated support anchor channel should be put out for a separate tender.

Cross-reference for additional information

Pages	Topic
37	Lintel formation with MOSO® accessories DB
79 - 91	Technical details



For grenadier lintels with low brickwork height

EK-G

Single-bracket anchors

The MOSO® EK-G single bracket anchor is the economical solution for grenadier lintels with low brickwork.

The EK-GE variant can also be used to create corner lintels.

Product info

- Load stages: 1.0 kN
- Wall clearances: 20 mm - 200 mm (> on request)
- Material: stainless steel
corrosion resistance class (CRC) I-V
- Validation: structural calculation

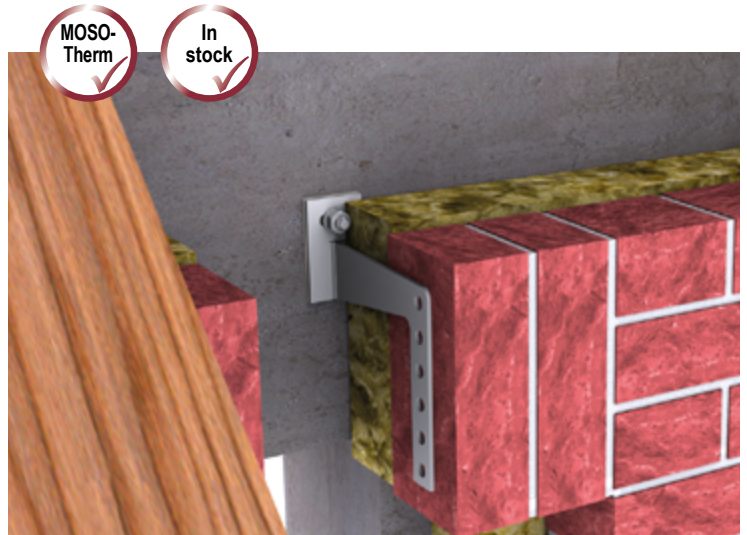

▲ Lintel support with MOSO® single-bracket anchor EK-G

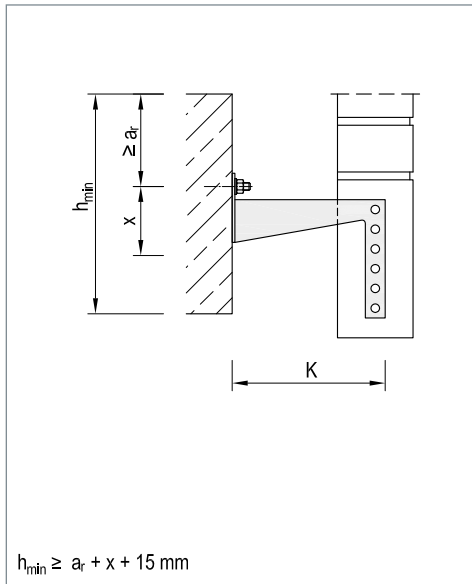

▲ MOSO® single-bracket anchor EK-G

Use and application

- For invisible lintel support with a low brickwork height
- Can also be used near corners and edges
- When using facing bricks with poor mortar bonding, additional pinning of the bricks is recommended
- Single-bracket anchor selection is not dependent on the length of the lintel
- Install single-bracket anchors at intervals of $a_k \leq 25 \text{ cm}$

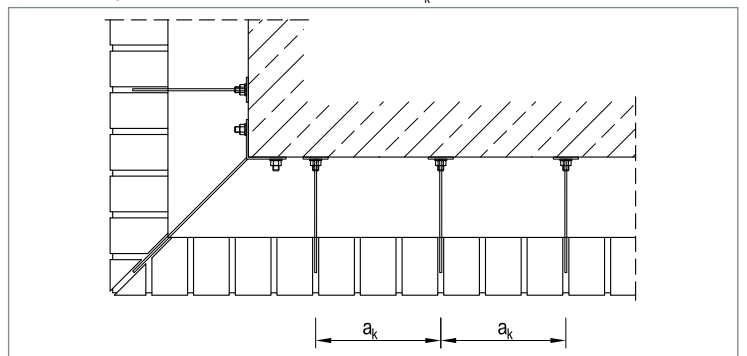

▲ Corner lintel with types EK-G and EK-GE

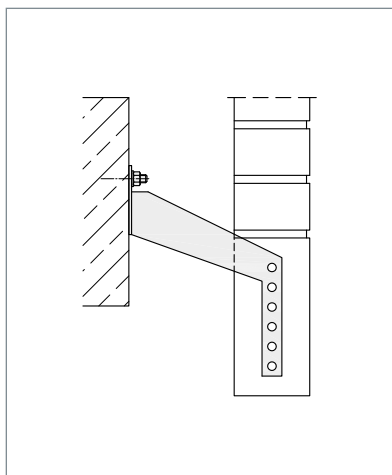

▲ EK-GV with offset

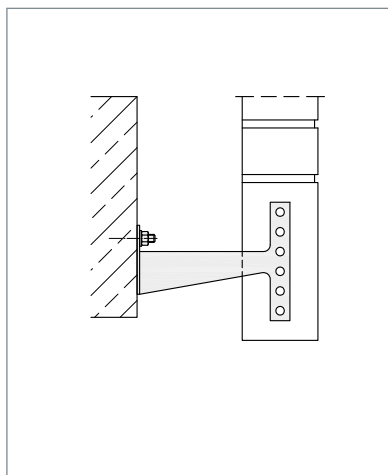

▲ EK-GE in corner areas

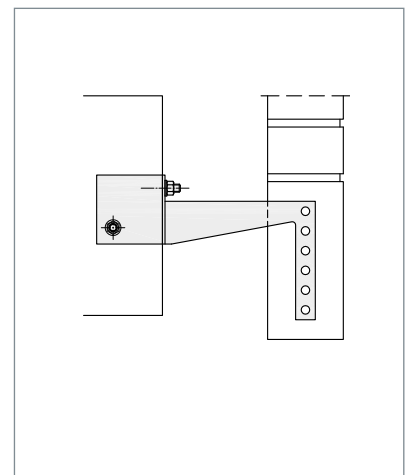

▲ Type EK-GH with raised web plate

Technical data / measurement chart



EK-G / EK-GV

Type / Design	Load stage	1.0 kN	
	Wall clearance ① [mm]	Cantilever length K [mm]	Bracket height x [mm]
 EK-G	10 - 30	95	55
	30 - 50	115	55
	50 - 70	135	65
	70 - 90	155	75
	90 - 110	175	85
 EK-GV	110 - 130	195	95
	130 - 150	215	105
	150 - 170	235	125
	170 - 190	255	135
	190 - 200	275	145
Larger wall clearances on request			
Bond length [mm] ③		180	
Mounting size		M10	
Recommended fixing ②	Dowels	SXS 10x60 F US A4 Edge clearance $a_e \geq 80$ mm	
	Anchor channels	MBA-CE 28/15 with MHK 28/15 M10x30 Edge clearance $a_e \geq 50$ mm	

① Specifications apply to facing bricks of 115 mm thickness

② The stated edge clearances are benchmarks. The anchoring should be validated in consideration of the relevant installation situation.

③ Length of perforated strip

Example order: EK - G - 175 - 1.0

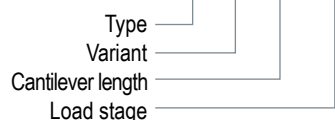

Recommended anchor selection

Superimposed load [m]	Load ③ [kN/m]	Anchor spacing a_k [cm]	Load stage [kN]
1.50	3.11	25.0	1.0

③ Assumption: Facing brick 115 mm thickness with $\gamma' = 18$ kN/m³

Tender text

Delivery and professional installation of ... pieces of MOSO® single-bracket anchor type EK-G-155¹-1.0², incl. fixing.

Alternatively:

Delivery and professional installation of ... m wall bracing with MOSO® single-bracket anchor type EK-G for a brickwork height (insulation and air layer) of ... cm, facing brick thickness of ... cm, incl. fixing.

¹ Cantilever length acc. to table

² Load stage acc. to table

Cross-reference for additional information

Pages	Topic
79 - 91	Technical details



Special brackets

EK-S

The MOSO® EK-S single bracket anchors in special design are calculated individually by our engineering office to ensure optimum solutions even in difficult conditions.

Product info

- Load stages: as required
- Wall clearances: as required
- Material: stainless steel
corrosion resistance class (CRC) I-V
- Validation: structural calculation

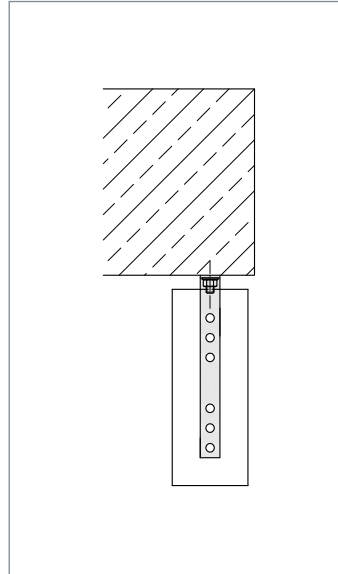

▲ For suspended brick course

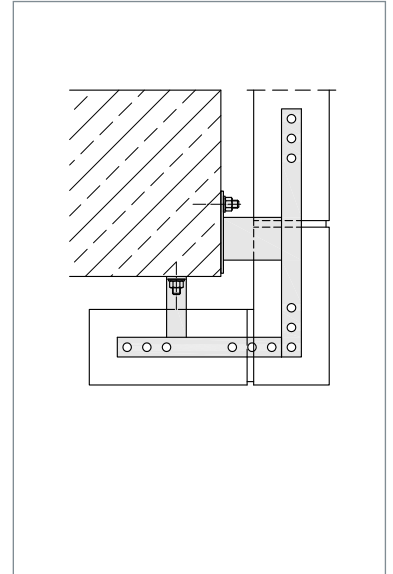

▲ For L-shaped lintel construction

Use and application

- Dimensioning of special support brackets acc. to structural and constructional requirements

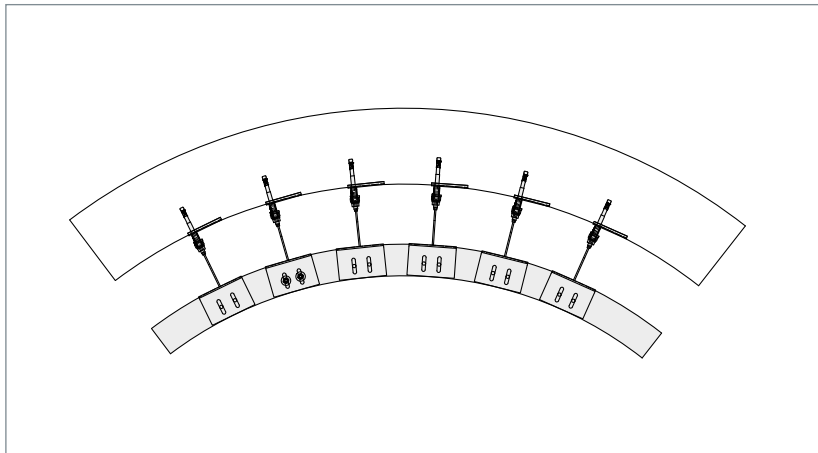

▲ Round interception areas by means of individual brackets and laser-cut flats corresponding to the radius as stone supports

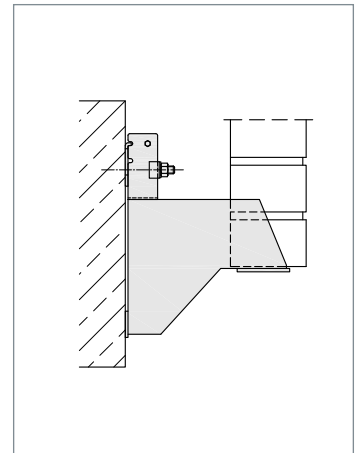

▲ With raised supporting plate

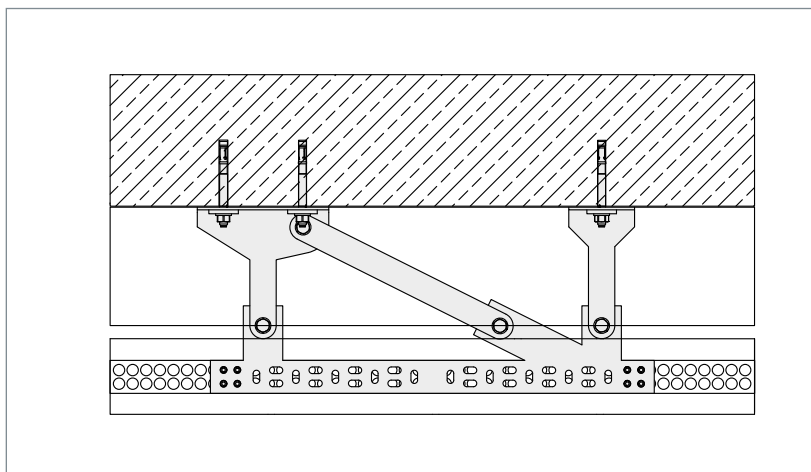

▲ EK-EB for earthquake protection, combined with MOSO® perforated tape

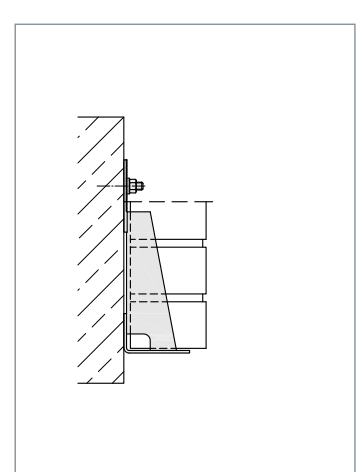

▲ For small loads



WK-D

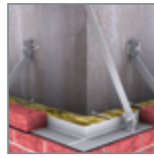

WK-Z

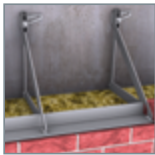

WK-N



WK-S

MOSO® Angle support brackets



Adjustable pressure screw

WK-D

Angle support brackets

The MOSO® angle support bracket WK-D with its adjustable pressure screw is the perfect solution for bracing with continuous angle rail. The pressure screw makes it easy to compensate for concrete unevenness.

Product info

- Load stages: 4.0 kN - 25.0 kN
- Wall clearances: 20 mm - 370 mm (> on request)
- Height adjustment: ± 25 mm
- Material: stainless steel
corrosion resistance class (CRC) I-V
- Validation: support anchor head acc. to DIBt Approval Z-21.8-1892 type testing or structural calculation

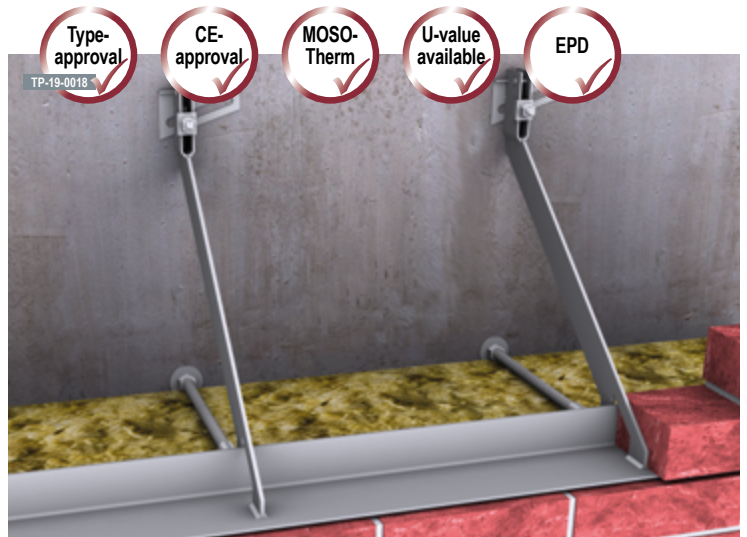

▲ Wall support with MOSO® angle-bracket anchor WK-D

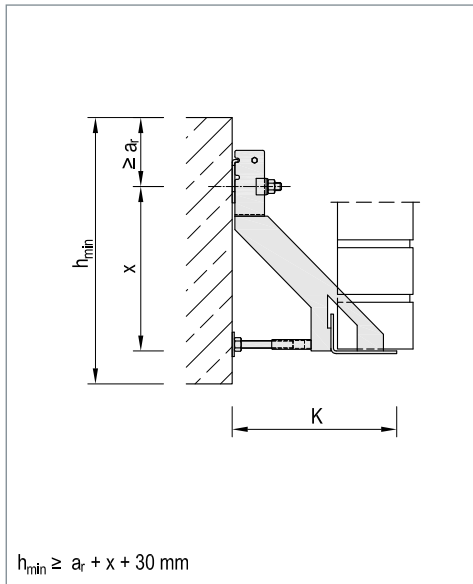

▲ MOSO® angle-bracket anchor WK-D

Use and application

- Particularly suitable for compensating concrete offsets
- Can also be used in corner and edge areas
- Support the entire surface of the angle until the mortar is set

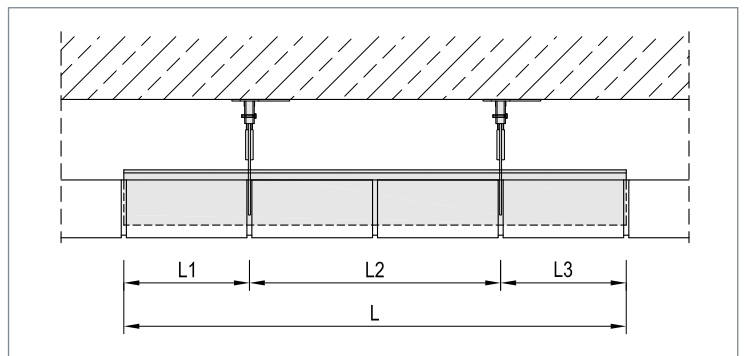

▲ Length dimensioning acc. to local conditions

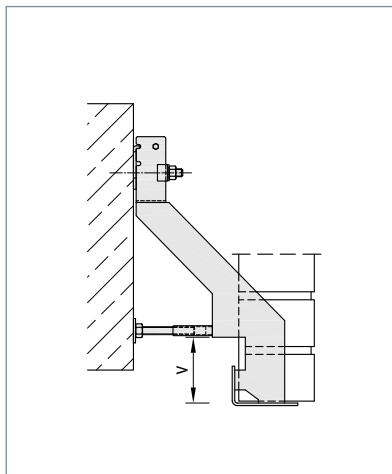

▲ WK-CV with offset

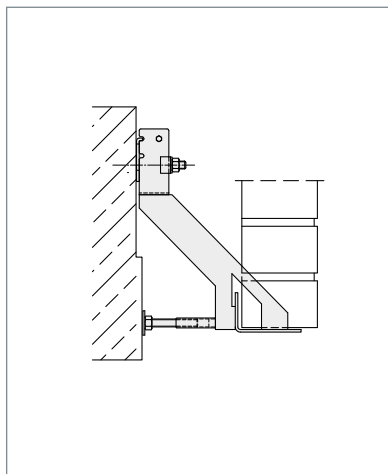

▲ Pressure screw adjustable ± 15 mm

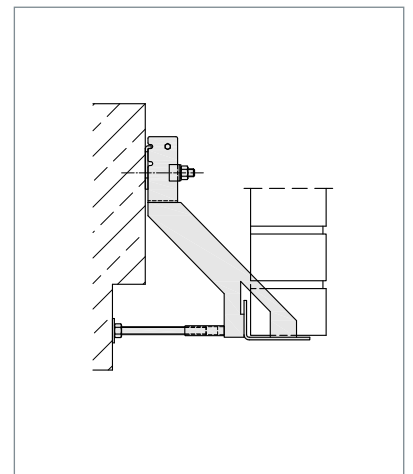

▲ WK-DS with longer pressure screw

Technical data / measurement chart



WK-D / WK-DV

Type / Design	Load stage	4.0 kN		8.0 kN		12.0 kN	
	Wall clearance ① [mm]	Cantilever length K [mm]	Bracket height x [mm]	Cantilever length K [mm]	Bracket height x [mm]	Cantilever length K [mm]	Bracket height x [mm]
WK-D 	90 - 110	190	150	190	200	190	250
	100 - 130	210	150	210	200	210	250
	120 - 150	230	175	230	250	230	300
	140 - 170	250	175	250	250	250	300
	160 - 190	270	175	270	250	270	300
WK-DV 	180 - 210	290	175	290	250	290	300
	200 - 230	310	175	310	300	310	350
	220 - 250	330	175	330	300	330	350
	240 - 270	350	200	350	350	350	400
	Larger wall clearances on request						
Angle width [mm]	B	100		100		100	
Angle length [mm]	L	up to 4000		up to 4000		up to 4000	
Mounting size		M10 / M12		M10 / M12		M12 / M16	
Recommended fixing ②	Dowels fischer	FAZ II 12/60 A4 Edge clearance $a_f \geq 80$ mm		RG M12x200 A4 with RSB 12 Edge clearance $a_f \geq 140$ mm		RG M16x250 A4 with RSB 16 Edge clearance $a_f \geq 140$ mm	
	Dowels Hilti	HST3-R M12x165 90/70 Edge clearance $a_f \geq 80$ mm		HAS-U A4 M12x200 mit HVU2 Edge clearance $a_f \geq 140$ mm		HAS-U A4 M16x260 mit HVU2 Edge clearance $a_f \geq 140$ mm	
	Anchor channels	MBA-CE 38/17 with MHK 38/17 M12x80 Edge clearance $a_f \geq 75$ mm		MBA-CE 50/31 with MHK 50/30 M12x80 Edge clearance $a_f \geq 150$ mm		MBA-CE 52/34 with MHK 50/30 M16x100 Edge clearance $a_f \geq 200$ mm	

Example order: WK - D - 230 - 8.0 - 1000 - 2R

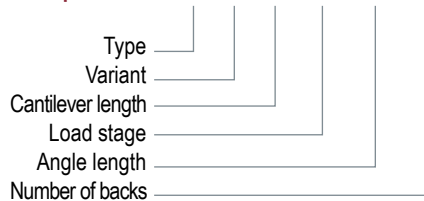

- ① Specifications apply to facing bricks of 115 mm thickness, and a superimposed load of ≤ 2 storeys. Otherwise, support brackets should be adjusted acc. to DIN EN 1996-2/NA.
 ② The stated edge clearances are benchmarks. The anchoring should be validated in consideration of the relevant installation situation.

Recommended anchor selection

Superimposed load [m]	Load ③ [kN/m]	Angle length / No. Bracket backs	Load stage [kN]	Distribution L1 / L2 / L3
1.5	3.11	2000 mm / 2R	4.0	500 / 1000 / 500
2.0	4.14	1880 mm / 2R	4.0	400 / 1080 / 400
3.0	6.21	1250 mm / 2R	4.0	250 / 750 / 250
4.5	9.32	1630 mm / 2R	8.0	250 / 750 / 250
6.0	12.42	1250 mm / 2R	8.0	250 / 750 / 250
9.0	18.63	1250 mm / 2R	12.0	250 / 750 / 250
12.0	24.84	880 mm / 2R	12.0	190 / 500 / 190

③ Assumption: Facing brick 115 mm thickness with $\gamma' = 18$ kN/m³

Cross-reference for additional information

Pages	Topic
32	Corner support with type WK-Z
37	Lintel construction with DB / HB
70	Corners and edging
70	Abutment for suspended facing
79 - 91	Technical details

Tender text

Delivery and professional installation of ... pieces of MOSO® angle support bracket type WK-D-210¹⁾-8.0²⁾-1000³⁾-2R⁴⁾ with type approved support anchor head, incl. dowels for cracked concrete⁵⁾.

Alternatively:

Delivery and professional installation of ... m wall bracing with MOSO® angle support bracket type WK-ZD with type approved support anchor head for a brickwork height (insulation and air layer) of ... cm, facing brick thickness of ... cm, incl. anchors for cracked concrete⁵⁾.

¹⁾ Cantilever length acc. to table

²⁾ Load stage acc. to table

³⁾ Length of element

⁴⁾ Number of backs

⁵⁾ Fixing acc. to table

Note:

If fixed with hammerhead bolts, the associated support anchor channel should be put out for a separate tender.



Standard angle support bracket

WK-N

Angle support brackets

The MOSO® angle support bracket WK-N is the standard anchor for bracing with continuous angle rail. With this anchor, complete bracing can also be realised in corner areas with only one type of bracket.

Product info

- Load stages: 4.0 kN - 25.0 kN
- Wall clearances: 20 mm - 370 mm (> on request)
- Height adjustment: ± 25 mm
- Material: stainless steel
corrosion resistance class (CRC) I-V
- Validation: support anchor head acc. to DIBt Approval Z-21.8-1892
type testing or structural calculation

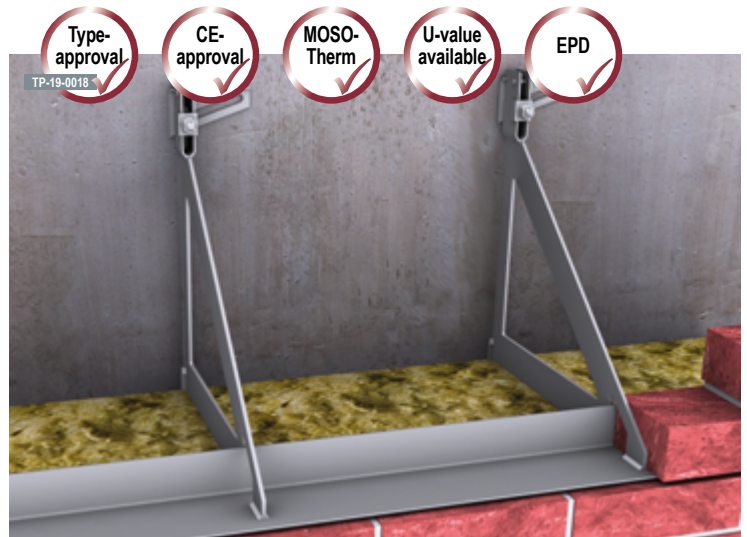

▲ Wall support with MOSO® angle-bracket anchor WK-N

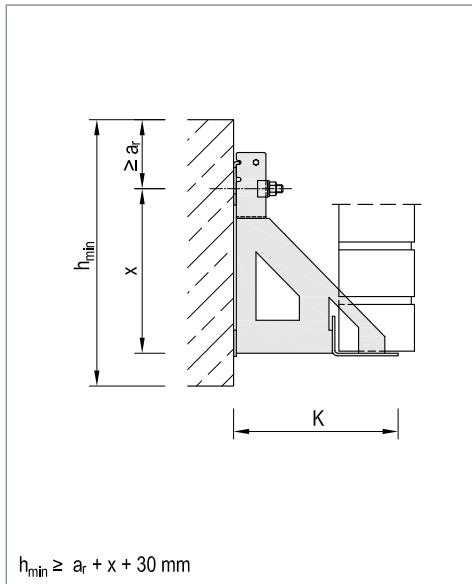

▲ MOSO® angle-bracket anchor WK-N

Use and application

- Particularly suited for invisible support
- Can also be used in corner and edge areas
- Support the entire surface of the angle until the mortar is set

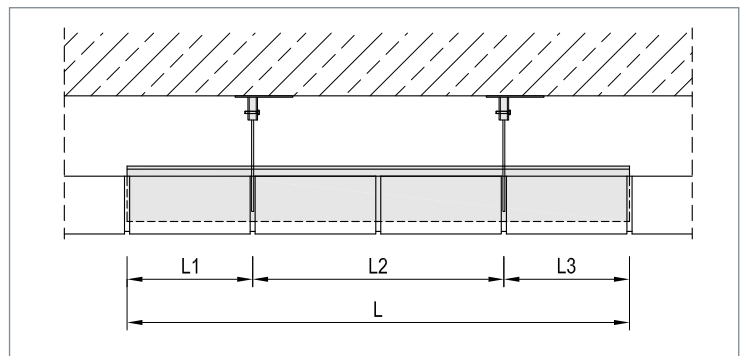

▲ Length dimensioning acc. to local conditions

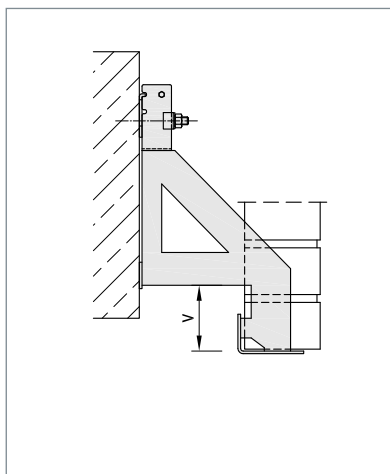

▲ WK-NV with offset

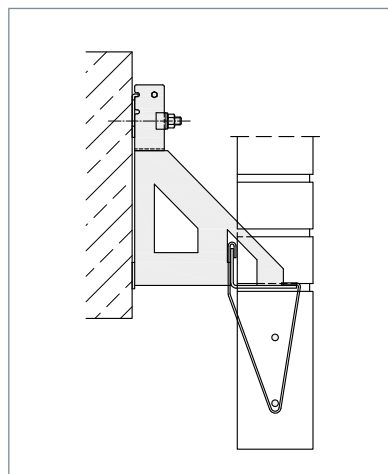

▲ WK-N with wire binder type 1

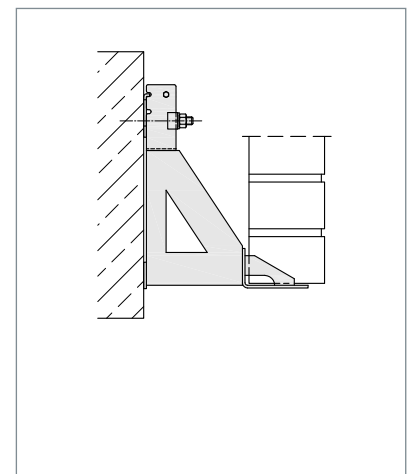

▲ Type WK-NX with welded-in gusset

Technical data / measurement chart

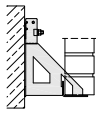
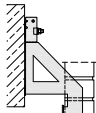

WK-N / WK-NV

Type / Design	Load stage	4.0 kN		8.0 kN		12.0 kN		
	Wall clearance ① [mm]	Cantilever length K [mm]	Bracket height x [mm]	Cantilever length K [mm]	Bracket height x [mm]	Cantilever length K [mm]	Bracket height x [mm]	
 WK-N	20 - 50	130	150	130	200	130	250	
	40 - 70	150	150	150	200	150	250	
	60 - 90	170	150	170	200	170	250	
	80 - 110	190	150	190	200	190	250	
	100 - 130	210	150	210	200	210	250	
	120 - 150	230	175	230	250	230	300	
 WK-NV	140 - 170	250	175	250	250	250	300	
	160 - 190	270	175	270	250	270	300	
	180 - 210	290	175	290	250	290	300	
	200 - 230	310	175	310	300	310	350	
	220 - 250	330	175	330	300	330	350	
	240 - 270	350	200	350	350	350	400	
	Larger wall clearances on request							
	Angle width [mm]	B	100		100		100	
Angle length [mm]	L	up to 4000		up to 4000		up to 4000		
Mounting size		M10 / M12		M10 / M12		M12 / M16		
Recommended fixing ②	Dowels fischer	FAZ II 12/60 A4 Edge clearance $a_e \geq 80$ mm		RG M12x200 A4 with RSB 12 Edge clearance $a_e \geq 140$ mm		RG M16x250 A4 with RSB 16 Edge clearance $a_e \geq 140$ mm		
	Dowels Hilti	HST3-R M12x165 90/70 Edge clearance $a_e \geq 80$ mm		HAS-U A4 M12x200 mit HVU2 Edge clearance $a_e \geq 140$ mm		HAS-U A4 M16x260 mit HVU2 Edge clearance $a_e \geq 140$ mm		
	Anchor channels	MBA-CE 38/17 with MHK 38/17 M12x80 Edge clearance $a_e \geq 75$ mm		MBA-CE 50/31 with MHK 50/30 M12x80 Edge clearance $a_e \geq 150$ mm		MBA-CE 52/34 with MHK 50/30 M16x100 Edge clearance $a_e \geq 200$ mm		

Example order: WK - N - 170 - 4.0 - 1500 - 2R

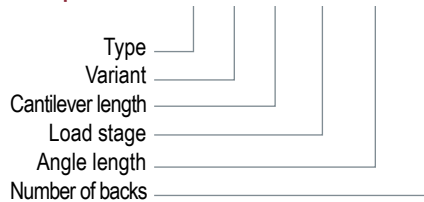

- ① Specifications apply to facing bricks of 115 mm thickness, and a superimposed load of ≤ 2 storeys. Otherwise, support brackets should be adjusted acc. to DIN EN 1996-2/NA.
 ② The stated edge clearances are benchmarks. The anchoring should be validated in consideration of the relevant installation situation.

Recommended anchor selection

Superimposed load [m]	Load ③ [kN/m]	Angle length / No. Bracket backs	Load stage [kN]	Distribution L1 / L2 / L3
1.5	3.11	2000 mm / 2R	4.0	500 / 1000 / 500
2.0	4.14	1880 mm / 2R	4.0	400 / 1080 / 400
3.0	6.21	1250 mm / 2R	4.0	250 / 750 / 250
4.5	9.32	1630 mm / 2R	8.0	250 / 750 / 250
6.0	12.42	1250 mm / 2R	8.0	250 / 750 / 250
9.0	18.63	1250 mm / 2R	12.0	250 / 750 / 250
12.0	24.84	880 mm / 2R	12.0	190 / 500 / 190

③ Assumption: Facing brick 115 mm thickness with $\gamma' = 18$ kN/m³

Cross-reference for additional information

Pages	Topic
32	Corner support with type WK-Z
37	Lintel construction with DB / HB
70	Corners and edging
70	Abutment for suspended facing
79 - 91	Technical details

Tender text

Delivery and professional installation of ... pieces of MOSO® angle support bracket type WK-N-210¹⁾-8.0²⁾-1000³⁾-2R⁴⁾ with type approved support anchor head, incl. dowels for cracked concrete⁵⁾.

Alternatively:

Delivery and professional installation of ... m wall bracing with MOSO® angle support bracket type WK-N with type approved support anchor head for a brickwork height (insulation and air layer) of ... cm, facing brick thickness of ... cm, incl. dowels for cracked concrete⁵⁾.

- 1) Cantilever length acc. to table
 2) Load stage acc. to table
 3) Length of element
 4) Number of backs
 5) Fixing acc. to table

Note:

If fixed with hammerhead bolts, the associated support anchor channel should be put out for tender.



For wall bracing at corners and pillars

WK-Z

Angle support brackets

Der MOSO® angle support bracket WK-Z with tension band, together with conventional load-bearing anchors, provides a further option for anchoring high superimposed loads, e.g. at external corners, if the structural shell situation allows it by means of a reinforced concrete wall or column. The tension band bracket is also a practical option for pier supports.

Product info

- Load stages: 4.0 kN - 25.0 kN
- Wall clearances: 20 mm - 370 mm (> on request)
- Material: stainless steel
corrosion resistance class (CRC) I-V
- Validation: structural calculation

Use and application

- Type WK-ZD especially for corner supports
- Strong suitability for abutment supports
- Type WK-ZG for very uneven concrete surfaces
- Support the entire surface of the angle until the mortar is set



▲ Corner support with MOSO® angle support bracket WK-Z

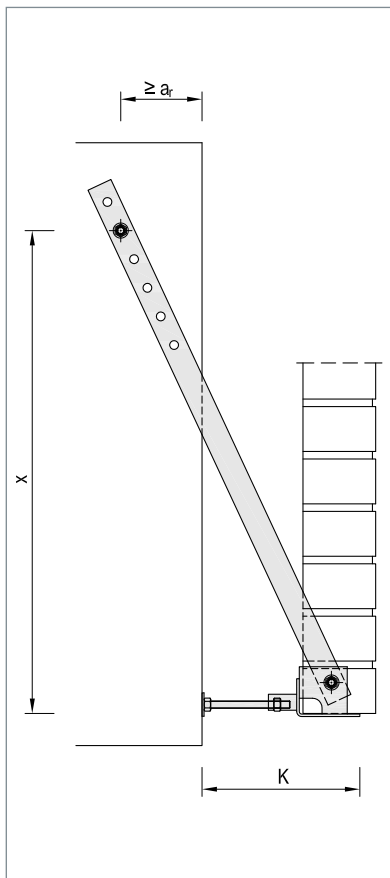

▲ MOSO® angle-bracket anchor WK-Z

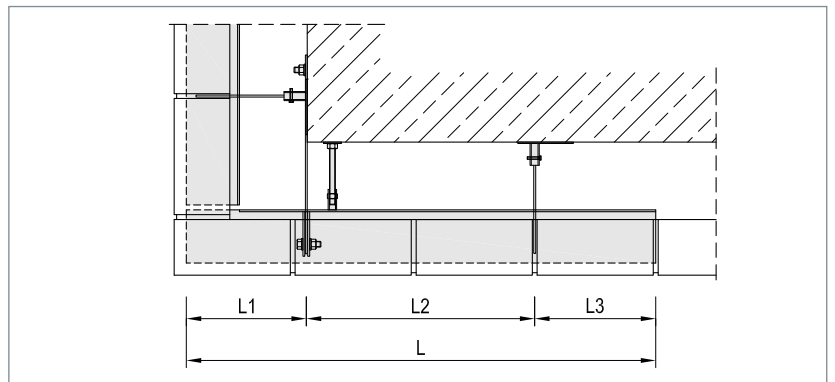

▲ Length dimensioning acc. to local conditions

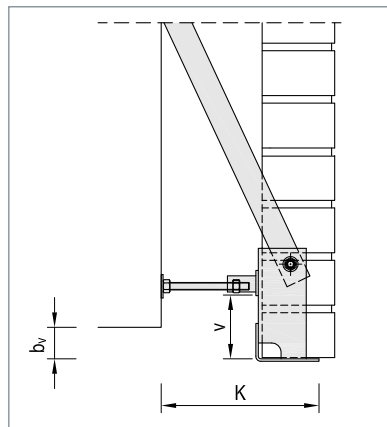

▲ WK-ZV with offset

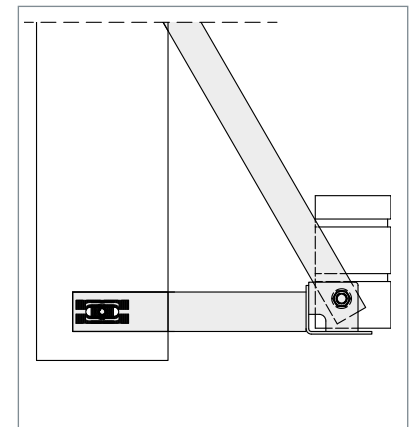

▲ WK-ZS with flat support in alignment with the reinforced concrete structural edge

Technical data / measurement chart

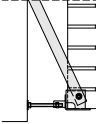
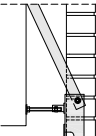

WK-Z / WK-ZV

Type / Design	Load stage	4.0 kN		8.0 kN		12.0 kN	
	Wall clearance ① [mm]	Cantilever length K [mm]	min. bracket height x ③ [mm]	Cantilever length K [mm]	min. bracket height x ③ [mm]	Cantilever length K [mm]	min. bracket height x ③ [mm]
WK-Z 	20 - 50	130	550	130	550	130	650
	40 - 70	150	550	150	600	150	700
	60 - 90	170	600	170	650	170	750
	80 - 110	190	650	190	700	190	800
	100 - 130	210	700	210	700	210	850
	120 - 150	230	700	230	750	230	900
WK-ZV 	140 - 170	250	750	250	800	250	950
	160 - 190	270	800	270	850	270	950
	180 - 210	290	850	290	900	290	1000
	200 - 230	310	900	310	950	310	1050
	220 - 250	330	950	330	1000	330	1100
	240 - 270	350	1000	350	1050	350	1150
Larger wall clearances on request							
Angle width [mm]	B	100		100		100	
Angle length [mm]	L	up to 4000		up to 4000		up to 4000	
Mounting size		M10 / M12		M12		M16	
Recommended fixing ②	Dowels fischer	FAZ II 12/30 A4 Edge clearance a _r ≥ 150 mm		FAZ II 12/30 A4 Edge clearance a _r ≥ 175 mm		FAZ II 16/25 A4 Edge clearance a _r ≥ 200 mm	
	Dowels Hilti	HST3-R M12x165 90/70 Edge clearance a _r ≥ 80 mm		HAS-U A4 M12x200 mit HVU2 Edge clearance a _r ≥ 140 mm		HAS-U A4 M16x260 mit HVU2 Edge clearance a _r ≥ 140 mm	

Example order: WK - ZAL - 210 - 8.0 - 1210 - 2R

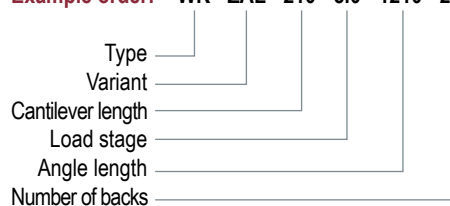

- ① Specifications apply to facing bricks of 115 mm thickness, and a superimposed load of ≤ 2 storeys. Otherwise, support brackets should be adjusted acc. to DIN EN 1996-2/NA.
- ② The stated edge clearances are benchmarks. The anchoring should be validated in consideration of the relevant installation situation.
- ③ Bracket height x is dependent upon the tie strap incline.

Recommended anchor selection

Superimposed load [m]	Load ③ [kN/m]	Angle length / No. Bracket backs	Load stage [kN]	Distribution L1 / L2 / L3
1.5	3.12	1500 mm / 2R	4.0	L1 = L3 = Cantilever length K L2 = L - L1 - L3
2.0	4.14	1500 mm / 2R	4.0	
3.0	6.21	1500 mm / 2R	8.0	
4.5	9.32	1250 mm / 2R	8.0	
6.0	12.42	1000 mm / 2R	8.0	
9.0	18.63	1000 mm / 2R	12.0	
12.0	24.84	750 mm / 2R	12.0	

③ Assumption: Facing brick 115 mm thickness with $\gamma' = 18 \text{ kN/m}^3$

Tender text

Delivery and professional installation of ... pieces of MOSO® angle support bracket type WK-ZD-210¹⁾-8.0²⁾-1000³⁾-2R⁴⁾ with type approved support anchor head, incl. dowels for cracked concrete⁵⁾.

Alternatively:

Delivery and professional installation of ... m wall bracing with MOSO® angle support bracket type WK-ZD with type approved support anchor head for a brickwork height (insulation and air layer) of ... cm, facing brick thickness of ... cm, incl. dowels for cracked concrete⁵⁾.

¹⁾ Cantilever length acc. to table

²⁾ Load stage acc. to table

³⁾ Length of element

⁴⁾ Number of backs

⁵⁾ Fixing acc. to table

Cross-reference for additional information

Pages	Topic
28 - 31	Wall support with WK-D / WK-N
37	Lintel construction with DB / HB
70	Corners and edging
70	Abutment for suspended facing
79 - 91	Technical details



WK-K / WK-KV

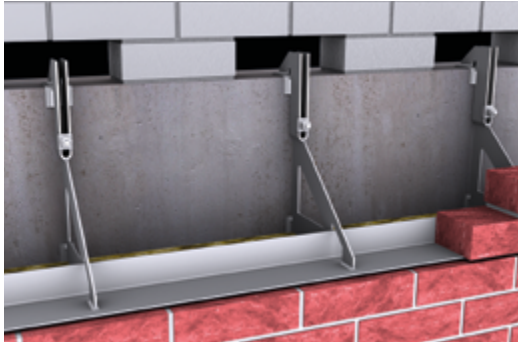

▲ Wall bracing with MOSO® angle bracket anchor WK-K

The MOSO® angle support bracket WK-K rests on the concrete with its claw. This relieves the fastening so that high loads can be anchored securely on the face side even with low concrete heights.

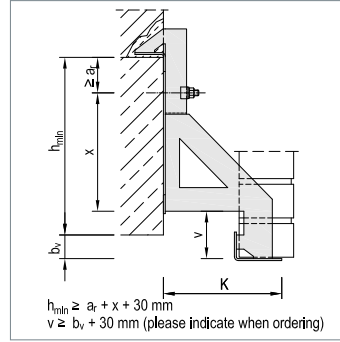

▲ MOSO® angle support bracket WK-K

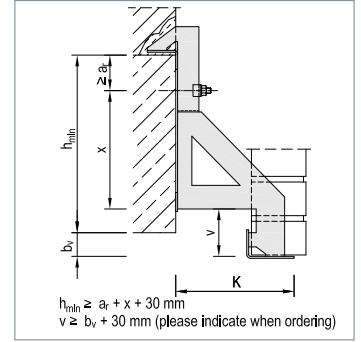

▲ WK-KV with offset

Example order: **WK - K - 230 - 7.0 - 1000 - 2R**

Type	_____
Variant	_____
Cantilever length	_____
Load stage	_____
Angle length	_____
Number of backs	_____

WK-O / WK-OV

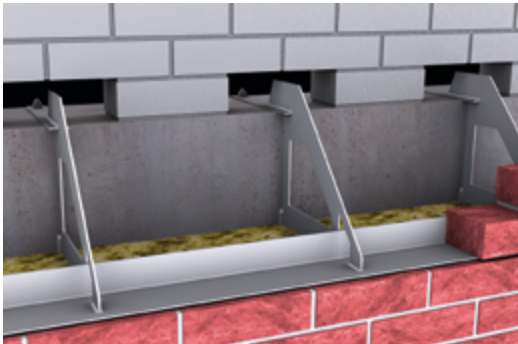

▲ Wall bracing with MOSO® angle bracket anchor WK-O

The MOSO® angle support bracket WK-O is fixed to the concrete slab from above. This allows anchoring with dowel installation even at low concrete heights.

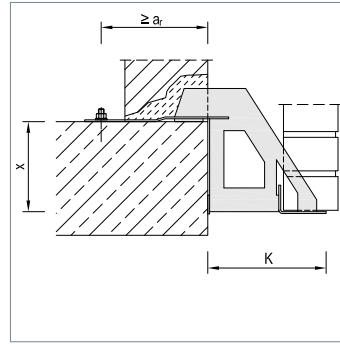

▲ MOSO® angle support bracket WK-K

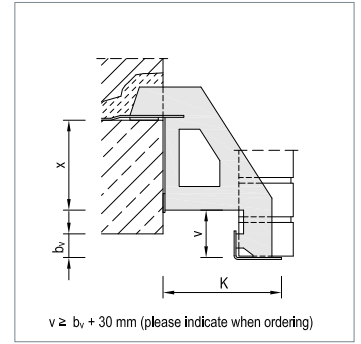

▲ WK-KV with offset

Example order: **WK - O - 170 - 7.0 - 1500 - 2R**

Type	_____
Variant	_____
Cantilever length	_____
Load stage	_____
Angle length	_____
Number of backs	_____

WK-M / WK-MV

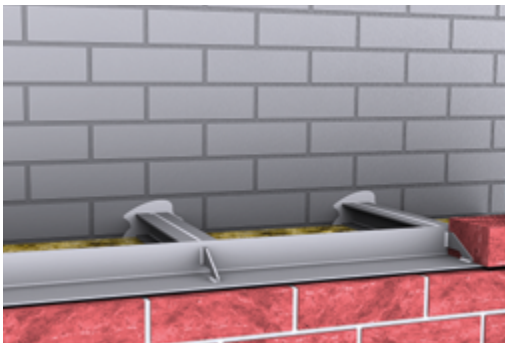

▲ Wall bracing with MOSO® angle bracket anchor WK-M

The MOSO® angle support bracket WK-M is set into the masonry. This anchor is preferred if the anchoring base does not allow anchor installation. To keep the installation effort as low as possible, an individual design by our engineering office is advisable.

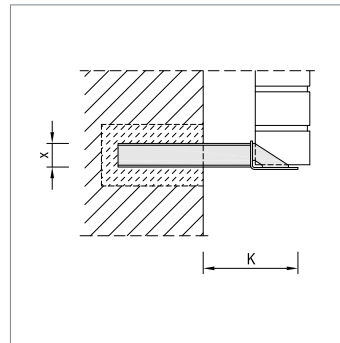

▲ MOSO® angle support bracket WK-M

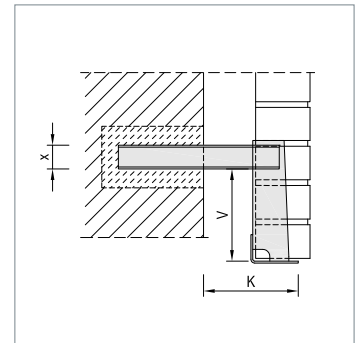

▲ WK-MV with offset

Example order: **WK - M - 170 - 4.0 - 1500 - 2R**

Type	_____
Variant	_____
Cantilever length	_____
Load stage	_____
Angle length	_____
Number of backs	_____



WA-Ü / WA-Z



WA-D / WA-M



WA-S

MOSO® Angle bearings



For covering masonry openings

WA-Ü / WA-Z

Angle bearing

The MOSO® angle bearing WA-Ü bridges a lintel opening. Since the angle only has to be laid on, additional fastening is not necessary.

The MOSO® angle bearing WA-Z is used as an intermediate angle for bracing with single bracket anchors and enables variable bracket anchor spacing due to different lengths.

Product info

- Width of support: 90, 95 and 100 mm
- Width of opening: up to 2.26 m (> on request)
- Material: stainless steel
corrosion resistance class (CRC) I-V
- Validation: structural calculation

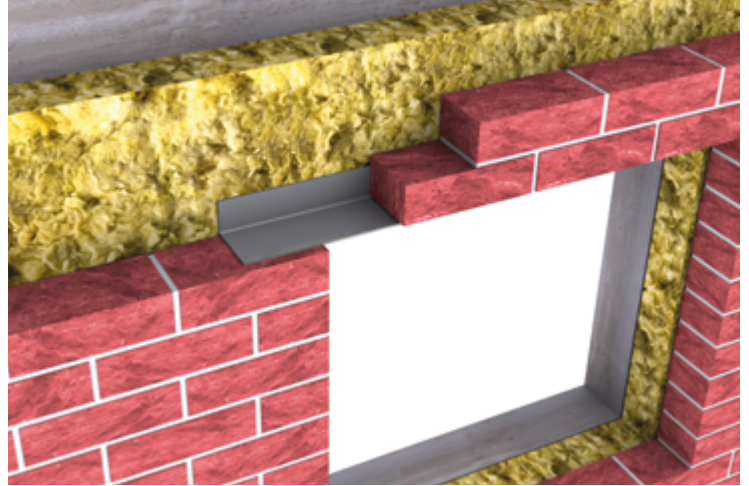

▲ Opening overlap with MOSO® angle bearing WA-Ü

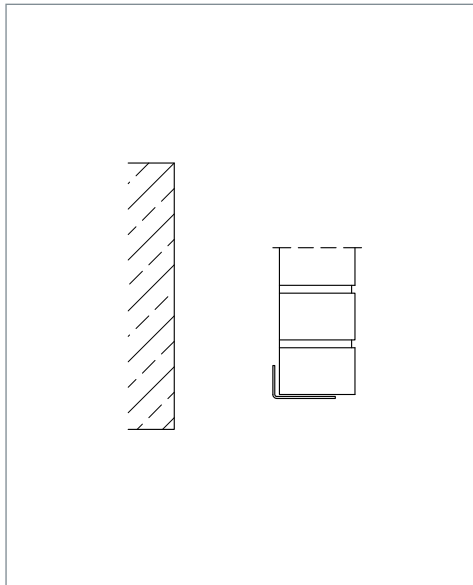

▲ MOSO® angle bearing WA-Ü

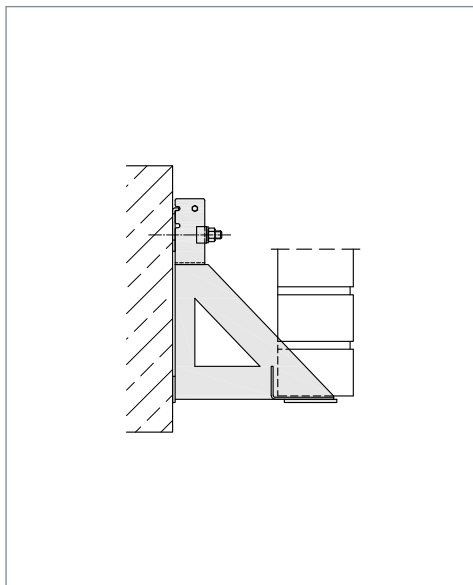

▲ MOSO® angle bearing WA-Z combined with EK-U

Use and application

- As bridging angle for lintel openings
- The entire surface of the angle should be supported until the mortar is set

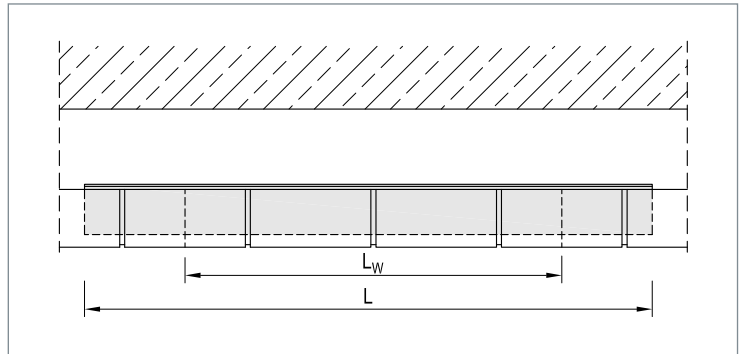

▲ Angle bearing WA-Ü as lintel overlap

Use and application

- As intermediate angle for single-bracket anchors
- The entire surface of the angle should be supported until the mortar is set

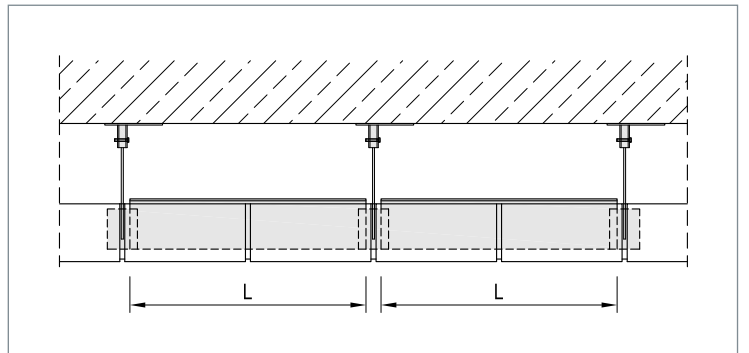

▲ Angle bearing WA-Z as intermediate angle



WA-Ü / WA-Z

Type / design	Profile (height/thickness of angle) in [mm]														GW	
	L _w [m]	L [mm]	All loads applied WITHOUT arching effect (GW)											h _G [m]		
			0,5	0,75	1	1,25	1,5	1,75	2	2,25	2,5	2,75	3			
WA-Ü Assumed parameters: bearing angle; max w = 1/300; γ = 18 kN/m ³ ; brick width 11,5 cm Additional tables: 	0,76	950	42/3	42/3	42/3	42/3	42/3	42/3	42/3	42/3	42/3	42/3	42/3	0,94	42/3	
	0,885	1100	42/3	42/3	42/3	42/3	42/3	56/3	56/3	56/3	56/3	56/3	56/3	1,05	42/3	
	1,01	1200	42/3	42/3	42/3	56/3	56/3	56/3	56/3	56/3	58/4	58/4	58/4	1,17	42/3	
	1,135	1350	42/3	56/3	56/3	56/3	56/3	58/4	58/4	58/4	74/4	74/4	74/4	1,28	42/3	
	1,26	1450	42/3	56/3	56/3	56/3	58/4	58/4	74/4	74/4	74/4	74/4	74/4	1,4	56/3	
	1,385	1600	56/3	56/3	58/4	58/4	74/4	74/4	74/4	74/4	74/4	74/4	76/5	76/5	1,51	56/3
	1,51	1700	56/3	58/4	58/4	74/4	74/4	74/4	74/4	74/4	76/5	76/5	100/5*	100/5*	1,62	58/4
	1,635	1850	56/3	74/4	74/4	74/4	74/4	74/4	76/5	76/5	100/5*	100/5*	100/5*	100/5*	1,74	74/4
	1,76	2000	58/4	74/4	74/4	74/4	76/5	100/5*	100/5*	100/5*	100/5*	100/5*	100/5*	100/5*	1,85	74/4
	1,885	2150	58/4	74/4	74/4	76/5	100/5*	100/5*	100/5*	100/5*	100/5*	100/5*	100/5*	100/5*	1,96	76/5
	2,01	2250	74/4	74/4	76/5	100/5*	100/5*	100/5*	100/5*	100/5*	100/6*	100/6*	120/5*	120/5*	2,08	100/5
	2,135	2400	74/4	76/5	100/5*	100/5*	100/5*	100/5*	100/5*	100/6*	120/5*	120/5*	120/5*	120/5*	2,19	100/5
	2,26	2500	74/4	76/5	100/5*	100/5*	100/5*	100/6*	100/6*	120/5*	120/5*	120/5*	130/5*	130/5*	2,31	100/5
	Angle width [mm] for 115 mm thick facing brick									90 mm - up to two-storey superimposed load - 100 mm up to 12 m brickwork!						
	Angle width [mm] for 100 mm thick facing brick									95 mm - up to two-storey superimposed load						
	Angle width [mm] for 90 mm thick facing brick									90 mm - up to two-storey superimposed load						

Dimensions and bends for other profiles, with other weights and bends outside the stock guide on request (see QR code).

* No bearing angles

If profiles WITH arching effect are used, the closed brickwork height of column h_G must be achieved (see system sketch below).

The required chamfer is shown in column GW.

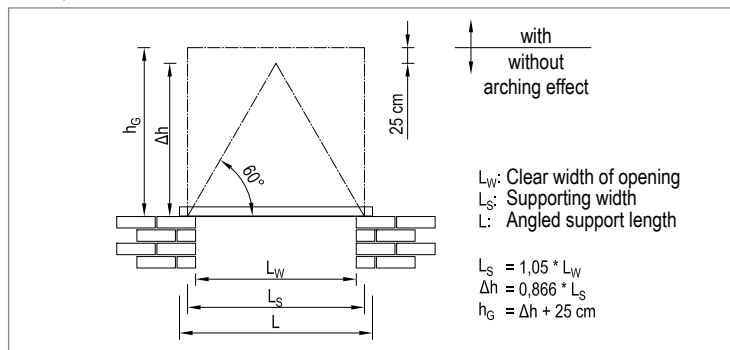

▲ System diagram

Example order: WA - Ü - 100/58/4 - 1450

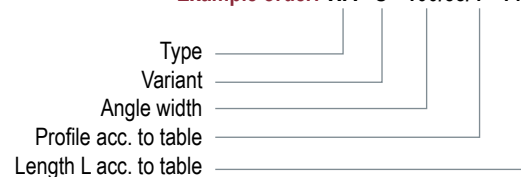

Tender text

Delivery and professional installation of ... pieces of MOSO® angle bearing WA-Ü-100/60/4-1450¹⁾.

Alternatively:

Delivery and professional installation of ... pieces of lintel overlap for clear spans L_w ... m with MOSO® angle bearing type WA-Ü for a brickwork height of ... m, facing brick thickness of ... cm.

¹⁾ acc. to table

We are also happy to offer you the later visible angle soffits as a glass bead blasted version.

This surface refinement enhances the appearance in the later installation state.

Type / variant	Intermediate angle	Anchor spacing a _k [cm]	Application with single-bracket anchor type
WA-Z 	WA-Z-95/50/3-980	100.0	EK-D, EK-U, EK-M
	WA-Z-95/30/3-730	75.0	
	WA-Z-95/20/1.5-480	50.0	
	WA-Z-95/20/1.5-355	37.5	

Cross-reference for additional information

Pages	Topic
16 - 19	Wall support with MOSO® single-bracket anchor EK-D / EK-U
37	Lintel formation with MOSO® accessory DB
79 - 91	Technical details
90	Dimensioning principles for masonry support

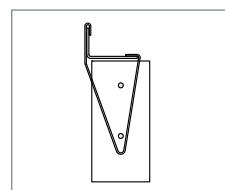

▲ Grenadier layer can be mounted under WA-Ü by means of DB



Angle bearing

With the MOSO® angle bearing WA-D, even large wall distances can be bridged by welded-in diagonal braces.

The MOSO® Angle bearing WA-M allows direct mounting to the anchoring base.

Both types are used when the support remains visible and a closed soffit is desired.

Product info

- Load stages: 1.2 kN - 3.2 kN
- Wall clearances: 10 mm - 200 mm
- Material: stainless steel
corrosion resistance class (CRC) I-V
- Validation: structural calculation



▲ Wall support with MOSO® angle bearing WA-D

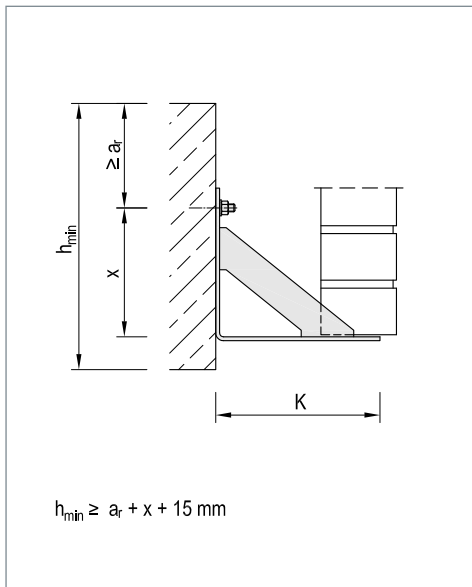

▲ MOSO® angle bearing WA-D

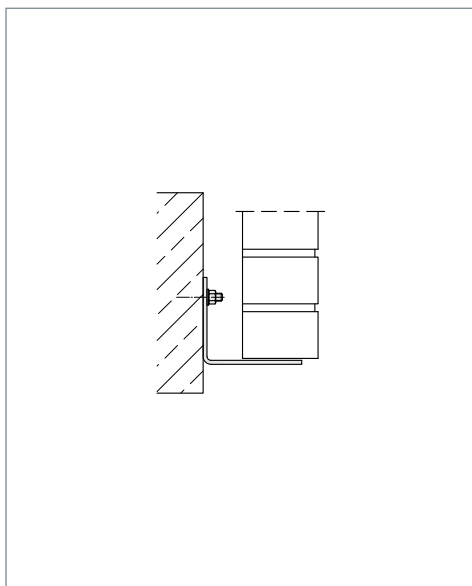

▲ MOSO® angle bearing WA-M

Use and application

- For visible wall bracing
- Limited use in corner and edge areas
- The entire surface of the angle should be supported until the mortar is set

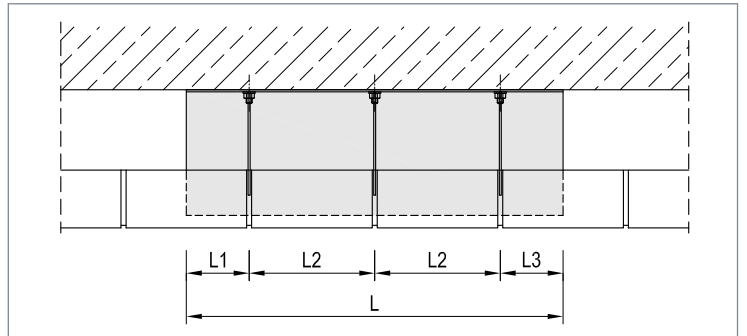

▲ Angle bearing WA-D as foot bracing

Use and application

- For visible wall bracing
- The entire surface of the angle should be supported until the mortar is set

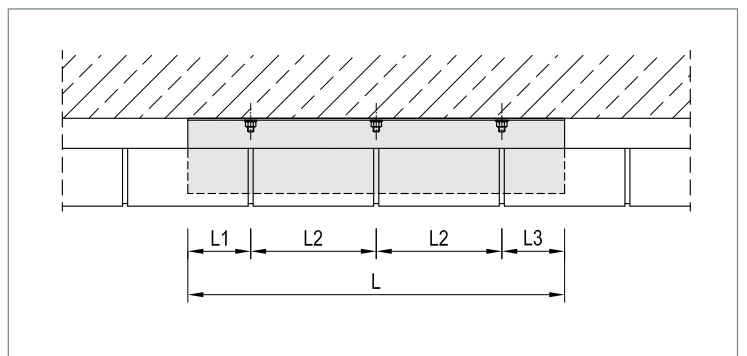

▲ Angle bearing WA-M as foot bracing

Technical data / measurement chart



WA-D / WA-M

Type / Design	Load stage	1.5 kN / fixing point		3.2 kN / fixing point	
	Wall clearance ① [mm]	Cantilever length K [mm]	Bracket height x [mm]	Cantilever length K [mm]	Bracket height x [mm]
WA-D 	20 - 40	130	104	130	102
	40 - 60	150	124	150	122
	60 - 80	170	144	170	142
	80 - 100	190	174	190	172
	100 - 120	210	194	210	192
	120 - 140	230	224	230	222
	140 - 160	250	244	250	242
	160 - 180	270	264	270	262
	180 - 200	290	284	290	282
Larger wall clearances on request					
Material thickness	T	4		6	
Length of element	up to 4000			up to 4000	
Mounting size	M10 / M12			M10 / M12	
Recommended fixing ②	Dowels	FAZ II 10/10 A4 Edge clearance a _r ≥ 60 mm		FAZ II 12/10 A4 Edge clearance a _r ≥ 80 mm	

Type / Design	Load stage	1.2 kN / fixing point		2.1 kN / fixing point		3.2 kN / fixing point	
	Wall clearance ① [mm]	Cantilever length K [mm]	Bracket height x [mm]	Cantilever length K [mm]	Bracket height x [mm]	Cantilever length K [mm]	Bracket height x [mm]
WA-M 	10 - 20	100	74	100	72	100	70
	30 - 40	120	94	120	92	120	90
Material thickness	T	4		6		8	
Length of element	up to 4000			up to 4000		up to 3000	
Mounting size	M10 / M12			M10 / M12		M10 / M12	
Recommended fixing ②	Dowels	FAZ II 10/10 A4 Edge clearance a _r ≥ 60 mm		FAZ II 10/10 A4 Edge clearance a _r ≥ 60 mm		FAZ II 12/30 A4 Edge clearance a _r ≥ 80 mm	

- ① Specifications apply to facing bricks of 115 mm thickness, and a superimposed load of ≤ 2 storeys. Otherwise, support brackets should be adjusted acc. to DIN EN 1996-2/NA.
 ② The stated edge clearances are benchmarks. The anchoring should be validated in consideration of the relevant installation situation.

Example order:

WA - D - 230 - 3.2 - 1000 - 4R

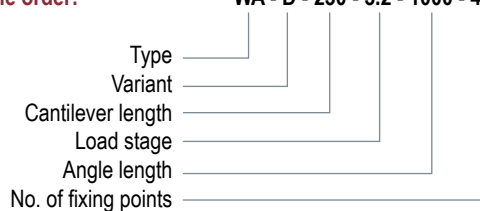

Tender text

Delivery and professional installation of ... pieces of MOSO® angle bearing type WA-D-210¹⁾-3.2²⁾-1000³⁾-4R⁴⁾, incl. dowels for cracked concrete⁵⁾.

Alternatively:

Delivery and professional installation of ... m wall bracing with MOSO® angle bearing type WA-D for a brickwork height of ... m, wall clearance (insulation and air layer) of ... cm, facing brick thickness of ... cm, incl. dowels for cracked concrete⁵⁾.

¹⁾ Cantilever length acc. to table

²⁾ Load stage acc. to table

³⁾ Length of element

⁴⁾ No. of fixing points

⁵⁾ Fixing acc. to table

Standard dimensions WA-D and WA-M

Length of element [mm]	Qty. Fixings	Distribution [mm]
500	2	125 / 250 / 125
750	3	125 / 2x250 / 125
1000	4	125 / 3x250 / 125
1250	5	125 / 4x250 / 125
1500	6	125 / 5x250 / 125

Cross-reference for additional information

Pages	Topic
79 - 91	Technical details



The MOSO® Angle support WA-S in special design are individually calculated by our engineering office to ensure optimum solutions even in difficult conditions.

Product info

- Material: stainless steel
corrosion resistance class (CRC) III*
- Validation: structural calculation
- * Further corrosion resistance classes on request

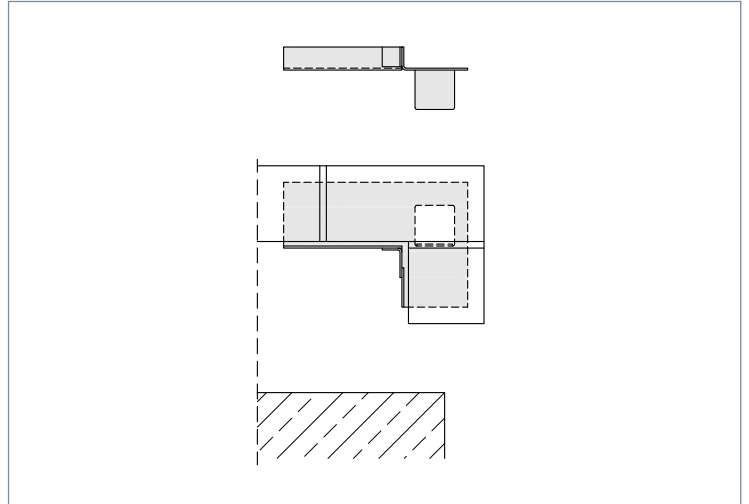

▲ Soffits

Use and application

- Dimensioning of special support brackets acc. to structural and constructional requirements.

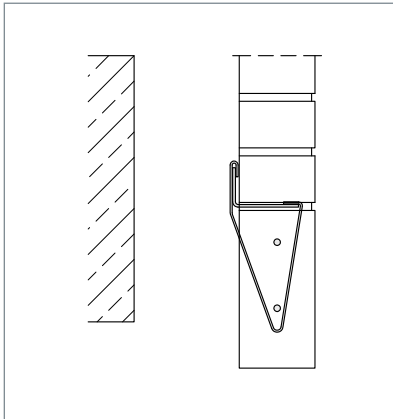

▲ For suspended brick-on-edge

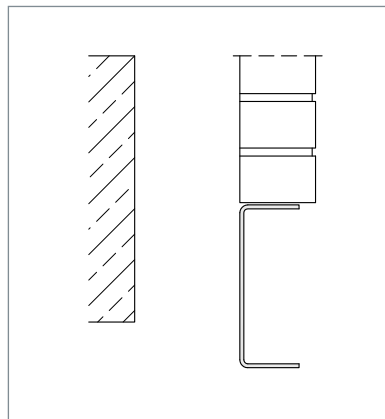

▲ Visual element as C-profile

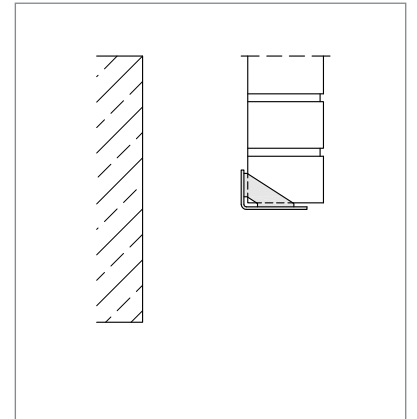

▲ WA-Ü with gusset

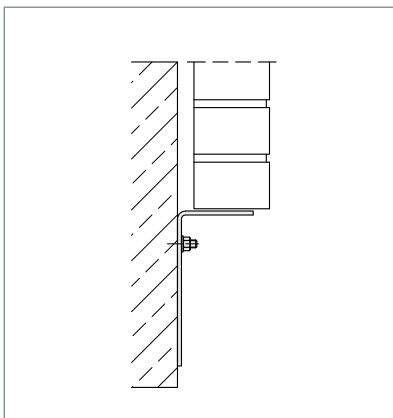

▲ As pillar support

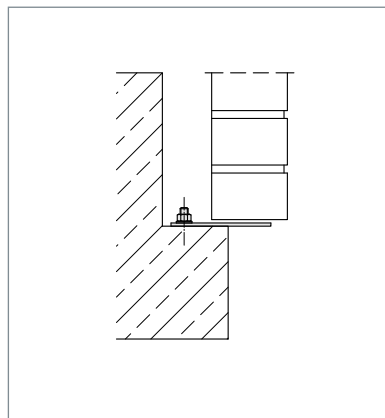

▲ As an extension of the support

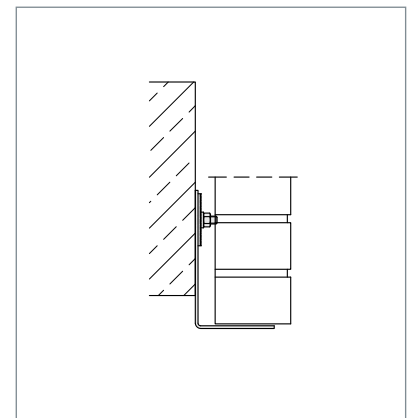

▲ With height adjustment

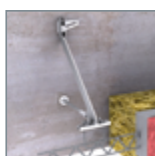

FB-D



FB-U



FB-S

MOSO[®] Fixings for precast part



Adjustable pressure screw

FB-D

The MOSO® precast part fixing FB-D with adjustable pressure screw for fastening precast concrete elements. The slim design allows for reduced heat transmission.

This anchor allows, depending on the fastening, a 3-dimensional adjustment possibility for an optimal assembly.

Product info

- Load stages: 4.0 kN - 25.0 kN
- Wall clearances: 20 mm - 370 mm (> on request)
- Height adjustment: ± 25 mm
- Material: stainless steel
corrosion resistance class (CRC) I-V
- Validation: support anchor head acc. to DIBt Approval Z-21.8-1892
type testing or structural calculation

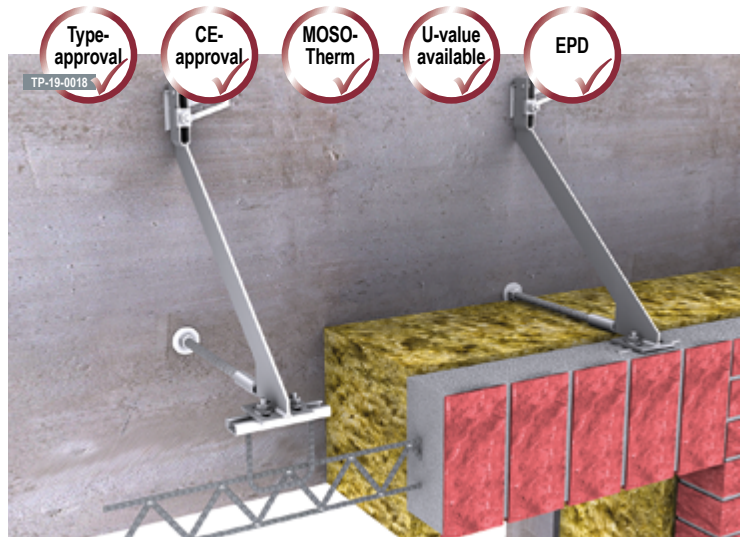

▲ Lintel support with MOSO® fixings for precast parts FB-D

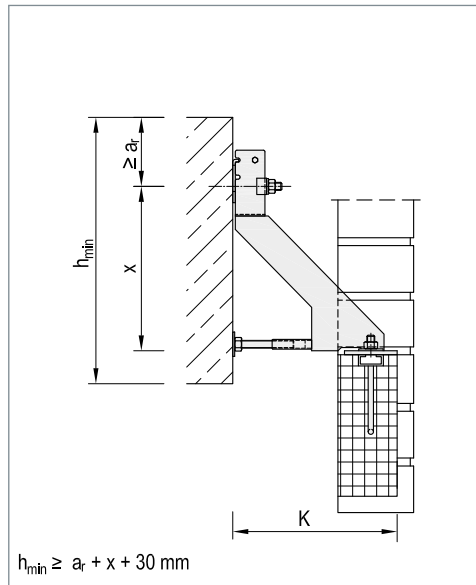

▲ MOSO® fixing for precast parts FB-D with anchor channel

Use and application

- For invisible support of pre-cast lintels
- 3-dimensional adjustment possible if used with an MBA-ES channel
- Can also be used in corner and edge areas

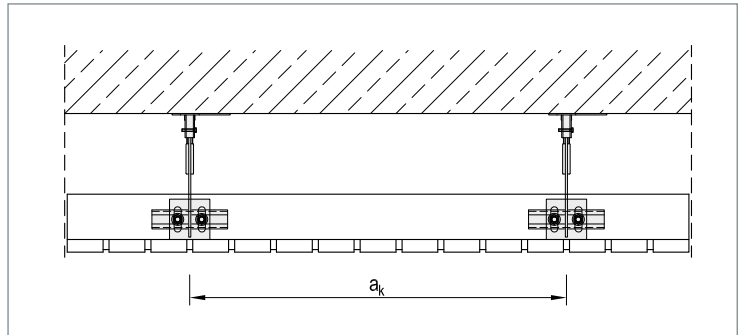

▲ Fixing for precast parts FB-D

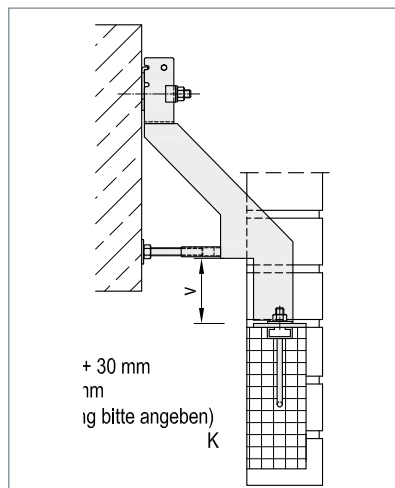

▲ FB-DV

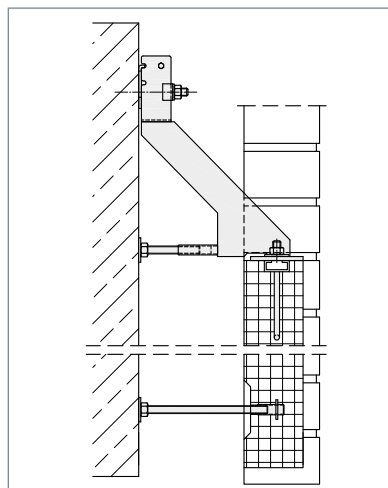

▲ FB-D with additional pressing screw

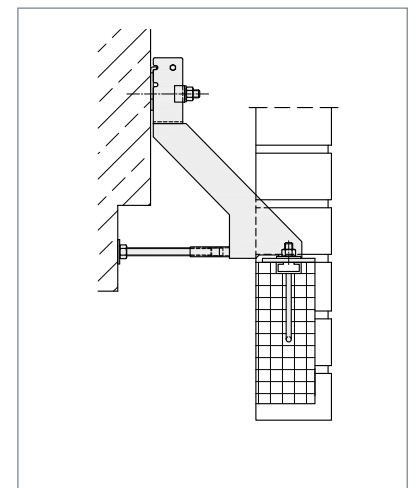

▲ FB-D with long pressing screw



FB-D / FB-DV

Type / Design	Load stage	4.0 kN		8.0 kN		12.0 kN	
	Wall clearance ① [mm]	Cantilever length K [mm]	Bracket height x [mm]	Cantilever length K [mm]	Bracket height x [mm]	Cantilever length K [mm]	Bracket height x [mm]
FB-D	90 - 110	190	150	190	200	190	250
	100 - 130	210	150	210	200	210	250
	120 - 150	230	175	230	250	230	300
	140 - 170	250	175	250	250	250	300
FB-DV	160 - 190	270	175	270	250	270	300
	180 - 210	290	175	290	250	290	300
	200 - 230	310	175	310	300	310	350
	220 - 250	330	175	330	300	330	350
	240 - 270	350	200	350	350	350	400
Larger wall clearances on request							
Support plate	W / L / T	80 / 80 / 4 with 2 LL 11x50		80 / 80 / 6 with 2x LL 13x50		80 / 80 / 8 with 2x LL 13x50	
Mounting size		M10 / M12		M10 / M12		M12 / M16	
Recommended fixing ②	Dowels	FAZ II 12/60 A4 Edge clearance $a_r \geq 80$ mm		RG M12x200 A4 with RSB 12 Edge clearance $a_r \geq 140$ mm		RG M16x250 A4 with RSB 16 Edge clearance $a_r \geq 140$ mm	
	Dowels Hilti	HST3-R M12x165 90/70 Edge clearance $a_r \geq 80$ mm		HAS-U A4 M12x200 mit HVU2 Edge clearance $a_r \geq 140$ mm		HAS-U A4 M16x260 mit HVU2 Edge clearance $a_r \geq 140$ mm	
	Anchor channels	MBA-CE 38/17 with MHK 38/17 M12x80 Edge clearance $a_r \geq 75$ mm		MBA-CE 50/31 with MHK 50/30 M12x80 Edge clearance $a_r \geq 150$ mm		MBA-CE 52/34 with MHK 50/30 M16x100 Edge clearance $a_r \geq 200$ mm	

- ① Specifications apply to facing bricks of 115 mm thickness, and a superimposed load of ≤ 2 storeys. Otherwise, support brackets should be adjusted acc. to DIN EN 1996-2/NA.
 ② The stated edge clearances are benchmarks. The anchoring should be validated in consideration of the relevant installation situation.

Example order: FB - D - 190 - 8.0

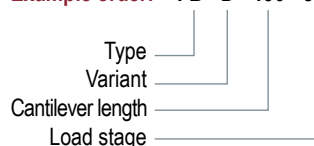

Fixing for precast part

Lintel mounting part ③	Screws	Washers	Nut
MBA 28/15 ES (4.0 kN)	2x MHK 28/15 M10x30	2x DIN 9021 M10	2x DIN 934 M10
MBA 38/17 ES (8.0 kN)	2x MHK 38/17 M10x30	2x DIN 125 M10	2x DIN 934 M10
MBA 38/17 ESL (12.0 kN)	2x MHK 38/17 M10x30	2x DIN 125 M10	2x DIN 934 M10

③ Part is regulated under Approval Z-21.4-1907

Tender text

Delivery and professional installation of ... pieces of MOSO® precast part fixing FB-D-210¹⁾-8.0²⁾ with type approved support anchor head, incl. dowels for cracked concrete³⁾ and type approved fixing for anchor channel MBA 38/17 ES concreted into the precast part⁴⁾.

Alternatively:

Delivery and professional installation of ... m wall bracing with MOSO® precast part fixing type FB-D with type approved support anchor head for a brickwork height of ... m, wall clearance (insulation and air layer) of ... cm, facing brick thickness of ... cm, incl. dowels for cracked concrete³⁾ and type approved fixing for anchor channel concreted into the precast part⁴⁾.

¹⁾ Cantilever length acc. to table

²⁾ Load stage acc. to table

³⁾ Fixing for in-situ concrete acc. to table

⁴⁾ Fixing for precast part acc. to table

Cross-reference for additional information

Pages	Topic
72 - 73	Lintel construction with MBA-ES
79 - 91	Technical details



Universal anchor for precast lintels

FB-U

Fixings for precast parts

The MOSO® precast part fixing FB-U is the universal anchor for fastening precast concrete elements.

Depending on the fastening, this anchor allows a 3-dimensional adjustment option for optimum installation.

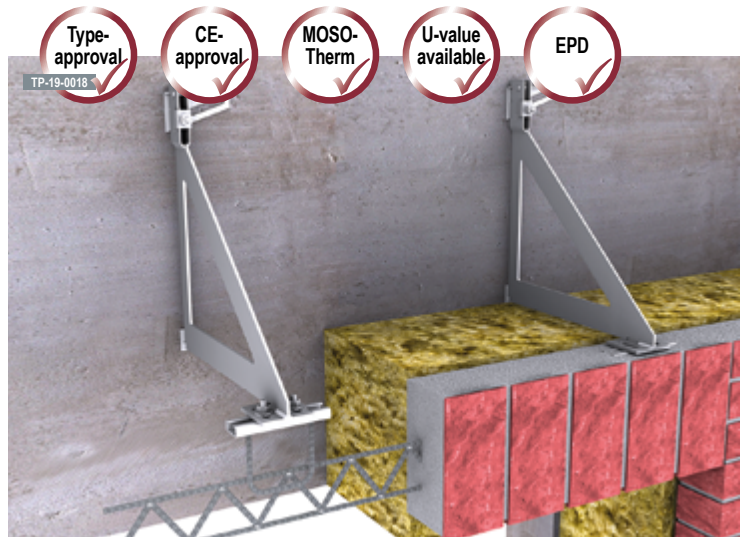

▲ Lintel support with MOSO® fixing for precast parts FB-U

Product info

- Load stages: 4.0 kN - 25.0 kN
- Wall clearances: 20 mm - 270 mm (> on request)
- Height adjustment: ± 25 mm
- Material: stainless steel
corrosion resistance class (CRC) I-V
- Validation: support anchor head acc. to DIBt Approval Z-21.8-1892
type testing or structural calculation

Use and application

- For invisible support of pre-cast lintels
- 3-dimensional adjustment possible if an ES channel is used in the precast part
- Can also be used in corner and edge areas

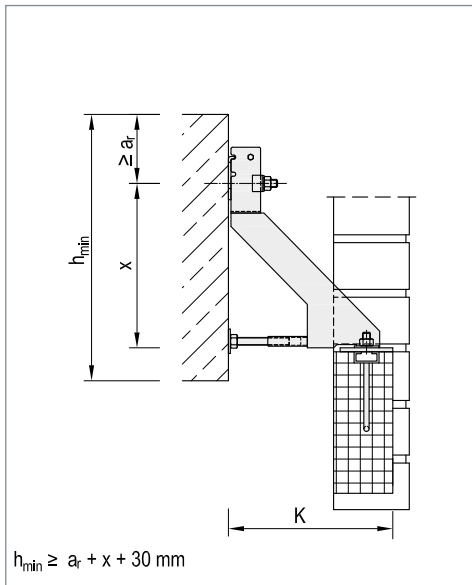

▲ MOSO® fixing for precast parts FB-U with support anchor

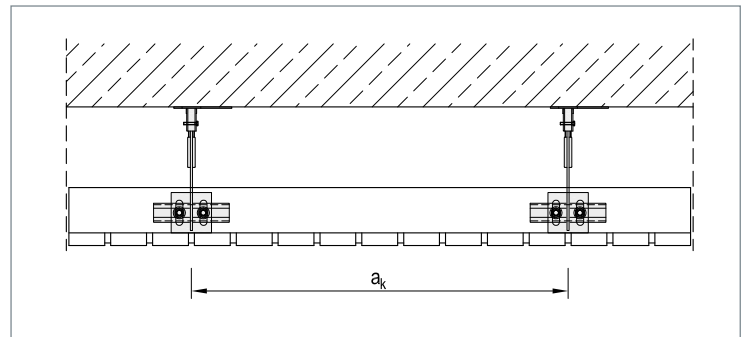

▲ Fixings for precast parts FB-U

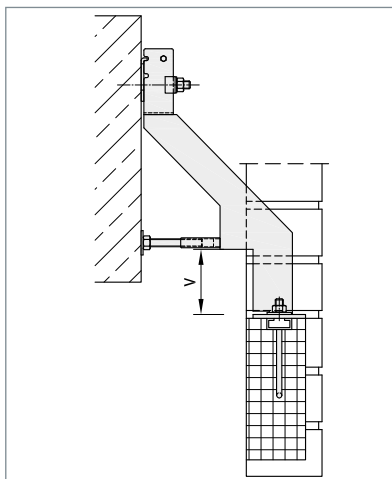

▲ FB-UV with offset

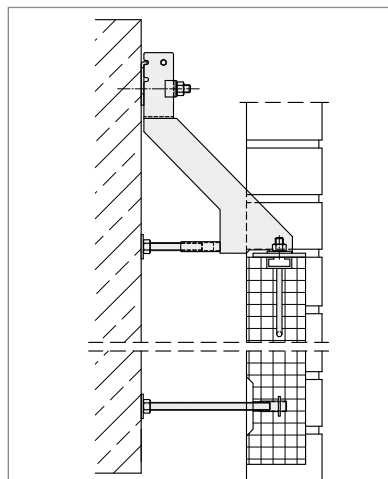

▲ FB-D with additional pressure screw

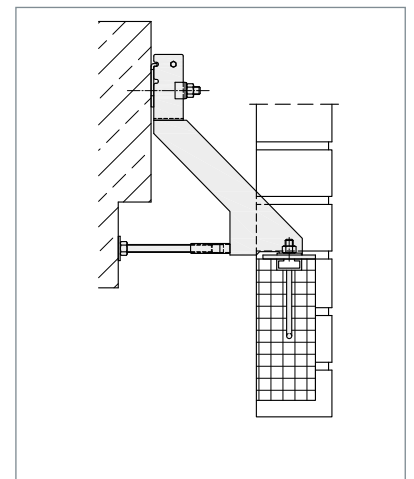

▲ FB-U with FB-ZK as rotation lock

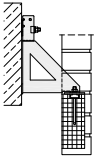
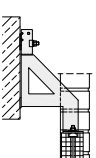

FB-U / FB-UV

Type / Design	Load stage	4.0 kN		8.0 kN		12.0 kN		
	Wall clearance ① [mm]	Cantilever length K [mm]	Bracket height x [mm]	Cantilever length K [mm]	Bracket height x [mm]	Cantilever length K [mm]	Bracket height x [mm]	
 FB-U	20 - 50	130	150	130	200	130	250	
	40 - 70	150	150	150	200	150	250	
	60 - 90	170	150	170	200	170	250	
	80 - 110	190	150	190	200	190	250	
	100 - 130	210	150	210	200	210	250	
	120 - 150	230	175	230	250	230	300	
 FB-UV	140 - 170	250	175	250	250	250	300	
	160 - 190	270	175	270	250	270	300	
	180 - 210	290	175	290	250	290	300	
	200 - 230	310	175	310	300	310	350	
	220 - 250	330	175	330	300	330	350	
	240 - 270	350	200	350	300	350	400	
	Larger wall clearances on request							
	Support plate	W / L / T	80 / 80 / 4 with 2 LL 11x50		80 / 80 / 6 with 2x LL 13x50		80 / 80 / 8 with 2x LL 13x50	
Mounting size		M10 / M12		M10 / M12		M12 / M16		
Recommended fixing ②	Dowels fischer	FAZ II 12/60 A4 Edge clearance $a_r \geq 80$ mm		RG M12x200 A4 with RSB 12 Edge clearance $a_r \geq 140$ mm		RG M16x250 A4 with RSB 16 Edge clearance $a_r \geq 140$ mm		
	Dowels Hilti	HST3-R M12x165 90/70 Edge clearance $a_r \geq 80$ mm		HAS-U A4 M12x200 mit HVU2 Edge clearance $a_r \geq 140$ mm		HAS-U A4 M16x260 mit HVU2 Edge clearance $a_r \geq 140$ mm		
	Anchor channel	MBA-CE 38/17 with MHK 38/17 M12x80 Edge clearance $a_r \geq 75$ mm		MBA-CE 50/31 with MHK 50/30 M12x80 Edge clearance $a_r \geq 150$ mm		MBA-CE 52/34 with MHK 50/30 M16x100 Edge clearance $a_r \geq 200$ mm		

Example order: FB - U - 190 - 8.0

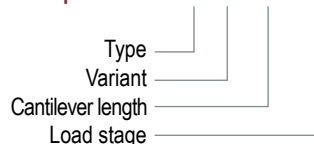

- ① Specifications apply to facing bricks of 115 mm thickness, and a superimposed load of ≤ 2 storeys. Otherwise, support brackets should be adjusted acc. to DIN EN 1996-2/NA.
 ② The stated edge clearances are benchmarks. The anchoring should be validated in consideration of the relevant installation situation.

Fixing for precast part

Lintel mounting part ③	Screws	Washers	Nut
MBA 28/15 ES (4.0 kN)	2x MHK 28/15 M10x30	2x DIN 9021 M10	2x DIN 934 M10
MBA 38/17 ES (8.0 kN)	2x MHK 38/17 M10x30	2x DIN 125 M10	2x DIN 934 M10
MBA 38/17 ESL (12.0 kN)	2x MHK 38/17 M10x30	2x DIN 125 M10	2x DIN 934 M10

③ Part is regulated under Approval Z-21.4-1907

Tender text

Delivery and professional installation of ... pieces of MOSO® precast part fixing FB-U-210¹⁾-8.0²⁾ with type approved support anchor head, incl. dowels for cracked concrete³⁾ and type approved fixing for anchor channel MBA 38/17 ES concreted into the precast part⁴⁾.

Alternatively:

Delivery and professional installation of ... m wall bracing with MOSO® precast part fixing type FB-U with type approved support anchor head for a brickwork height of ... m, wall clearance (insulation and air layer) of ... cm, facing brick thickness of ... cm, incl. dowels for cracked concrete³⁾ and type approved fixing for anchor channel concreted into the precast part⁴⁾.

¹⁾ Cantilever length acc. to table

²⁾ Load stage acc. to table

³⁾ Fixing for in-situ concrete acc. to table

⁴⁾ Fixing for precast part acc. to table

Cross-reference for additional information

Pages	Topic
72 - 73	Lintel construction with MBA-ES
79 - 91	Technical details

Note:

Parts to be concreted in (anchor channels) should be put out to tender separately.



The MOSO® FB-S precast part fixing in special design is individually calculated by our engineering office to ensure optimum solutions even in difficult conditions.

Product info

- Material: stainless steel
corrosion resistance class (CRC) I-V
- Validation: structural calculation

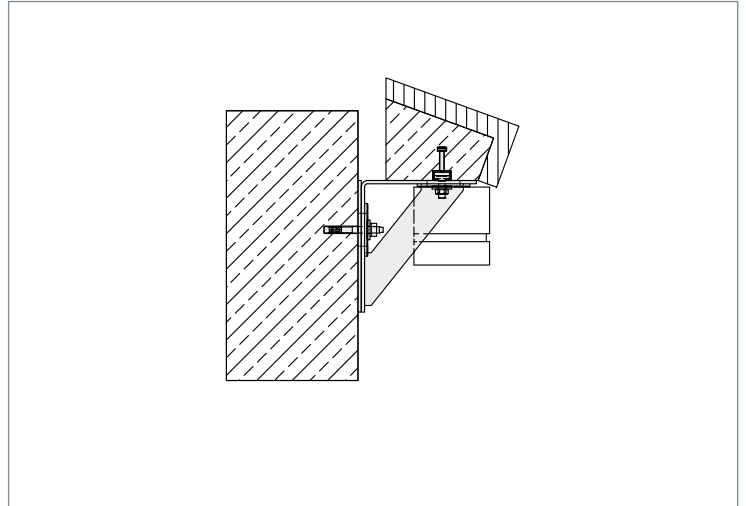

▲ Window sill bracket cantilever with screw connections in CE rail

Use and application

- Dimensioning of special support brackets acc. to structural and constructional requirements.

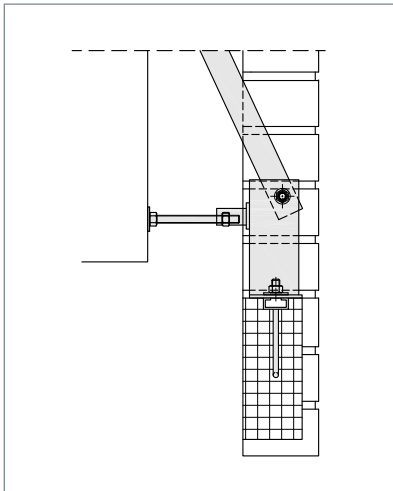

▲ Corner bracket for precast parts FB-ZBV

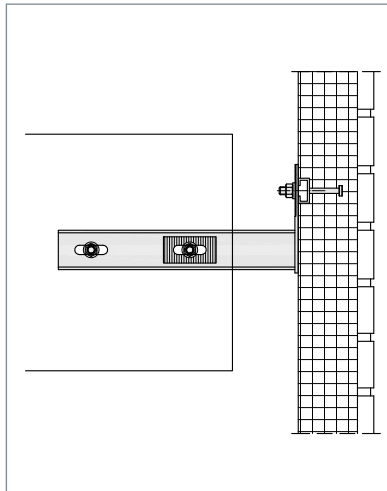

▲ For lateral anchoring

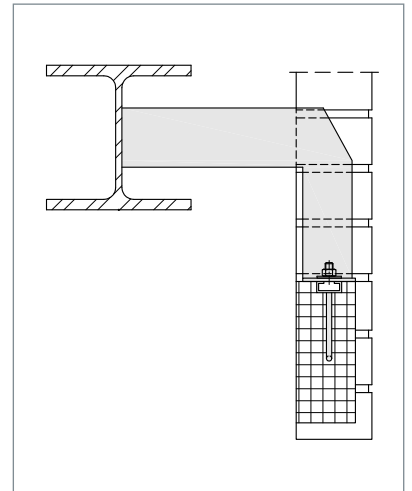

▲ To connect to a steel profile

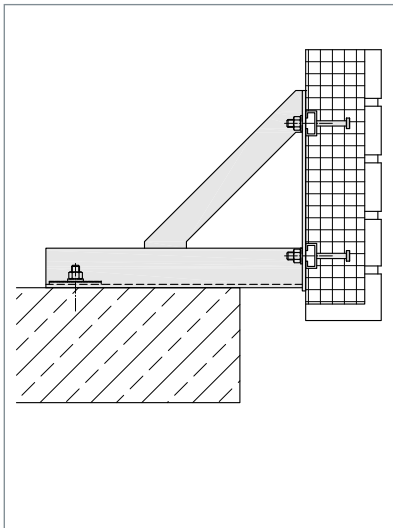

▲ To anchor cornice strips

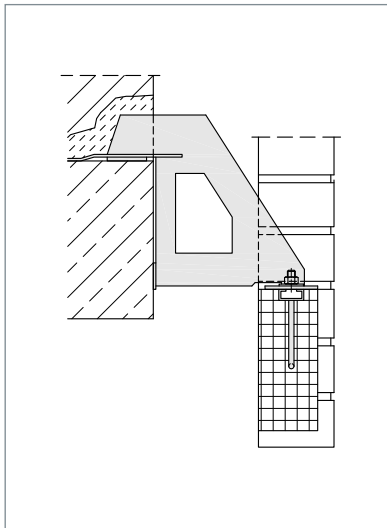

▲ For anchoring behind the precast part

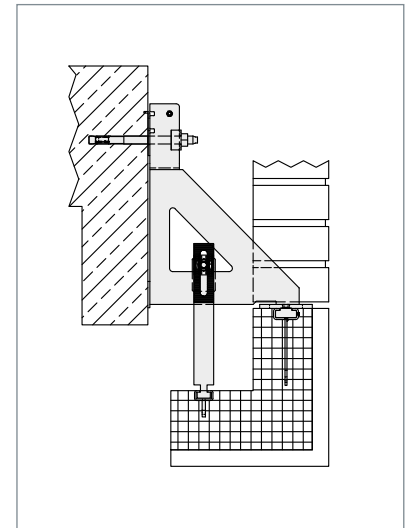

▲ Precast part fixing with anti-tilt device (ZK bracket) on standard FB-U bracket

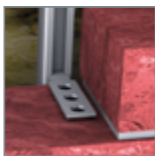
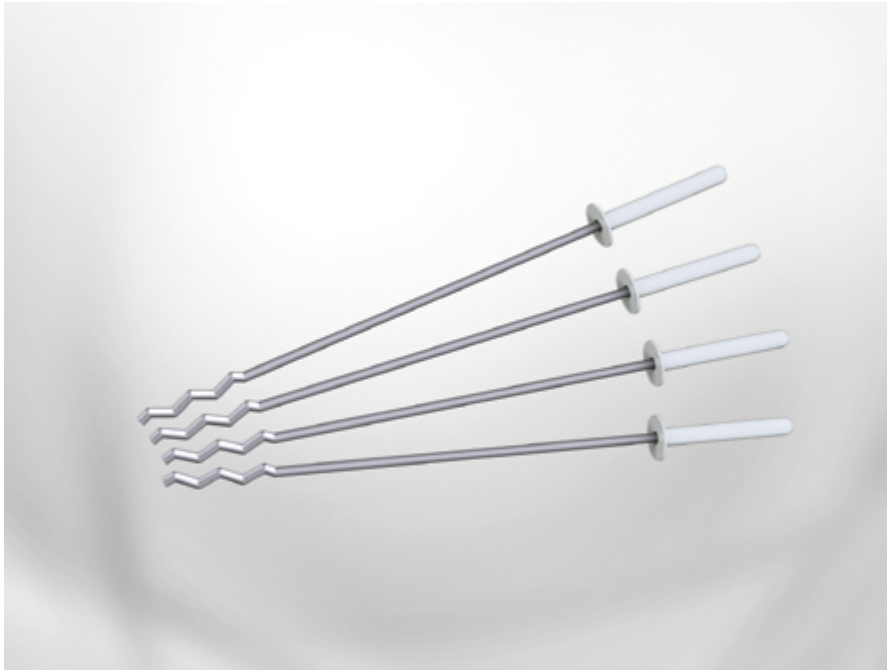

HV-WP

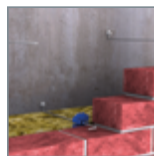

HV-L

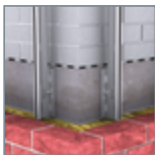

HV-A



HV-S

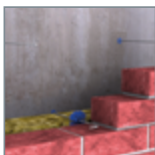

HV-D

MOSO® Wall ties



MOSO® wind post anchor HV-WP is used to hold the facing layer horizontally. It is always used when a design with conventional horizontal connectors is not possible due to an unsound fastening substrate.

Product info

- Wall clearances: 105 mm - 370 mm (> on request)
- Material: stainless steel
corrosion resistance class (CRC) I-V
- Validation: structural calculation

Use and application

- Use as a vertical bridge element
- In combination with the brick tie anchor MA-A-85-A4
- Install wind post anchors at intervals of $a_k \leq 75$ cm according to wind load



▲ Anchoring with MOSO® wind post anchor HV-WP

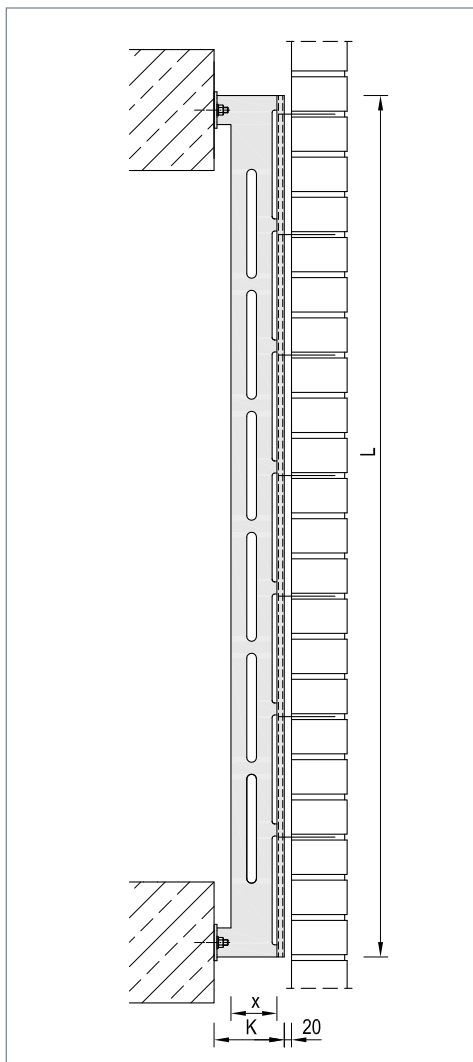

▲ Wind post anchor HV-WP

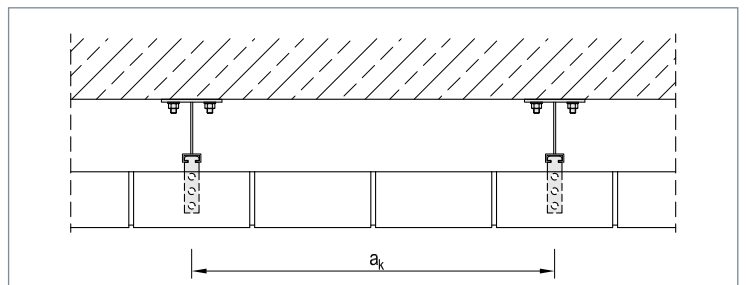

▲ Wind post anchors at variable intervals a_k

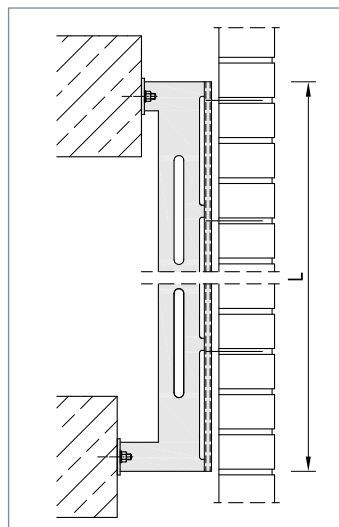

▲ Wind post anchor HV-WPS with different cantilever lengths

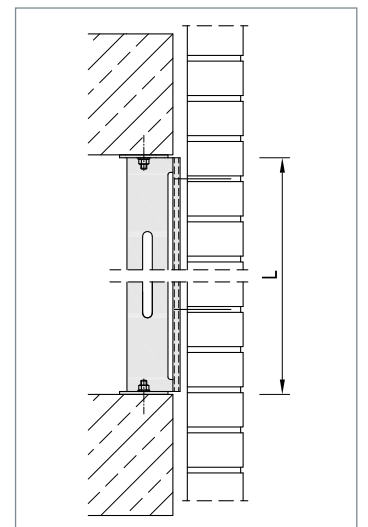

▲ Wind post anchor HV-WPS between reinforced concrete ceilings

Technical data / measurement chart



HV-WP

Type / Variant	Length L [mm]	x [mm]	min. cantilever length K [mm]	Qty. brick tie anchors MA-A-85-A4
	2500	65	85	10
	2750	75	95	11
	3000	75	95	12
	3250	85	105	13
	3500	90	100	14
	3750	95	115	15
	4000	100	120	16
Mounting size	M12			
Recommended fixing ①	Dowels	FAZ II 12/10 A4 Edge clearance $a_r \geq 80$ mm		
	Anchor channels	MBA-CE 38/17 with MHK 38/17 M12x40 A4 Edge clearance $a_r \geq 75$ mm		

① The stated edge clearances are benchmarks. The anchoring should be validated in consideration of the relevant installation situation.

Anchor spacing for wind post anchors acc. to DIN EN 1996-2/NA:2012-01

Wind zone	Velocity pressure q_p and anchor spacing a_k ② for a building height of h					
	q_p [kN/m ²]	a_k [cm]	q_p [kN/m ²]	a_k [cm]	q_p [kN/m ²]	a_k [cm]
	h ≤ 10 m		h > 10 m up to ≤ 18 m		h > 18 m up to ≤ 25 m	
1 Inland	0.50	75	0.65	75	0.75	65
2 Inland	0.65	75	0.80	62.5	0.90	55
Baltic Sea coast and islands ③	0.85	57.5	1.00	50	1.10	45
3 Inland	0.80	62.5	0.95	52.5	1.10	45
Baltic Sea coast and islands ③	1.05	45	1.20	40	1.30	37.5
4 Inland	0.95	52.5	1.15	42.5	1.30	37.5
Baltic Sea coast and islands, North Sea coast ③	1.25	40	1.40	35	1.55	30
North Sea islands	1.40	35	④	④	④	④

② For the dimension a_k , a design load of 0.75 kN/m was applied for the wind post anchor.

③ Coastal regions include strips running parallel with the coast and reaching 5 km inland.

④ On the North Sea islands, the simplified velocity pressure is only applied to buildings which are up to 10 m high.

Example order: HV - WP - 250 - 3000



▲ Fixing in the brickwork with MOSO® wall anchor MA-A

Tender text

Delivery and professional installation of ... pieces of MOSO® wind post anchor type HV-WP-180¹⁾-2500²⁾, incl. dowels for cracked concrete and 10³⁾ pieces of brick tie anchor type MA-A-85-A4.

¹⁾ Cantilever length K

²⁾ Length L acc. to table

³⁾ Quantity acc. to table

Cross-reference for additional information

Pages	Topic
79 - 91	Technical details



Brackets for fascia facing

The MOSO® horizontal connection HV-A is the parapet retaining anchor for crack-free separation of the horizontal securing of the facing shell, e.g. in the case of shell masonry separated by sliding bearings.

But this anchor can also be planned where no shell construction is available for conventional air layer anchors.

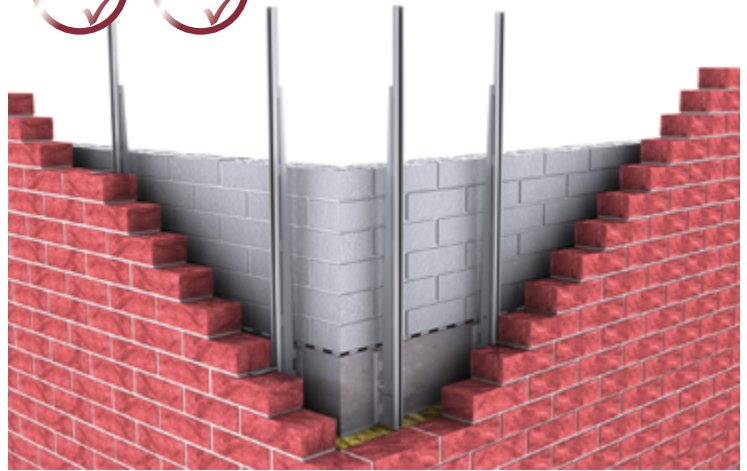

▲ Fascia anchoring with MOSO® horizontal connection HV-A

Product info

- Length: 600 mm - 1100 mm
- Wall clearances: 80 mm - 200 mm (> on request)
- Material: stainless steel
corrosion resistance class (CRC) I-V
- Validation: structural calculation

Use and application

- For horizontal connection in the fascia area
- Anchor spacing $a_k \leq 75 \text{ cm}$ ($\leq 37.5 \text{ cm}$ on the periphery) according to wind load

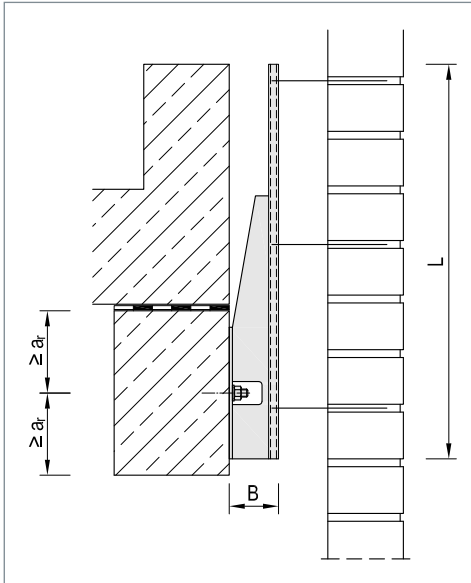

▲ MOSO® horizontal connection HV-A

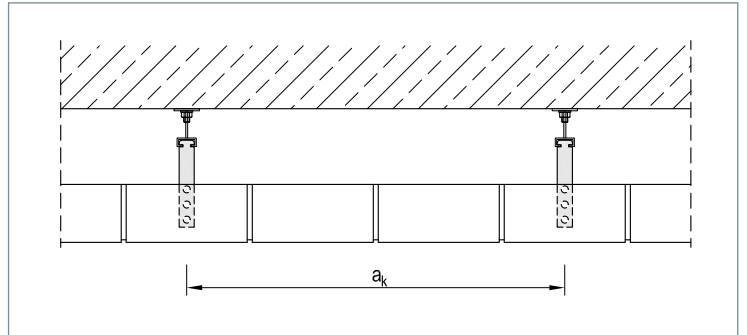

▲ Horizontal connection HV-A

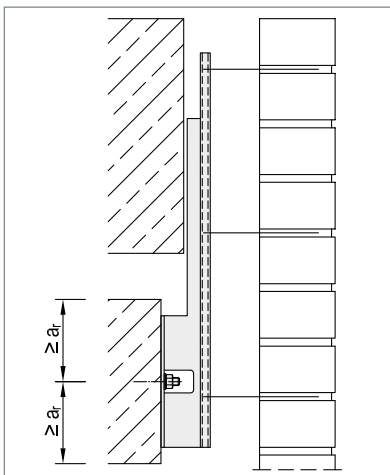

▲ HV-AS, special solution

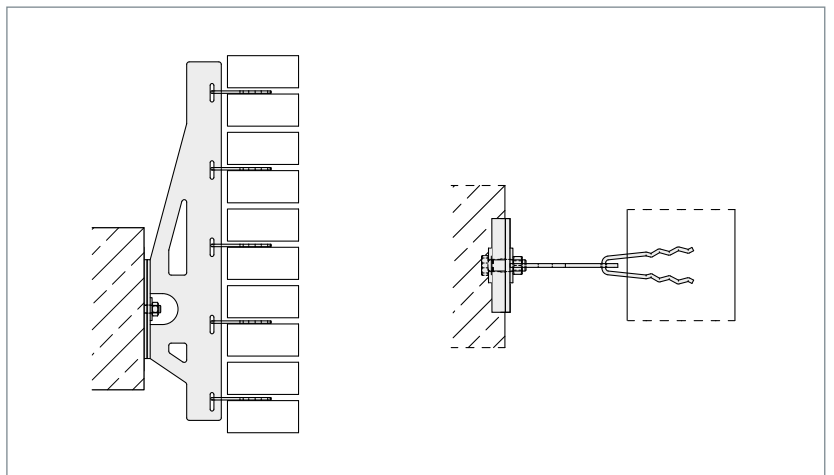

▲ HV-AS Solution without MOS channel

▲ With special air layer anchor



HV-A

Type / Design	Length L [mm]	600	850	1100
	Wall clearance ① [mm]	Brick tie anchor	Brick tie anchor	Brick tie anchor
	80 - 110	3 x MA-A-85-A4	4 x MA-A-85-A4	5 x MA-A-85-A4
	90 - 145	3 x MA-A-120-A4	4 x MA-A-120-A4	5 x MA-A-120-A4
	145 - 200	3 x MA-A-180-A4	4 x MA-A-180-A4	5 x MA-A-180-A4
Larger wall clearances on request				
Width [mm]	B	75	75	75
Mounting size		M10 / M12	M12	M12
Recommended fixing ②	Dowels fischer	FAZ II 10/10 A4 Edge clearance $a_r \geq 100$ mm	FAZ II 12/30 A4 Edge clearance $a_r \geq 75$ mm	RG M12x160 A4 with RSB12 Edge clearance $a_r \geq 100$ mm
	Dowels Hilti	HST3-R M12x165 90/70 Edge clearance $a_r \geq 80$ mm	HAS-U A4 M12x200 mit HVU2 Edge clearance $a_r \geq 140$ mm	HAS-U A4 M16x260 mit HVU2 Edge clearance $a_r \geq 140$ mm
	Anchor channels	MBA-CE 28/15 with MHK 28/15 M10x30 Edge clearance $a_r \geq 100$ mm	MBA-CE 38/17 with MHK 38/17 M12x40 Edge clearance $a_r \geq 100$ mm	MBA-CE 38/17 with MHK 38/17 M12x40 Edge clearance $a_r \geq 100$ mm

Example order: HV - A - 600

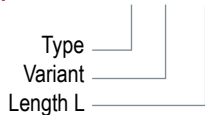

- ① Specifications apply to facing bricks of 115 mm thickness, and a superimposed load of ≤ 2 storeys. Otherwise, support brackets should be adjusted acc. to DIN EN 1996-2/NA.
 ② The stated edge clearances are benchmarks. The anchoring should be validated in consideration of the relevant installation situation.

Possible causes of damage

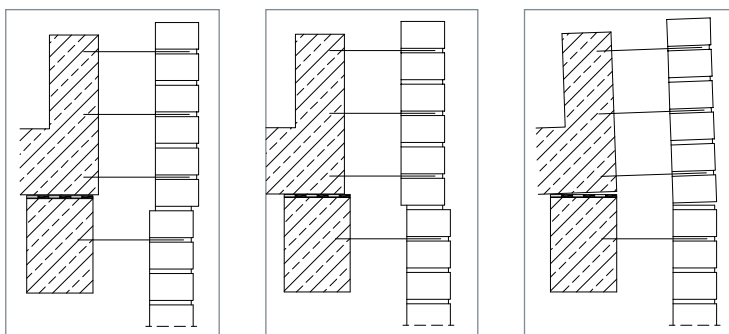

▲ At high temperatures

▲ At low temperatures

▲ Due to torsion

Tender text

Delivery and professional installation of ... pieces of MOSO® horizontal connection type HV-A-850¹⁾, including dowels for cracked concrete²⁾ and brick tie anchors type MA-A-120³⁾.

Alternatively:

Delivery and professional installation of ... m fascia facing with MOSO® horizontal connection type HV-A for a fascia height of ... m, wall clearance (insulation and air layer) of ... cm, facing brick thickness of ... cm, incl. dowels for cracked concrete²⁾ and brick tie anchors required.

¹⁾ Type acc. to table

²⁾ Fixing for in-situ concrete acc. to table

³⁾ Brick-tie anchor acc. to table

Note:

If fixed with hammerhead bolts, the associated support anchor channel should be put out for a separate tender.

Cross-reference for additional information

Pages	Topic
79 - 91	Technical details



Wire anchors for subsequent fastening

The MOSO® horizontal connection HV-D is the wire anchor for the subsequent connection of double-shell masonry according to DIN EN 1996-2/NA.

Due to different designs, the anchors can be placed in different anchoring grounds.

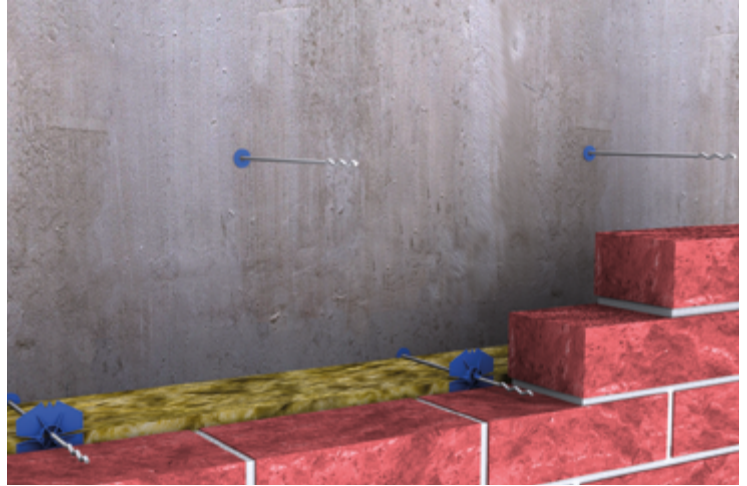

▲ Anchoring with MOSO® horizontal connection HV-DAZ

Product info

- Diameter: 4 / 5 mm
- Wall clearances: up to 400 mm (> on request)
- Material: stainless steel
corrosion resistance class (CRC) III-IV*
- Validation: building approval

* Further corrosion resistance classes on request

Use and application

- HV-DAZ: Plug anchors for concrete or solid brick
- HV-DPB: Screw-in anchors for aerated concrete
- HV-DU: Screw-in anchors for wood

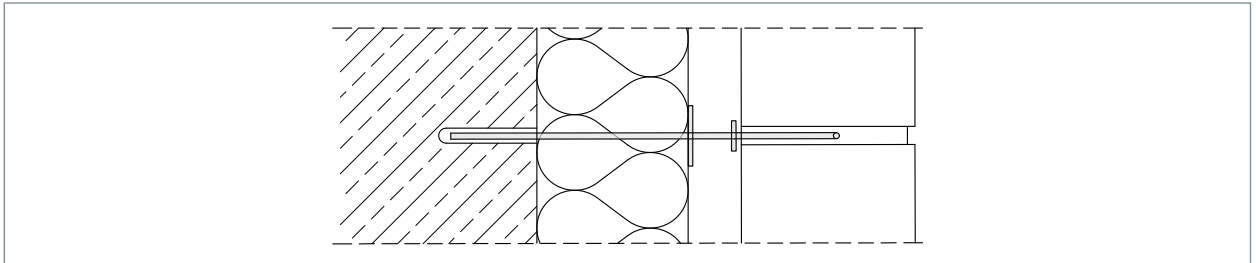

▲ MOSO® horizontal connection HV-DAZ

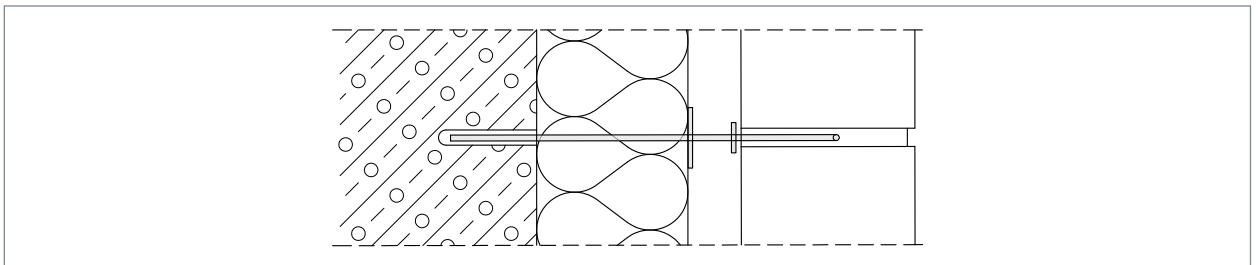

▲ MOSO® horizontal connection HV-DPB

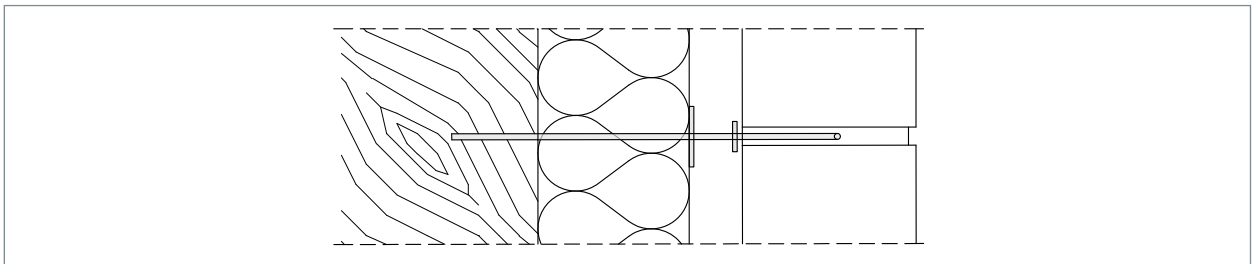

▲ MOSO® horizontal connection HV-DU

Technical data / measurement chart



HV-DAZ

Type / Design	Dimensions [mm]	max. gap between walls [mm]	Hole [mm]	Nachweis
HV-DAZ  Anchoring base KS solid stone or concrete	4x180	45	8x60	Building approval
	4x210	75		
	4x250	115		
	4x275	140*		
	4x300	165*		
	4x320	185*		
	4x350	215*		
	4x375	240*		
	4x400	250		
	5x350	bis 215 mm	8x60	Building approval up to 40 cm
	5x375	bis 240 mm		
	5x400	bis 265 mm		
	5x425	bis 290 mm		
	5x450	bis 315 mm		
	5x475	bis 340 mm		
	5x500	bis 365 mm		
	5x525	bis 390 mm		
	5x550	bis 415 mm		

Alternatively also available as HV-DPB for rigid foam insulation and HV-DU for load-bearing timber constructions.

* also available in CRC IV from stock

Other types and lengths on request.

Example order: HV - DU - 4x210

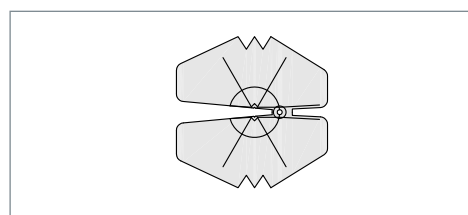
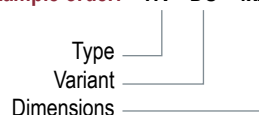

▲ Accessories: Iso clip

Accessories

Description	for variant
Claw plates Ø 60 mm	-DAZ, -DPB, -DU
Drip plate Ø 25 mm	-DAZ, -DPB, -DU
ISO clip Ø 60 mm	-DAZ, -DPB, -DU
Screw-in adapter	-DPB, -DU

Tender text

Delivery and professional installation of ... pieces of MOSO® horizontal connection type HV-DAZ¹⁾-4x275²⁾, including ISO clip.

Alternatively:

Delivery and professional installation of ... m² wall surface with MOSO® horizontal connection type HV-DAZ¹⁾ for a wall clearance (insulation and air layer) of ... cm, facing brick thickness of ... cm, incl. insulation holder.

¹⁾ Type acc. to table

²⁾ Dimensions acc. to table

Cross-reference for additional information

Pages	Topic
84 - 85	Technical specifications for masonry support DIN EN 1996-2/NA



Air layer eyelet anchor for subsequent fastening

HV-L

Wall ties

The MOSO® horizontal connection HV-L is the air layer eye anchor for connecting two-shell masonry.

During renovation, demolition of the old facing layer can be dispensed with, as the anchoring can be carried out through the old layer.

This anchor can also be used in difficult anchoring situations if the load-bearing capacity is proven by tensile tests.

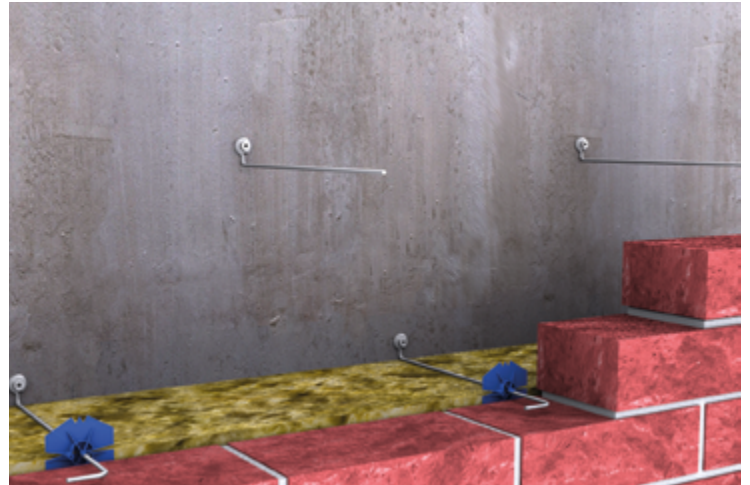

▲ Anchoring with MOSO® horizontal connection HV-L

Product info

- Diameter: 4 mm
- Wall clearances: up to 150 mm (> on request)
- Material: stainless steel
corrosion resistance class (CRC) III-IV
- Validation: building approval
for frame anchors

Use and application

- For restoration projects aiming to preserve the old facing shell
- For subsequent fixing in perforated brick

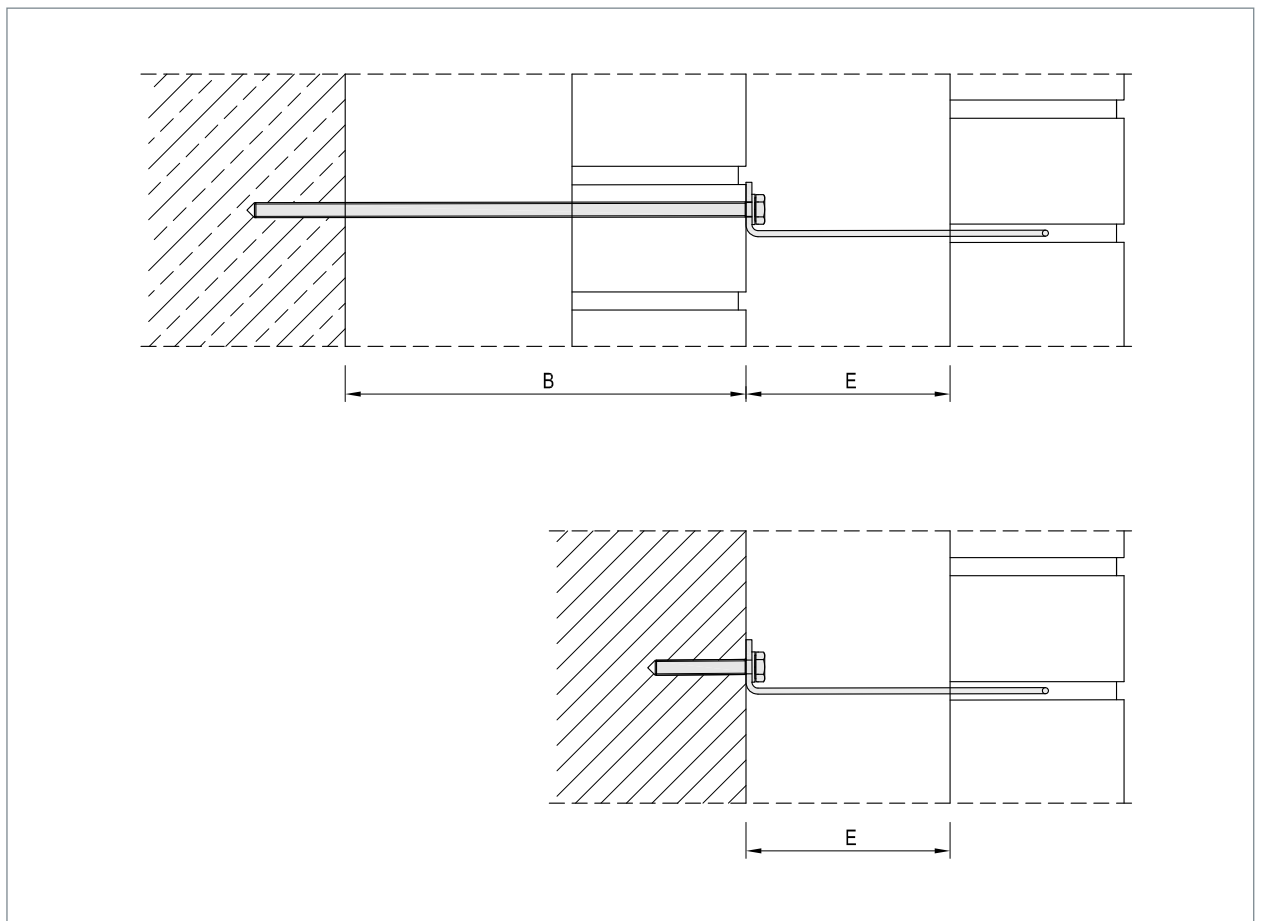

▲ MOSO® horizontal connection HV-L, anchoring in perforated brick possible

Technical data / measurement chart



HV-L

Type / Design	Description ①	max. fixing thickness B [mm]	Anchoring base
HV-L 	HV-L-10-235	10	Solid brick Perforated brick
	HV-L-30-235	30	
	HV-L-50-235	50	
	HV-L-70-235	70	
	HV-L-90-235	90	
	HV-L-110-235	110	
	HV-L-130-235	130	
	HV-L-150-235	150	
	HV-L-180-235	180	
HV-L-210-235	210		

① Applies to a wall clearance E of up to 150 mm. Further dimensions on request.

Example order: HV - L - 10 - 235

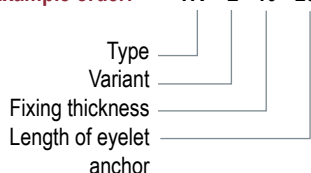

Installation HV-L

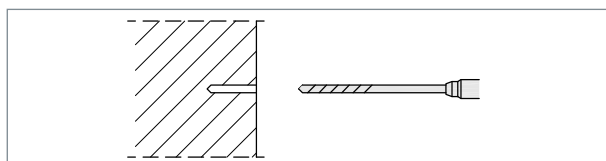

▲ Step 1: Drill and clean a hole.

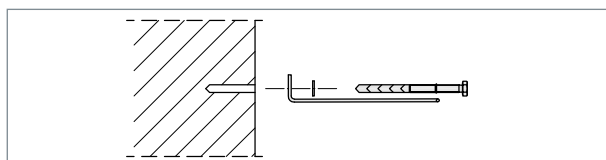

▲ Step 2: Pull eyelet anchor and washer over the dowel casing from the back.

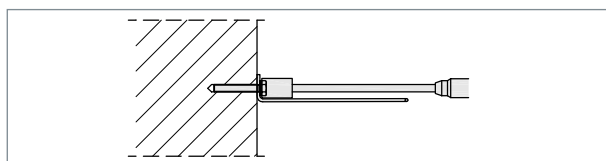

▲ Step 3: Screw in MOSO® horizontal connection HV-L.

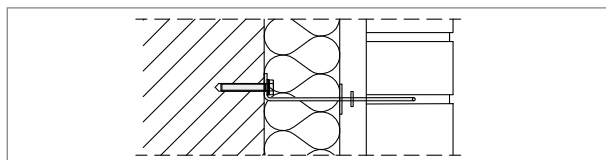

▲ Step 4: Fit holder for insulation and drip plates if required.

Accessories

Description
Claw plates Ø 60 mm
Drip plate Ø 25 mm
ISO clip Ø 60 mm

Tender text

Delivery and professional installation of ... pieces of MOSO® horizontal connection type V-L-10-235¹⁾, including ISO clip.

Alternatively:
 Delivery and professional installation of ... m² wall surface with MOSO® horizontal connection type HV-L for wall construction: old insulation and air space ... cm, old facing brick thickness ... cm, new insulation and wall space ... cm, new facing brick thickness ... cm, including insulation holders.

¹⁾ Type acc. to table

Cross-reference for additional information

Pages	Topic
82	Fixing facade dowels
84 - 85	Technical specifications for masonry support DIN EN 1996-2/NA



Customised MOSO® horizontal connections HV-S in special design are individually calculated by our engineering office to ensure optimum solutions even in difficult conditions.

Product info

- Load stages: as required
- Wall clearances: as required
- Material: stainless steel
corrosion resistance class (CRC) III-IV
- Validation: structural calculation

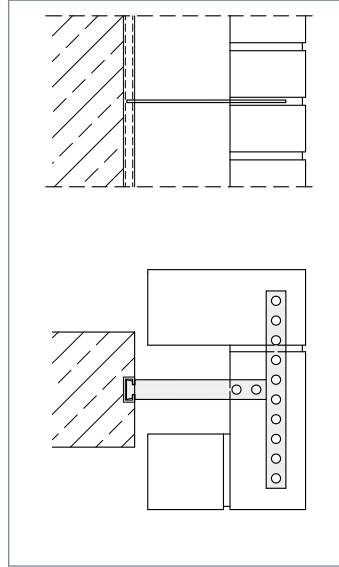

▲ For pillar anchoring

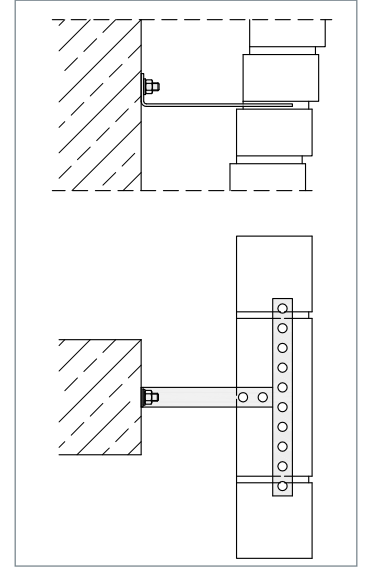

▲ For stepped brickwork

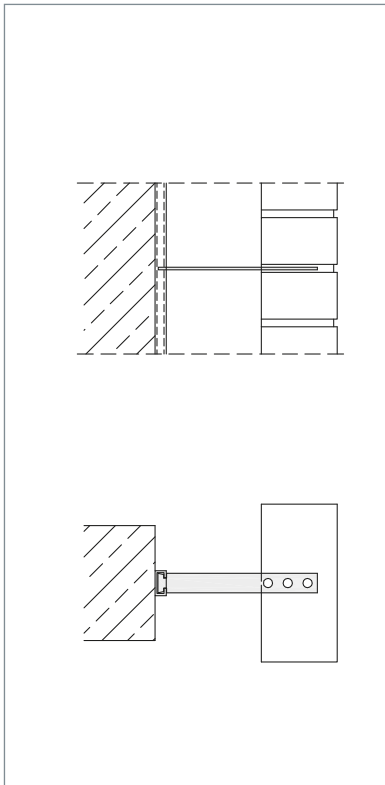

▲ To connect to a channel

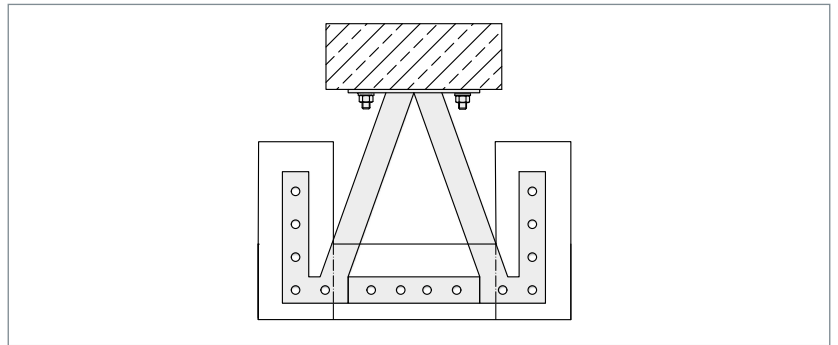

▲ Horizontal securing of a U-shaped masonry pier

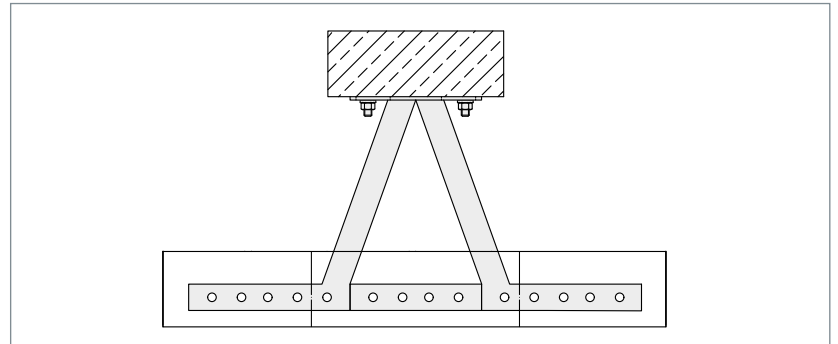

▲ Horizontal securing of a long masonry pier with a narrow reinforced concrete support in the carcass as anchoring base

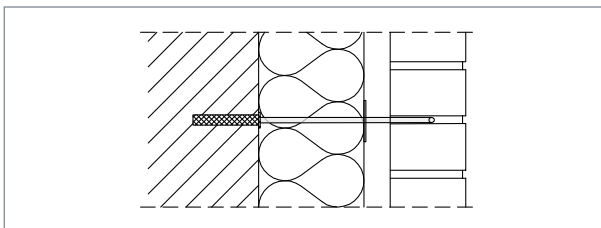

▲ For difficult anchoring ground

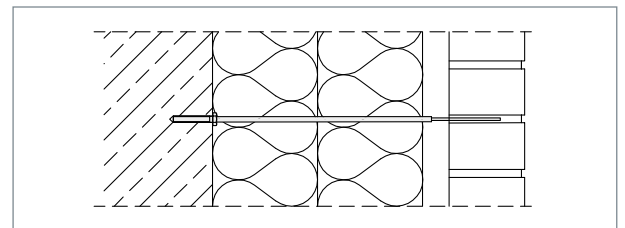

▲ For large shell distances



GA-Q

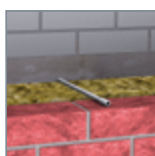

GA-Z



GA-S

MOSO® Scaffold anchors



In Germany, scaffolds must be anchored according to DIN 4420-3:2006-01 or DIN 4426:2017-01. The load-bearing capacity of the MOSO® scaffold anchors GA-Q and GA-Z are calculated according to the specifications of DIN 4426:2017-01, as the loads to be anchored are unfavourable here.

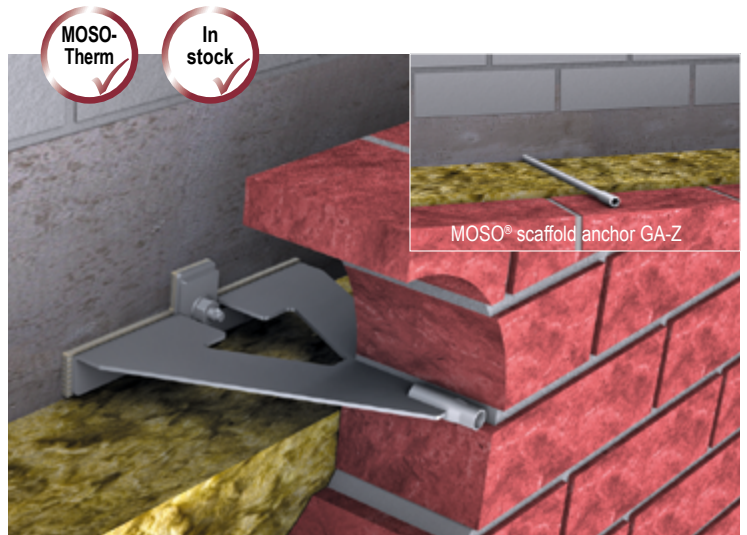

▲ Anchoring with MOSO® scaffold anchor GA-Q, also available with MOSOTherm

Product info

- Load stages: 5.7 kN
- Wall clearances: 15 mm - 260 mm (> on request)
- Material: stainless steel
corrosion resistance class (CRC) I-V
- Validation: structural calculation

Use and application

- Type GA-Q for tensile and lateral forces
- Type GA-Z only for tensile forces

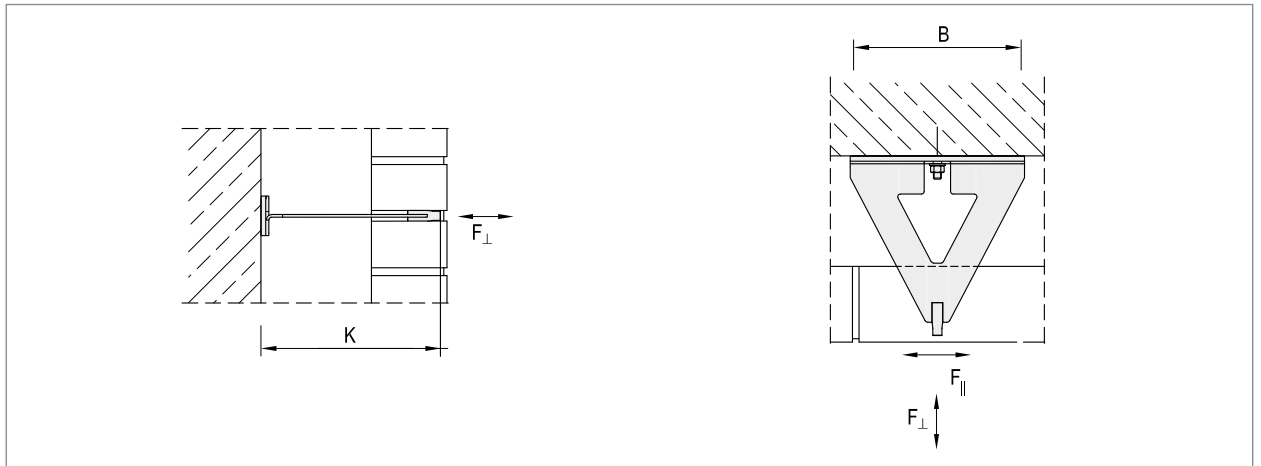

▲ MOSO® scaffold anchor GA-Q

▲ GA-Q

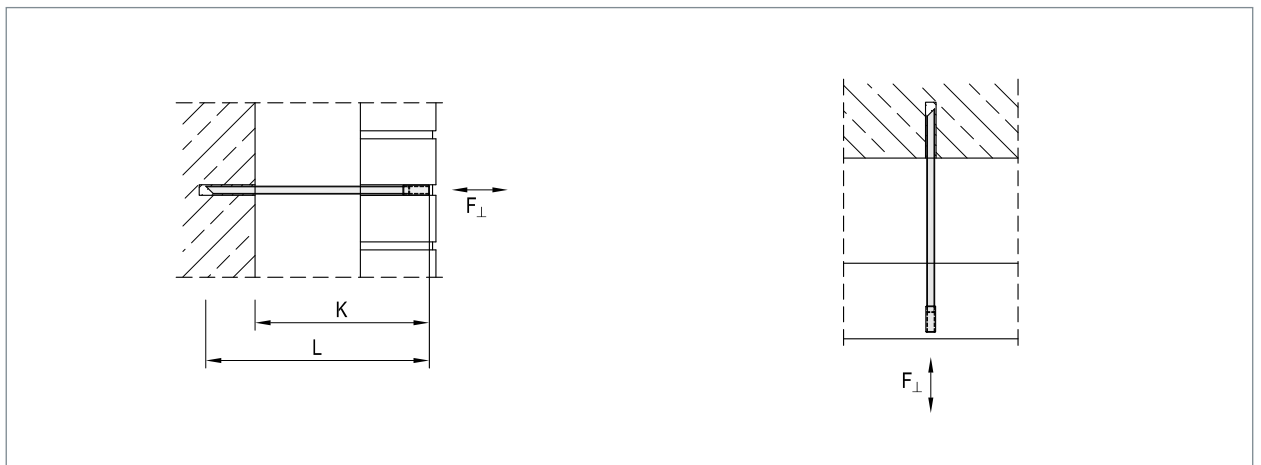

▲ MOSO® scaffold anchor GA-Z

▲ GA-Z

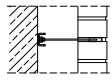
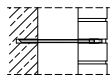

GA-Q / GA-Z

Type / Design	Load stage	5.7 kN			
	Wall clearance ① [mm]	Cantilever length K [mm]	GA-Q (width W) [mm]	GA-Z (length L) [mm]	
GA-Q 	15 - 40	125		200	
	35 - 60	145		220	
	55 - 80	165		240	
	75 - 100	185	185	260	
	95 - 120	205	205	280	
	115 - 140	225	225	300	
GA-Z 	135 - 160	245	245	320	
	155 - 180	265	265	340	
	175 - 200	285	285	360	
	195 - 220	305	305	380	
	215 - 240	325	325	400	
	235 - 260	345	345	420	
	Larger wall clearances on request				
	Lifting screw to be used			M12	M12
Protective plug			grey Ø20 mm	grey Ø20 mm	
Mounting size			M12	M12	
Recommended fixing ②			RG M12x160 A4 with RSB12	RSB12 mini	

① Specifications apply to facing bricks of 115 mm thickness

② The anchoring should be validated in consideration of the relevant installation situation.

Example order: GA - Q - 205 - 5.7

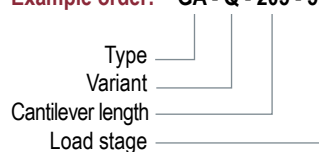

Dimensioning of scaffold anchors

According to DIN 4426:2017-01 (Equipment for building maintenance - Safety requirements for workplaces and accesses - Design and construction), the vertical spacing between the anchoring levels must not exceed 4 m - the horizontal spacing is not specified. This standard does not differentiate between covered and uncovered scaffolds. The following loads are applied vertically and parallel for each metre of scaffolding length:

$$F_{\perp} = 2.25 \text{ kN/m}$$

$$F_{\parallel} = 0.75 \text{ kN/m}$$

At a typical scaffold support spacing of 2.5 m, this results in the following loads for the MOSO® scaffold anchors:

$$F_{\perp} = 2.25 \text{ kN/m} \times 2.5 \text{ m} = 5.63 \text{ kN}$$

$$F_{\parallel} = 0.75 \text{ kN/m} \times 2.5 \text{ m} = 1.88 \text{ kN}$$

Assuming a partial safety factor γ_Q of 1.5 for variable loads, the following design loads are derived:

$$F_{ED, \perp} = 5.63 \text{ kN} \times 1.5 = 8.45 \text{ kN}$$

$$F_{ED, \parallel} = 1.88 \text{ kN} \times 1.5 = 2.82 \text{ kN}$$

If the vertical spacing is less than 4 m, linear reduction of the forces is permissible. The stated forces should be doubled at the edges of the building (e.g. eaves, corners of the building).

Cross-reference for additional information

Pages	Topic
80 - 83	Technical details

Tender text

Delivery and professional installation of ... pieces of MOSO® scaffold anchor type GA-Q-185¹⁾-5,7²⁾, incl. protective plugs and dowels for cracked concrete³⁾.

¹⁾ Cantilever length acc. to table

²⁾ Load stage acc. to table

³⁾ Fixing acc. to table



The MOSO® scaffold anchors GA-S in special design are individually calculated by our engineering office to ensure optimum solutions even in difficult conditions.

Product info

- Load stages: as required
- Wall clearances: as required
- Material: stainless steel
corrosion resistance class (CRC) I-V
- Validation: structural calculation

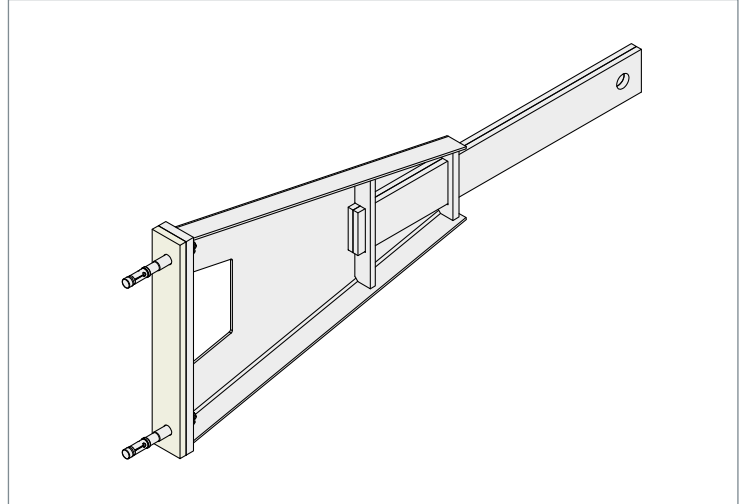

▲ Special permanent scaffolding anchor for large shell spacings

Use and application

- Dimensioning of special support brackets acc. to structural and constructional requirements.

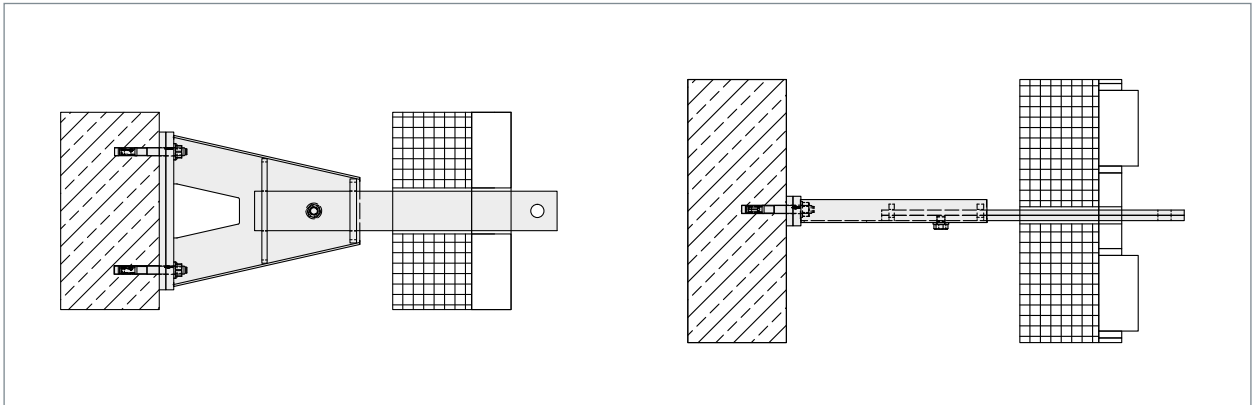

▲ For anchoring in element facades with low horizontal joint thickness

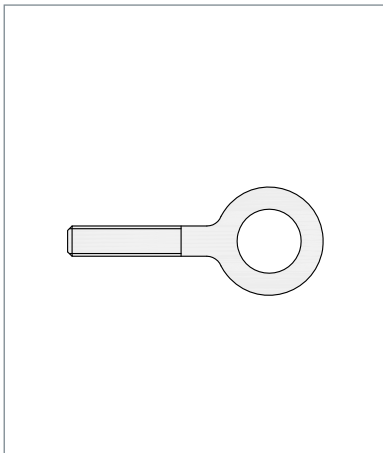

▲ Ring screw M12

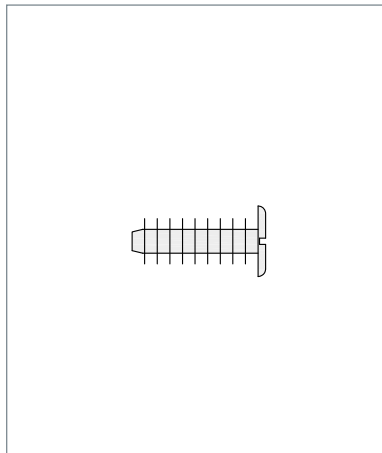

▲ Cover plug standard: in cement-grey

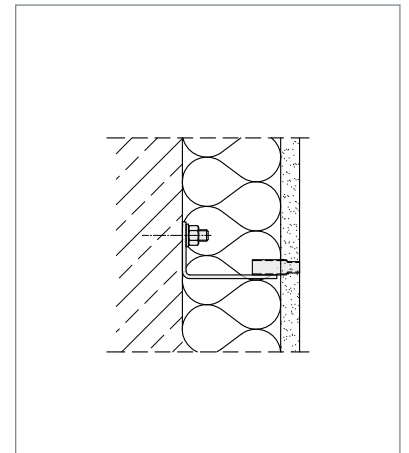

▲ For short distances



FB-G / WK-U



Special solutions



MO-DA



WK-I / FB-I

MOSO® Bracket variants



The U-profile variant is the solution for interception lines that lie above the anchorage point of the support anchor. In addition, this bracket variant can take up eccentric load distributions via a second anchorage point.

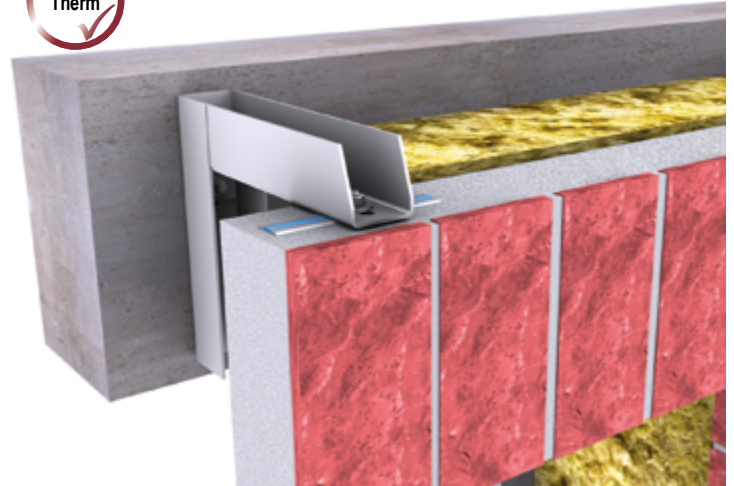

Product info

- Load stages: 3.0 kN - 25.0 kN
- Wall clearances: 20 mm - 370 mm (> on request)
- Height adjustment: ± 15 mm
- Material: stainless steel
corrosion resistance class (CRC) I-V
- Validation: structural calculation

▲ U-profile brackets as gallows version

Use and application

- with low component height
- in the area of e.g. roller shutters
- for high-level interception situations

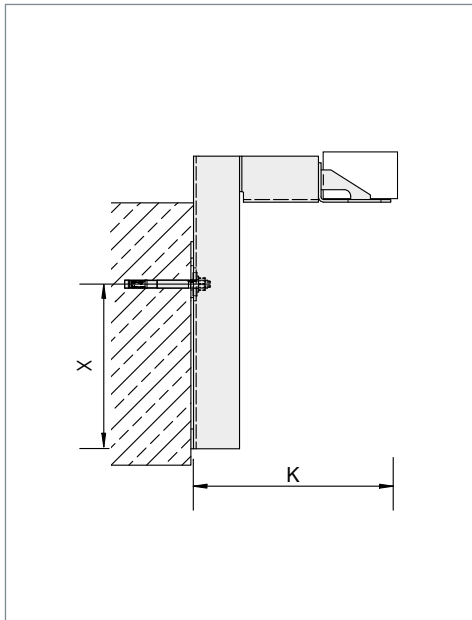

▲ MOSO® angle bracket anchor WK-U

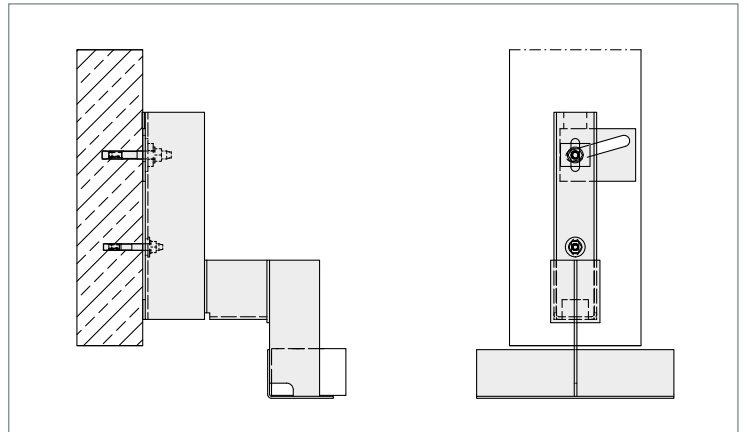

▲ Single anchor mounting on narrow carcass, 2nd anchor as anti-rotation device

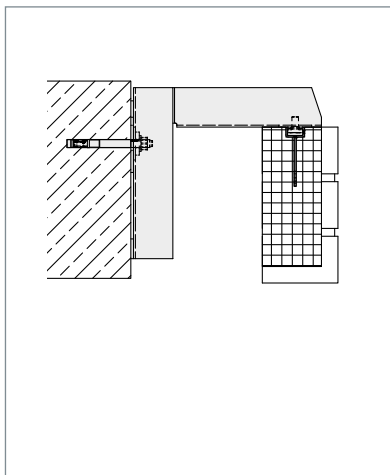

▲ FB-G

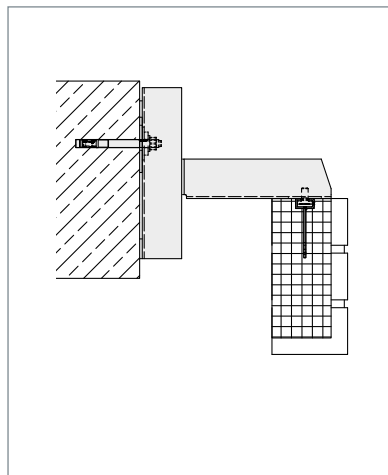

▲ FB-G, central elevation

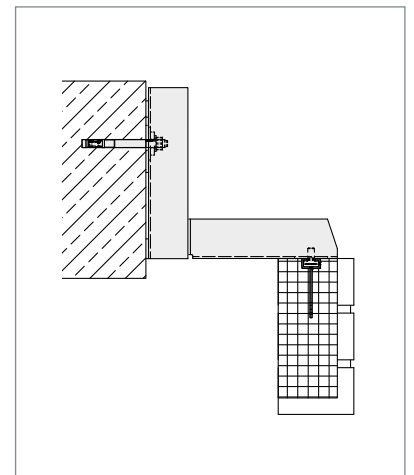

▲ FB-G, elevation below



U-profile-brackets

Type / Version	Load level	3.0 kN			6.0 kN			9.0 kN		
	Wall distance W up to max. [mm]	Cantilever length K [mm]	Bracket height x [mm]	U-profile	Cantilever length K [mm]	Bracket height x [mm]	U-profile	Cantilever length K [mm]	Bracket height x [mm]	U-profile
FB- 	100	190 mm	150 mm	U56/50/3	190 mm	200 mm	U56/70/3	190 mm	250 mm	U56/80/3
	110	200 mm	150 mm	U56/50/3	200 mm	200 mm	U56/70/3	200 mm	250 mm	U56/80/3
	120	210 mm	150 mm	U56/60/3	210 mm	200 mm	U56/70/3	210 mm	250 mm	U56/80/3
	160	250 mm	175 mm	U56/60/3	250 mm	250 mm	U56/80/3	250 mm	300 mm	U65/80/4
	170	260 mm	175 mm	U56/70/3	260 mm	250 mm	U56/80/3	260 mm	300 mm	U65/80/4
	200	290 mm	175 mm	U56/70/3	290 mm	250 mm	U56/80/3	290 mm	300 mm	U65/90/4
	210	300 mm	175 mm	U56/70/3	300 mm	300 mm	U65/80/4	300 mm	300 mm	U65/90/4
	240	330 mm	175 mm	U56/70/3	330 mm	300 mm	U65/80/4	330 mm	350 mm	U65/100/4
	250	340 mm	200 mm	U56/70/3	340 mm	350 mm	U65/90/4	340 mm	350 mm	U65/100/4
	280	370 mm	200 mm	U56/70/3	370 mm	350 mm	U65/90/4	370 mm	400 mm	U65/100/4
	290	380 mm	200 mm	U56/70/3	380 mm	350 mm	U65/90/4	380 mm	400 mm	U65/100/4
	320	410 mm	250 mm	U56/80/3	410 mm	350 mm	U65/90/4	410 mm	425 mm	U71/100/5
	330	420 mm	300 mm	U65/80/3	420 mm	350 mm	U65/90/4	420 mm	450 mm	U71/110/5
340	430 mm	300 mm	U65/80/3	430 mm	400 mm	U65/100/4	430 mm	450 mm	U71/110/5	
360	450 mm	350 mm	U65/80/3	450 mm	400 mm	U65/100/4	450 mm	450 mm	U71/110/5	

Type / Version	Load level	4.0 kN			8.0 kN			12.0 kN		
	Wall distance W up to max. [mm]	Cantilever length K [mm]	Bracket height x [mm]	U-profile	Cantilever length K [mm]	Bracket height x [mm]	U-profile	Cantilever length K [mm]	Bracket height x [mm]	U-profile
WK- 	100	190 mm	150 mm	U56/60/3	190 mm	200 mm	U56/70/3	190 mm	250 mm	U65/80/4
	120	210 mm	150 mm	U56/60/3	210 mm	200 mm	U56/80/3	210 mm	250 mm	U65/80/4
	160	250 mm	175 mm	U56/70/3	250 mm	250 mm	U65/90/4	250 mm	300 mm	U65/90/4
	170	260 mm	175 mm	U56/80/3	260 mm	250 mm	U65/90/4	260 mm	300 mm	U65/90/4
	200	290 mm	175 mm	U56/80/3	290 mm	250 mm	U65/90/4	290 mm	300 mm	U71/100/5
	210	300 mm	175 mm	U56/80/3	300 mm	300 mm	U65/90/4	300 mm	300 mm	U71/100/5
	240	330 mm	175 mm	U56/80/3	330 mm	300 mm	U65/90/4	330 mm	350 mm	U71/100/5
	250	340 mm	200 mm	U56/80/3	340 mm	350 mm	U65/100/4	340 mm	350 mm	U71/100/5
	280	370 mm	200 mm	U56/80/3	370 mm	350 mm	U65/100/4	370 mm	400 mm	U71/110/5
	290	380 mm	200 mm	U56/80/3	380 mm	350 mm	U65/100/4	380 mm	400 mm	U71/110/5
	320	410 mm	250 mm	U65/80/4	410 mm	350 mm	U65/100/4	410 mm	425 mm	U71/110/5
	330	420 mm	300 mm	U65/80/4	420 mm	350 mm	U65/100/4	420 mm	450 mm	on request
	340	430 mm	300 mm	U65/80/4	430 mm	400 mm	U71/100/5	430 mm	450 mm	on request
360	450 mm	350 mm	U65/80/4	450 mm	400 mm	U71/100/5	450 mm	450 mm	on request	

Example order: WK - U - 290 - 8,0 - 1250 - 2R

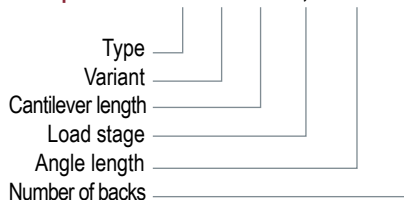

Example order: FB - G - 210 - 3,0

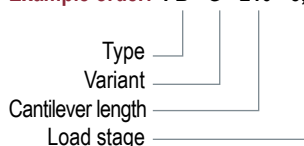

Tender text

Delivery and professional installation of ... pieces of MOSO® angle-bracket anchor type WK-U-290-8,0-1250-2R, incl. dowels for cracked concrete³⁾.

Tender text

Delivery and professional installation of ... pieces of MOSO® precast part fixing FB-G-210-3,0 incl. dowels for cracked concrete³⁾ and type approved fixing for anchor channel MBA 28/15 ES (F) concreted into the precast part⁴⁾.



Ceiling adapter - High load transfer with low component heights MO-DA

The ceiling adapter makes it possible to anchor load steps of up to 8 kN to low component heights. This makes it possible, for example, to anchor floor-by-floor to a reinforced concrete slab even at outside corners. Despite anchoring to the slab, adjustment in height remains possible. In the case of non-concreted overhangs or upstands, this system is a practical solution that is kept in stock at our company. The new optimised version offers a greater load transfer per anchor point and 2.5 cm more static bracket height (x-dimension).

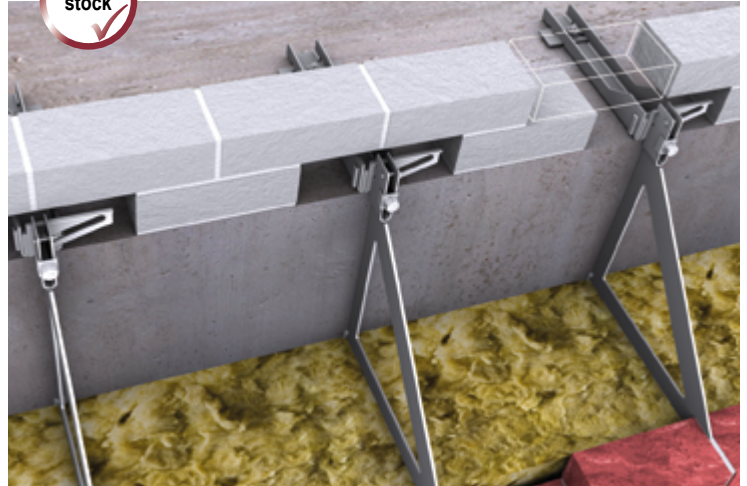

▲ Ceiling adapter MO-DA

Produkt-Info

- Wandabstände: 20 - 360 mm (> on request)
- Material: stainless steel
corrosion resistance class (CRC) I-V
- Validation: structural calculation

Use and application

- if only a reinforced concrete slab is available as an anchoring base
- use in standard not possible with TAK 2 or 3

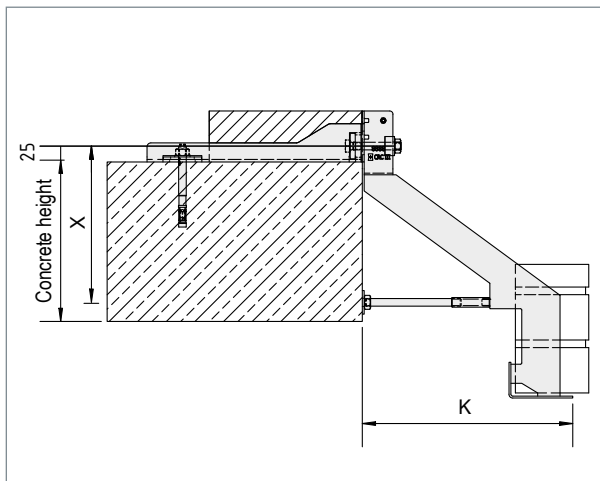

▲ The X-dimension of the bracket is 25 mm higher than the top edge of the reinforced concrete component

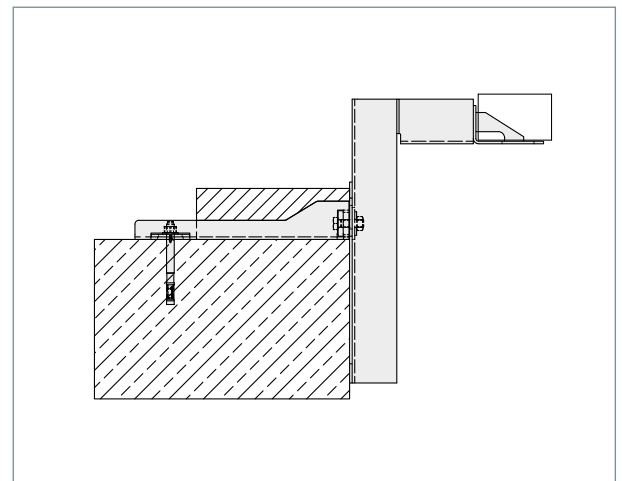

▲ WK-U console to MO-DA

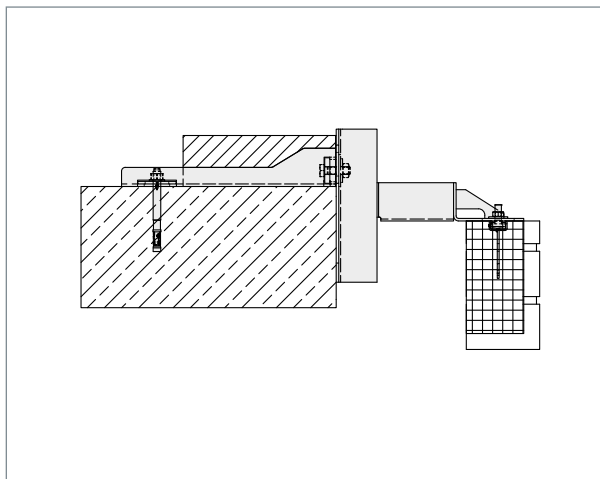

▲ FB-G Konsole to MO-DA

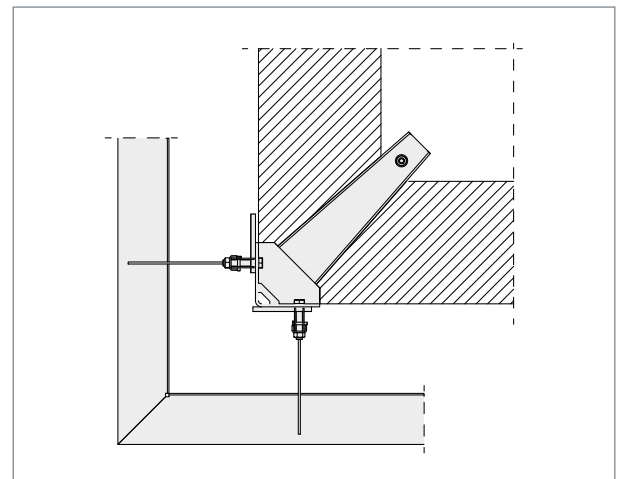

▲ Corner variant

Technical data / measurement chart

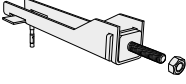

MO-DA

Type / Version	Load stage	4.0 kN	8.0 kN
	Shell distance [mm]	Minimum reinforced concrete component height in mm	
MO-DA 	up to 150	150	200
	up to 160	175	200
	up to 200	175	250
	up to 240	175	300
	up to 280	175	350
	up to 290	200	350
	up to 320	250	350
	up to 340	300	350
	up to 360	350	400

Special brackets with reduced bracket height possible on request. However, the tensile load on the ceiling adapter must not exceed 10kN.

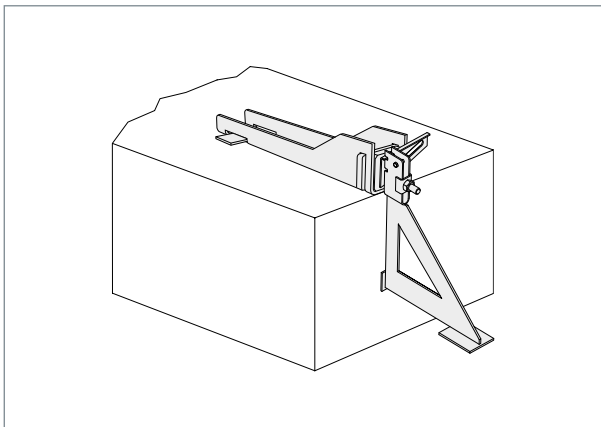
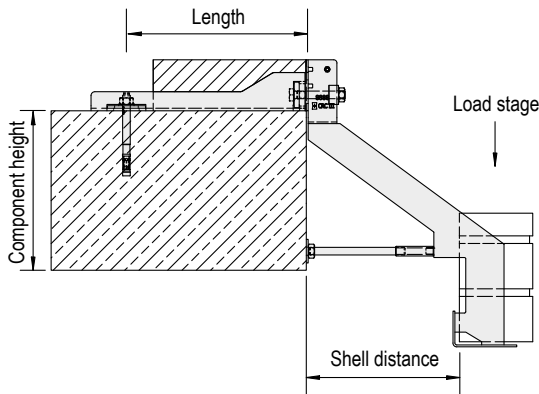

▲ EK-U console combined with MO-DA

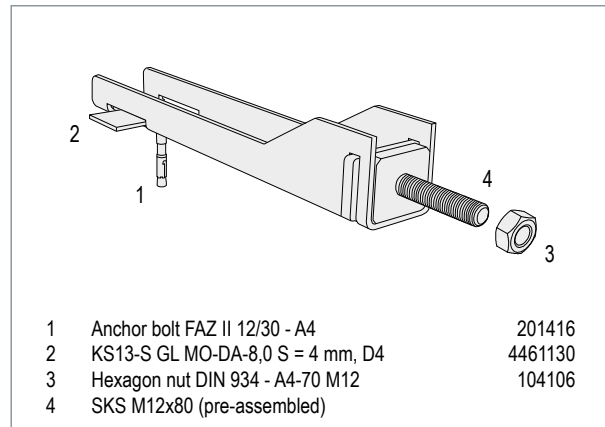

▲ MO-DA accessory

Example order: MO - DA - 280 - 8,0 **Art.-no.** 4989118

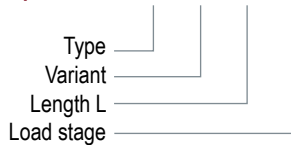

Cross-reference for additional information

Pages	Topic
84 - 85	Technical specifications for masonry support DIN EN 1996-2/NA

Tender text

Delivery and professional installation of ... pieces of MOSO® ceiling adapter MO-DA 280-8,0 for the connection of bracket support on the reinforced concrete slab/sole.

Core drillings or other passages in the structural masonry may be necessary.



This bracket type is designed for installation parallel to the facing, as shown in the diagram under a projecting balcony slab.

In accordance with the low height of the brickwork, the construction is slim to allow installation in confined spaces. The design is available as an angle rail or as a prefabricated fastening.

Product info

- Material: stainless steel
corrosion resistance class (CRC) III/IV (Outdoor area)
- Validation: structural calculation

Please note

- The anchoring to the balcony slab must be clarified.
- The facing surface, which is anchored to the balcony slab, should be separated from the adjoining facing masonry with expansion joints.

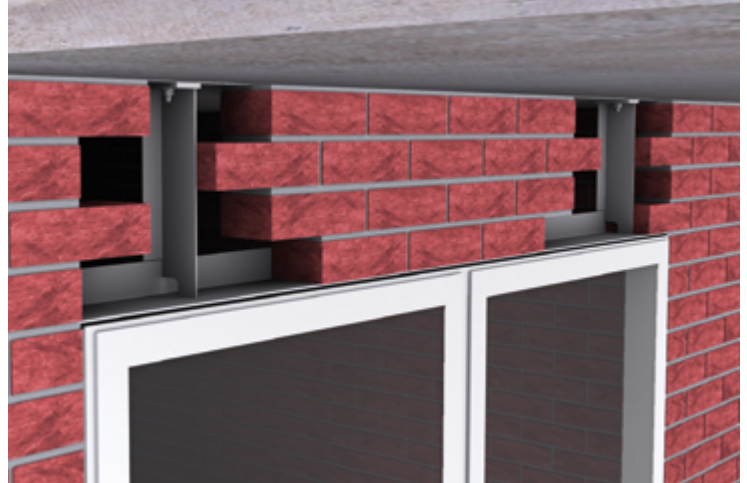

▲ WK-I bracket under balcony slab

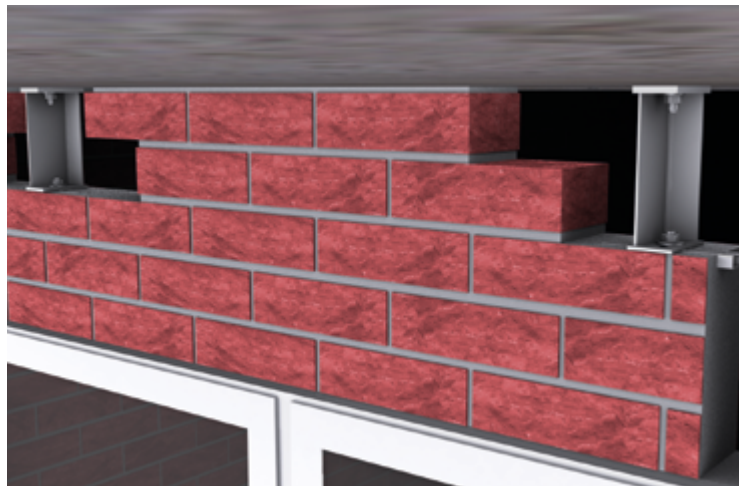

▲ FB-I bracket with precast fixing

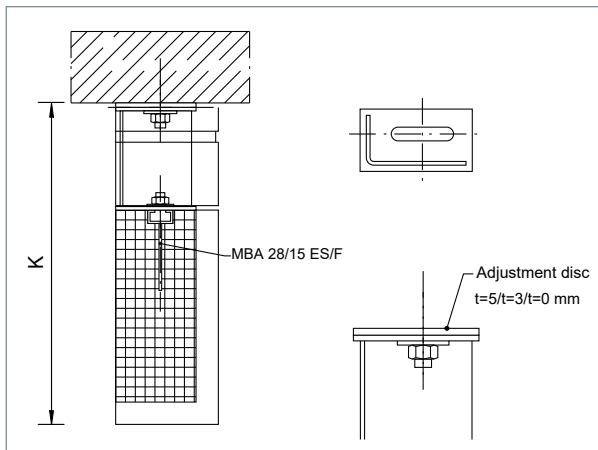

▲ FB-I bracket

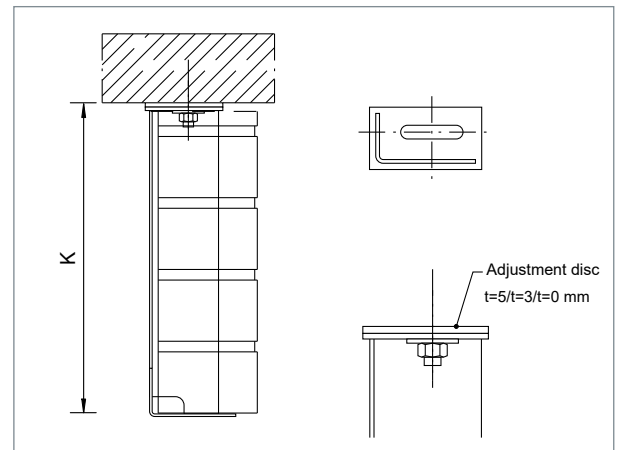

▲ WK-I bracket

Technical data / measurement chart



Load and length ratio

Wall height [m]	Maximum element length [m]
0.24	2.99
0.37	2.36
0.49	1.74

Precast layer heights NF and DF

Precast layers	NF	DF
2 layers	0.154	Height too low
3 layers	0.238	0.177
4 layers	0.321	0.239

Cantilever determination FB-I:
Height UK Concrete ceiling - UK precast part - FT-Height
Cantilever determination WK-I:
Height UK Concrete ceiling - UK brick

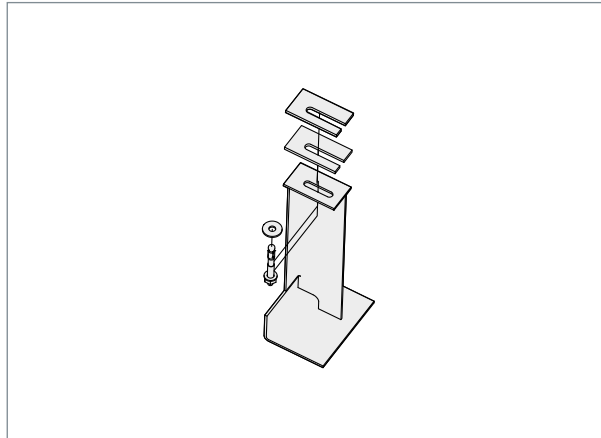

▲ Exploded view WK-I

To allow height adjustment with this anchor system, the accessories include two slotted hole plates (SL):

Washer 110/50/3, SL 13x50, A4/D4 4464103
Washer 110/50/5, SL 13x50, A4/D4 4464105

These can be mounted in four combinations to the initial base for height levelling:
Example FB-I-360-1,0 with a cantilever of 360 mm, the 5 mm SL is included.

Cantilever size [m]	Action
355	No SL plate
358	only the SL plate 3 mm
360	Standard SL plate 5 mm
363	Standard SL plate 5 mm + 3 mm

For repeat orders, the clamping dimension (SL panels incl. anchor plate) must not exceed 30 mm.

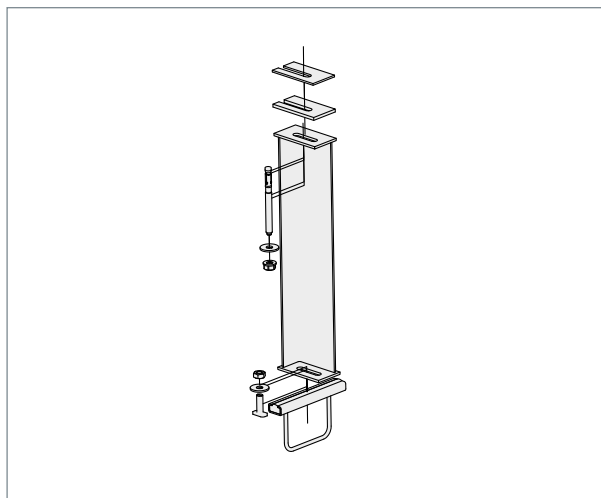

▲ Exploded view FB-I

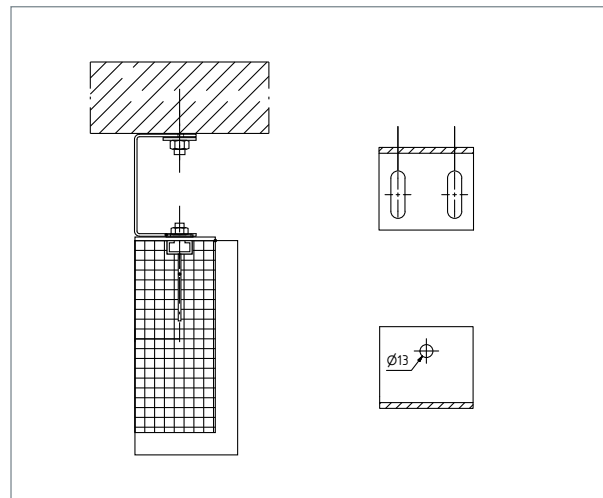

▲ FB-IS special design for narrow clearances

Example order: WK-I - 240 - 1,0-2520-2R

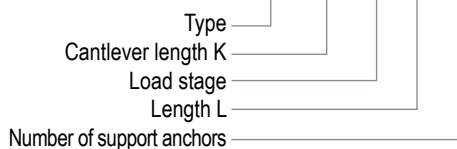

Example order: FB-I - 360 - 1,0

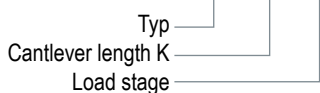

Tender text

Delivery and professional installation of ... m wall bracing with MOSO® angle support bracket type WK-I-240-1,0-2520-2R for a brickwork height of ... m, wall clearance (insulation and air layer) of ... cm, facing brick thickness of ... cm, incl. dowels for cracked concrete⁵⁾.

Tender text

Delivery and professional installation of ... pieces of MOSO® precast part fixing FB-I-360-1,0 incl. dowels for cracked concrete³⁾ and type approved fixing for anchor channel concreted into the precast part.



Special solutions

The MOSO® special solutions are calculated individually by our engineering office to ensure optimal solutions even in difficult conditions.

Product info

- Load stages: as required
- Wall clearances: as required
- Material: stainless steel
corrosion resistance class (CRC) I-V
- Validation: structural calculation

Subsequent increase of the shell distance

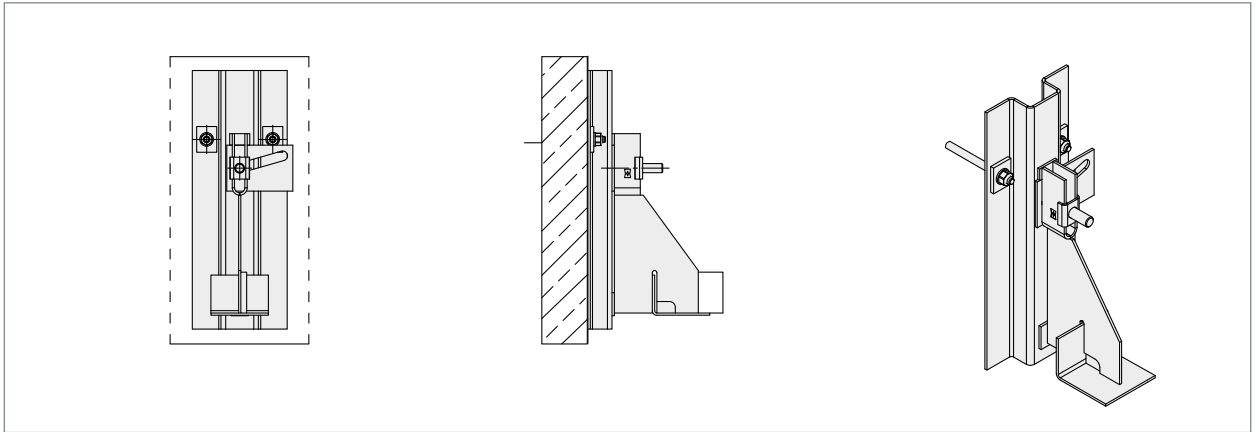

▲ At profile for increasing the shell distance from 20 mm

Foundation too small, which solution should it be?

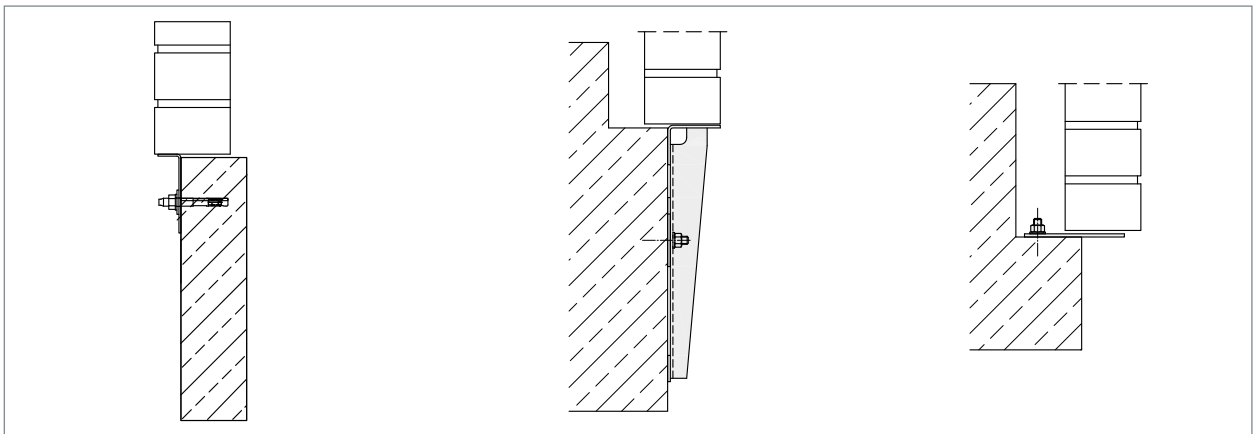

▲ Three options for non-plan foundation widening

Special solutions round off our product range

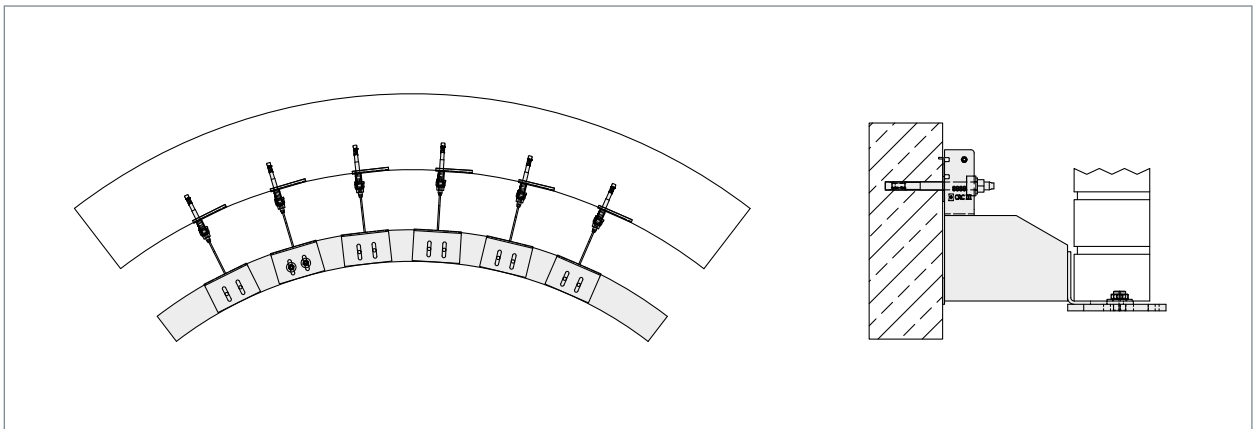

▲ Round interception areas, concave or convex shape possible



Compression strut = pressure stable

Large shell distances result in increased buckling behaviour of the compression strut. This is taken up by the U-profile planned here, in order to be able to plan, calculate and produce cantilevered brackets.

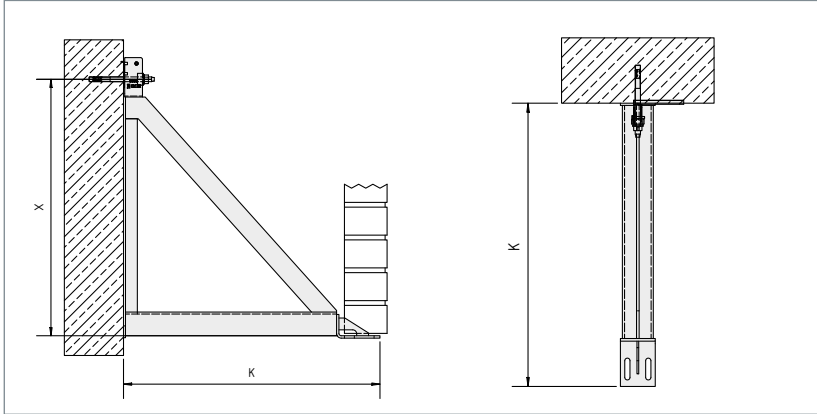

▲ Konsolen mit großem K-Maß, Druckabstützung mittels U-Profil

Tie rod alternative

For situations, e.g. at an outside corner, but where no reinforced concrete support or wall is available, the corner solution comes into play. With an additional pressure support angle, the load on the anchor is completely reduced.

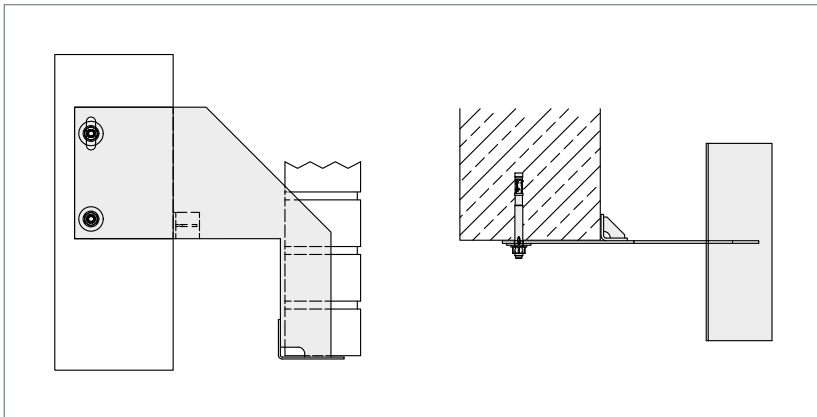

▲ Corner anchor as an alternative to the tie rod

Underhang precast ceilings

Prefabricated ceilings with apron cladding can be installed using the FB-PA system. For larger distances between the concrete substructure and the upper edge of the FT, we recommend the new FB-PAJ, which can be adjusted in all directions, to ensure that the fitter can make the necessary adjustments during installation.

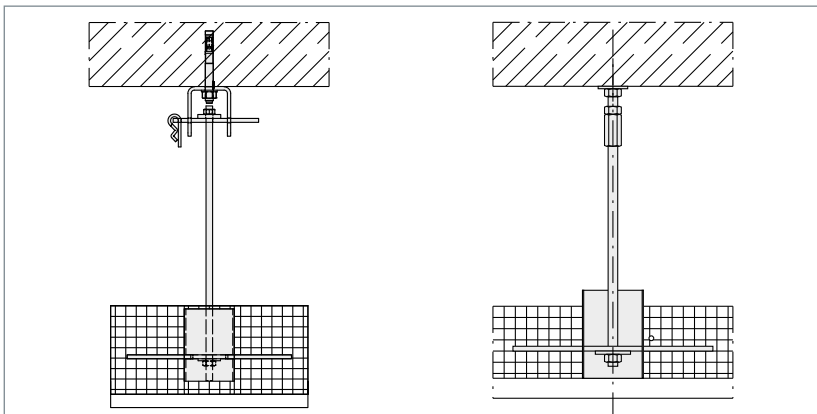

▲ Adjustable ceiling anchor FB-PAJ

▲ Standard ceiling anchor FB-PA

Maximum adjustable

Sloping shells with horizontally stepped facing bricks are an architectural highlight that is uncomplicated to plan and install with this special variant.

A circular toothed double slotted hole variant enables adjustment in the shell spacing, but also in the inclination.

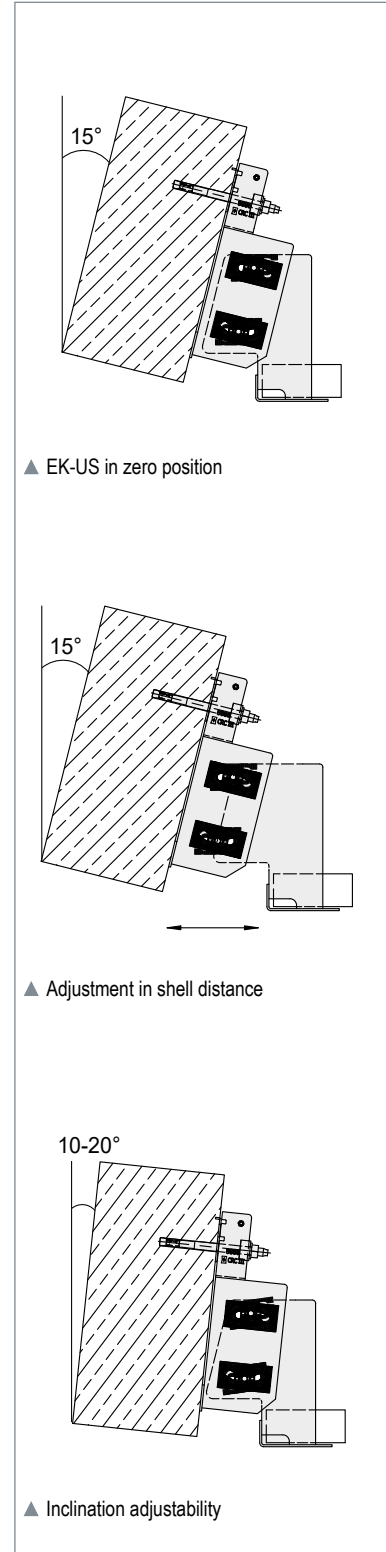

▲ EK-US in zero position

▲ Adjustment in shell distance

▲ Inclination adjustability



Corners and edging left and right

In order to meet the different requirements of building corners, we have developed various corner designs that can be used with every angle bracket anchor.

The respective version is added to the designation, e.g. WK-NAL or WK-NAR....

Due to the wide projection of the angles and the increased requirements on the bracket anchors and fastening, we recommend having the dimensioning carried out by our engineering office.

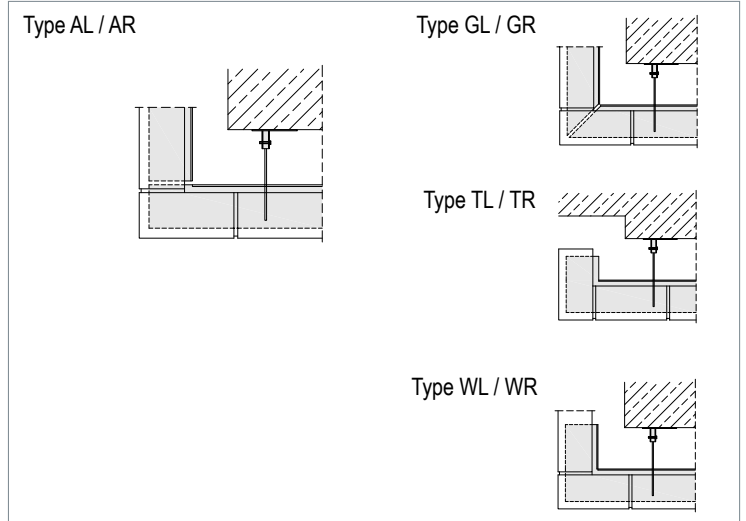

▲ Various corner and edge formations

Abutment in corner areas or near expansion joints

To prevent the corner stones from coming off in the corner area of a suspended facing, abutments are used.

These are firmly welded to the supporting structure and secure the brickwork by means of the spikes that grip into the stones.

Of course, corners of different mitres can also be secured in this way.

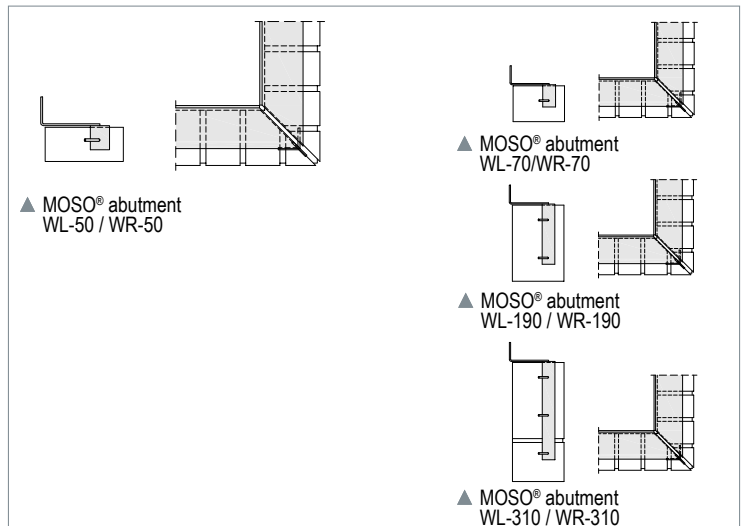

▲ Diverse abutments in corner area, type WL

Like the abutments in corner areas, these abutments prevent facing bricks tilting into the expansion joint.

We recommend abutment dimensioning by our engineering office.

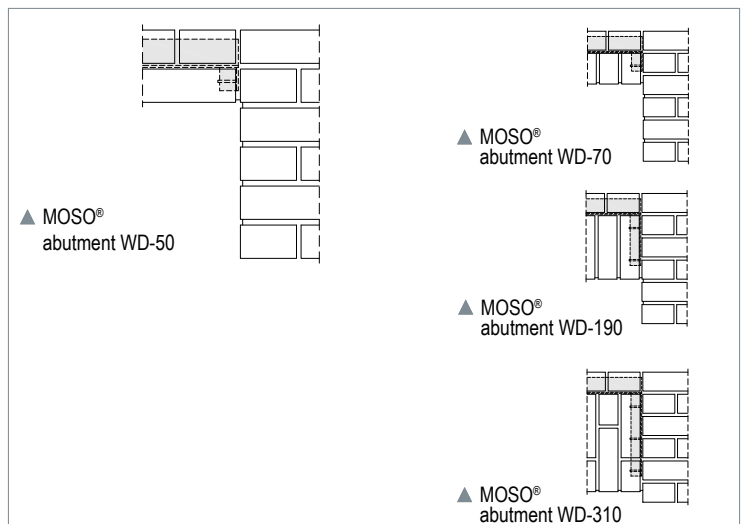

▲ Diverse abutments near expansion joints, type WD

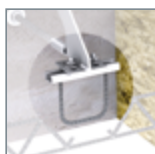

MBA-ES



Accessories

MOSO® Accessories



The Modersohn concrete anchor channels are connecting elements between the precast concrete element and the stainless steel bracket. The anchor channels are available from stock in three load levels in accordance with the building authority approval. The new flat anchor variants are slimmer in design and represent a low-cost alternative to the conventional round anchor variant. The unique selling point of these channels is the 10% load increase with a concrete quality of C35/45.

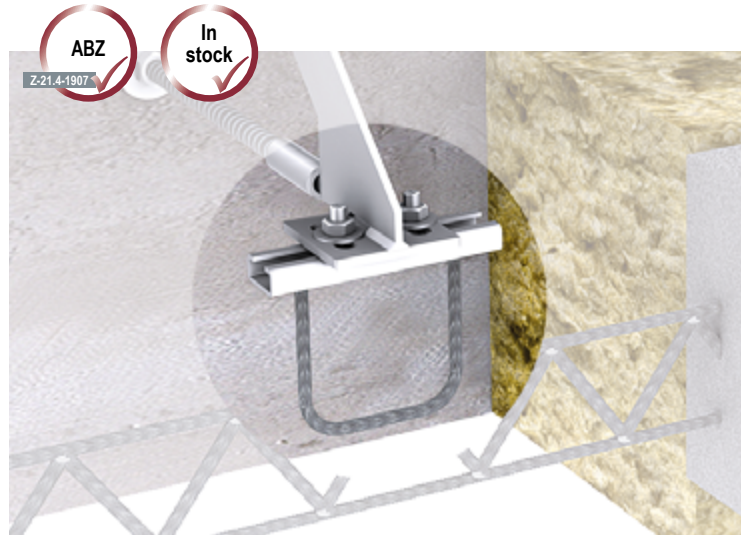

▲ Precast lintel with MOSO® anchor channel MBA-ES set in concrete

Product info

- Construction: Precast lintel with reinforced concrete core
- Type of lintel: Any shape and Brick surface cladding possible
- Material: stainless steel
corrosion resistance class (CRC) I-V
- Validation: Installation part in precast element acc. to DIBt approval Z-21.4-1907

Minimum concrete core dimension

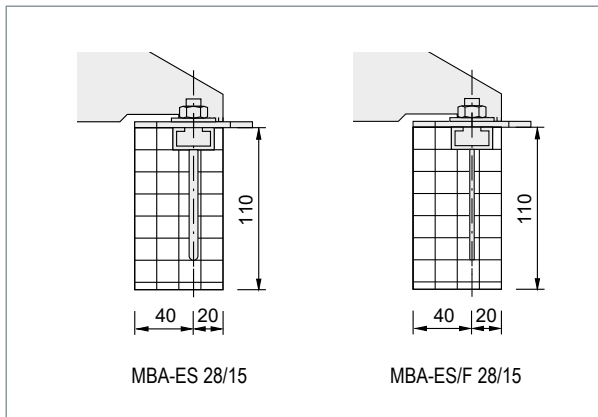

▲ MOSO® MBA-ES and MBA-ESF 28/15

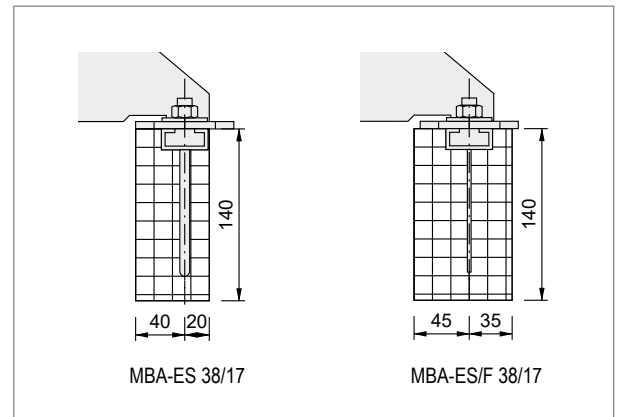

▲ MOSO® MBA-ES and MBA-ESF 38/17

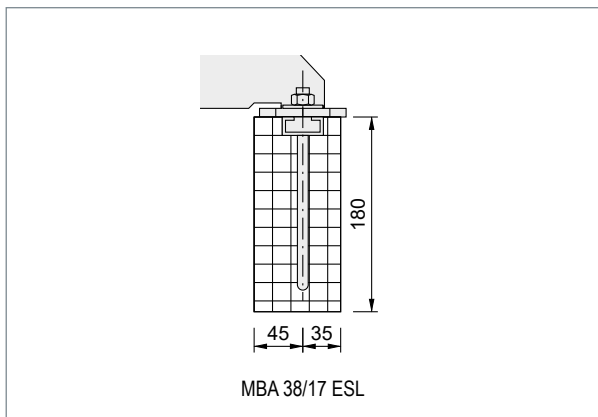

▲ MOSO® MBA-ESL 38/17

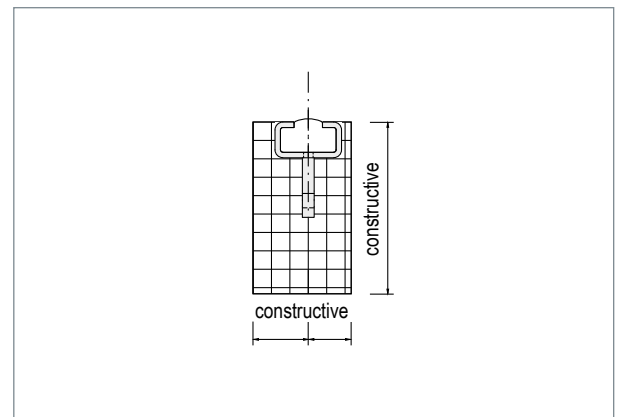

▲ MOSO® TA 28/15 K

Cross-reference for additional information

Page	Topic
83	MBA-CE anchor channel

Example order: MBA - 28/15 - ES

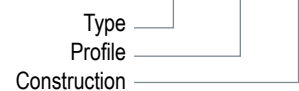



MBA-ES / MBA-ESF

Anchor channel	Load stage [kN] Concrete quality C30 / 37	Construction	Edge distances [cm]					
			d_b	h_b	a_{r1}	a_{r2}	a_e	a_f
MBA 28/15 ES	4,0	Round anchor	6	11	4	2	12.5	25
MBA 28/15 ES/F	4,0	Flat anchor						
MBA 38/17 ES	8,0	Flat anchor	6	14	4	2	15	30
MBA 38/17 ES/F	8,0	Flat anchor						
MBA 38/17 ESL	12,0	Round anchor	8	18	4.5	3.5	17.5	35
TA 28/15 K	constructive	Flat anchor	Constructive without approval for e.g. anti-tilt devices					

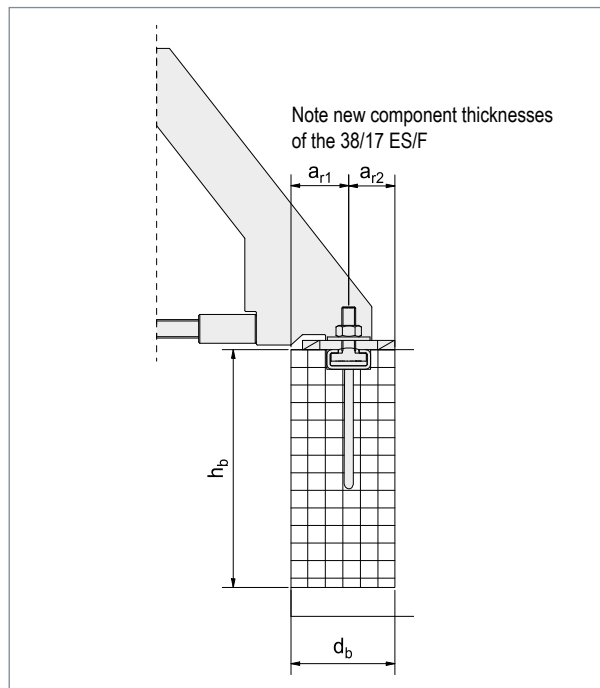

▲ Minimum concrete core dimensions, according to approval

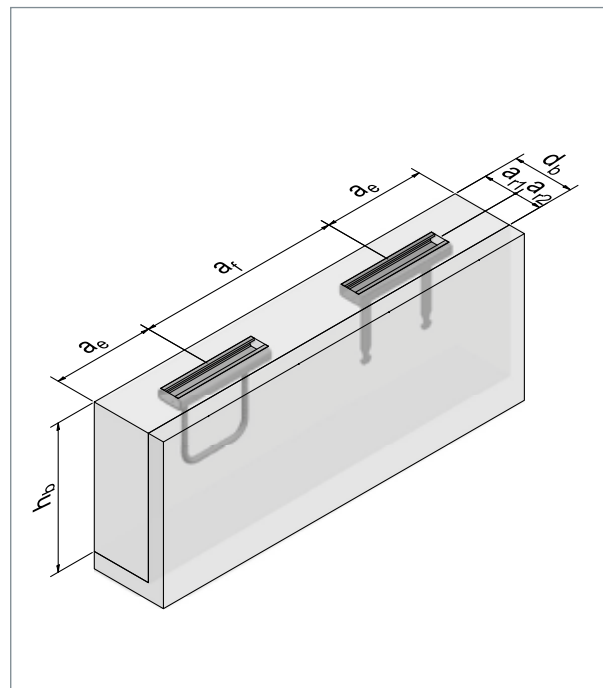

▲ Left MBA 38/18 ES, right MBA 38/17 ESF

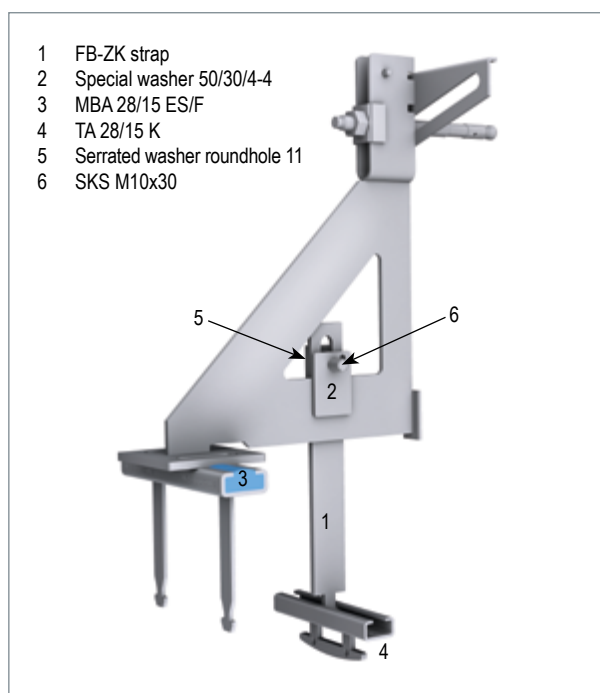

▲ Overview of accessories for anti-tilt device on FB-U console

Anti-tilt device for precast soffits

- For precast soffits \geq the brick length, we recommend the ZK-tab as a bricklaying aid to prevent the lintel from twisting.
- The entire system can be delivered from the warehouse and mounted on storage brackets.
- No additional anchoring to the shell is necessary.
- As installation part in the prefabricated leg we recommend the constructive TA 28/15 K channel.

Wire bracket alternative to precast lintel

Use and application

- Distance between wire brackets for brick lintels \leq 25 cm
- In the case of masonry lintels and poor mortar adhesion of the facing stone, suitable securing measures such as longitudinal reinforcement or the formation of mortar pockets have to be considered.
- Full-surface support of the interception structure until the masonry mortar has hardened is absolutely necessary for masonry lintels.

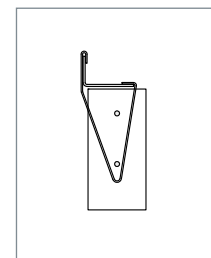

▲ Locally bricked up grenadier layer by means of wire bracket DB-1 below WA-Ü mountable



Accessories

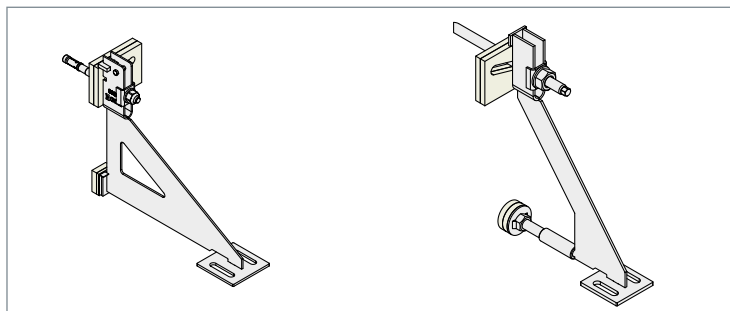

▲ FB-U console with KS TAK1 MOSOTherm t = 20 mm and DVE 15 MOSOTherm
▲ FB-D console with KS TAK2 MOSOTherm t = 20 mm and pressure screw DVR20 (pre-assembled)

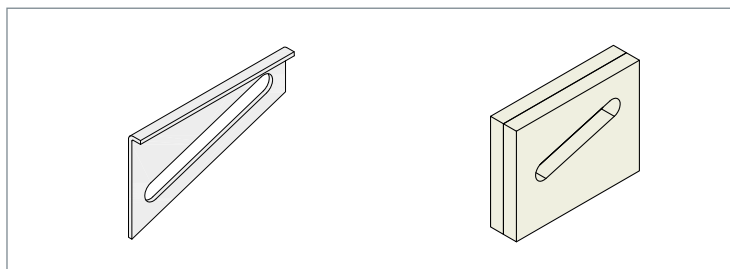

▲ KS 13 trapezoidal D4 and KS TAK1 MOSOTherm t = 20mm

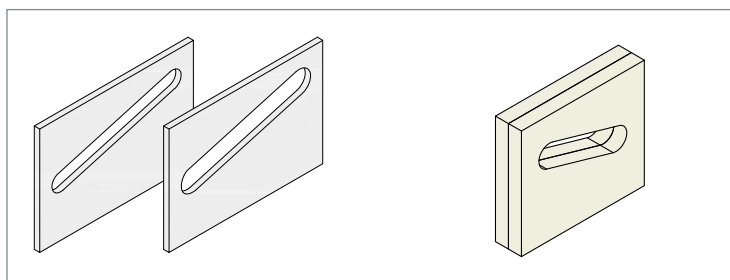

▲ TAK2 KS in D4 for M12 and M16
▲ TAK2 KS MOSOTherm in 20 mm

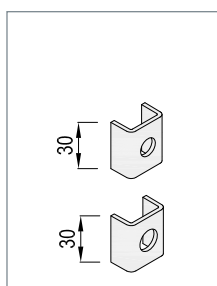

▲ USG11 (TAK1) and USG13 (TAK1)

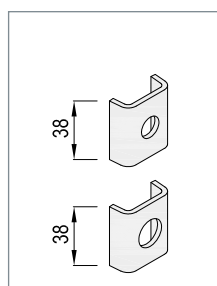

▲ USG13 (TAK2) and USG17 (TAK2)

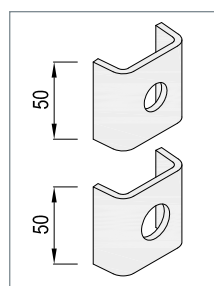

▲ USG17 (TAK3) and USG21 (TAK3)

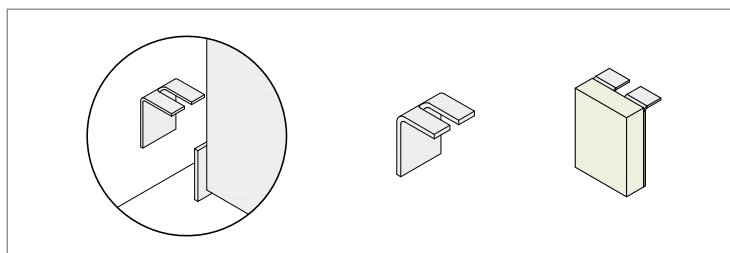

▲ DVW2 (stainless steel) and DVE10 (with 10 mm MOSOTherm)

Accessories for support anchor heads TAK

- Stainless steel
- Corrosion resistance class (CRC) I-V
- MOSOTherm (Glass fibre reinforced plastic GRP)
- For easy reordering
- Goods in stock quickly deliverable
- Product according to approval Z-21.8.-1892

Slotted hole plate TAK1

Art.-No.	Designation
4461181	Slotted hole plate 115/67/13 TAK1, t = 12,5 mm D4
4461130	Slotted hole plate 155/60/13 MO-DA-8,0, D4
4461512	Slotted hole plate 95/74/12,5 TAK1 MOSOTherm t = 5 mm
4461012	Slotted hole plate 95/74/12,5 TAK1 MOSOTherm t = 10 mm
4461812	Slotted hole plate 95/74/12,5 TAK1 MOSOTherm t = 15 mm
4461912	Slotted hole plate 95/74/12,5 TAK1 MOSOTherm t = 20 mm

Slotted hole plate TAK2 and 3

Art.-No.	Designation
4461212	Slotted hole plate 110/84/12,5 TAK2, D4
4461216	Slotted hole plate 110/84/16,5 TAK2, D4
4461316	Slotted hole plate 110/84/16,5 TAK3, D4
4461320	Slotted hole plate 110/84/20,5 TAK3, D4
4461526	Slotted hole plate 95/84/16,5 TAK2 MOSOTherm t = 5 mm
4461026	Slotted hole plate 95/84/16,5 TAK2 MOSOTherm t = 10 mm
4461826	Slotted hole plate 95/84/16,5 TAK2 MOSOTherm t = 15 mm
4461826	Slotted hole plate 95/84/16,5 TAK2 MOSOTherm t = 15 mm
4461926	Slotted hole plate 95/84/16,5 TAK2 MOSOTherm t = 20mm

Cranked washer for TAK1-3

Art.-No.	Designation
446011	Cranked washer roundhole 11 mm TAK1, D4
446013	Cranked washer roundhole 13 mm TAK1, D4
4446012	Cranked washer roundhole 12 mm TAK2, D4
446017	Cranked washer roundhole 17 mm TAK2, D4
446018	Cranked washer roundhole 17 mm TAK3, D4
446021	Cranked washer roundhole 21 mm TAK3, D4

Pressure distribution angle from 2 - 15 mm

Art.-No.	Designation
446302	Pressure distribution angle L 40/28/2...30, A4/D4
446303	Pressure distribution angle L 40/28/3...30, A4/D4
446304	Pressure distribution angle L 40/28/4...30, A4/D4
4463044	Pressure distributor DVE5 L 40/30/5+1 D4 / MOSOTherm
4463045	Pressure distributor DVE10 L 40/30/10+1 D4 / MOSOTherm
4463046	Pressure distributor DVE15 L 40/30/15+1 D4 / MOSOTherm

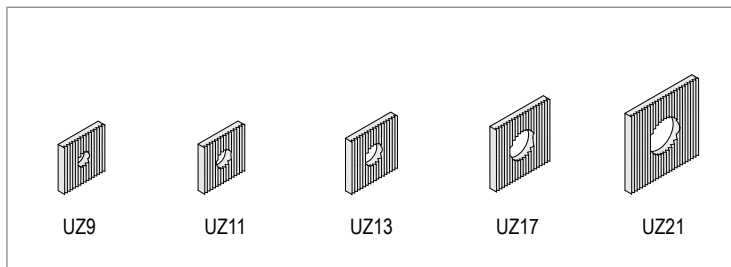

▲ Serrated washers

Product info toothed washer

- Stainless steel
- Corrosion resistance class (CRC) I-V
- Serrated washers
- Very good form lock through milling
- Use for many applications where adjustment with high force transmission is required

Art.-No.	Designation
545009	Serrated washer 30/30/5, roundhole 9 mm A4/D4
545011	Serrated washer 30/30/5, roundhole 11 mm A4/D4
545013	Serrated washer 34/34/5, roundhole 13 mm A4/D4
545017	Serrated washer 40/40/5, roundhole 17 mm A4/D4
545021	Serrated washer 45/45/5, roundhole 21 mm A4/D4

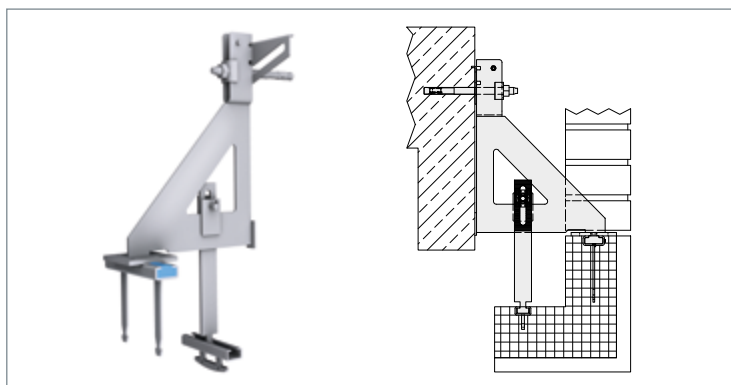

▲ Accessories for precast tilt protection

Product info anti-tilt device for FT soffit

- Stainless steel
- Universal pull tab for MOS 28/15 profiles
- Counterpart to the serrated US, for fine, force-fit height adjustment

Art.-No.	Designation
500103	Type FB-ZK-100-3,5
500153	Type FB-ZK-150-3,5
5001735	Type FB-ZK-175-3,5
500203	Type FB-ZK-200-3,5
500253	Type FB-ZK-250-3,5
500303	Type FB-ZK-300-3,5
5003535	Type FB-ZK-350-3,5

4464244	US 50/30/4-4 mm, roundhole M10, A4/D4
104397	SKS DIN 933 -A4 M 10 x 30 mm

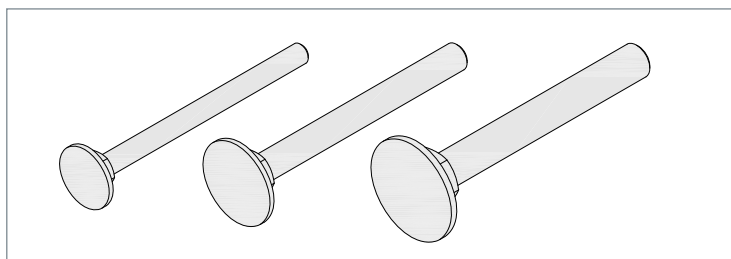

▲ Pressure screws FB-DS1-M12, FB-DS1-M16 and FB-DS1-M20

Product info FB-DS

- Stainless steel
- Corrosion resistance class (CRC) I-V
- Pressure screw
- Use for WK-D bracket
- Continuous adjustment possible
- Available in M12, M16 and M20

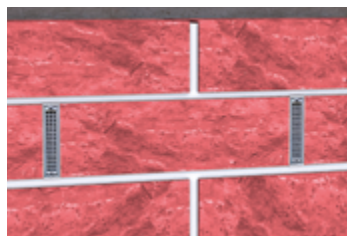

▲ Air joint element LUFU

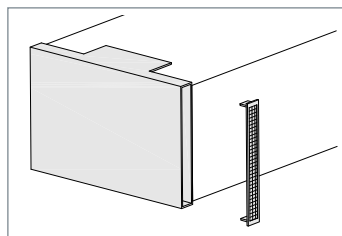

▲ LUFU element with sieve

Product info LUFU

- As vermin protection in the masonry facade
- Brick format: NF (240/115/71)
DF (240/115/52)
- Material: ageing resistant plastic
- Colours: white, concrete grey or anthracite

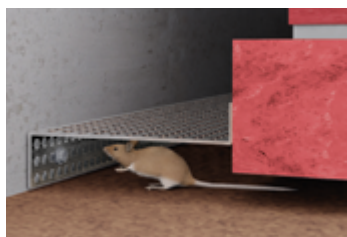

▲ Vermin protection: Perforated plate

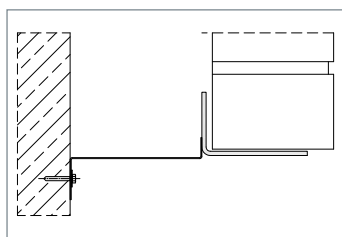

▲ Perforated plate profile

Product info perforated plate

- As vermin protection in the masonry facade
- Materials: stainless steel, aluminium
- Profile lengths: up to 2,000 mm
- Shade: silver (painted on request)
- Installation accessories: depending on application
- self-tapping screws
- plastic dowels



Accessories

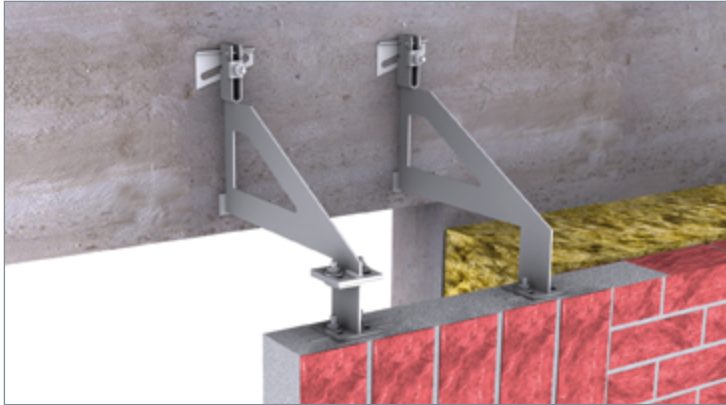

▲ Storage console FB-U with FB-V or production FB-UV console

Product info WK-E / EK-E

- Stainless steel
- Corrosion resistance class (CRC) III
- 450 or 1275 mm rail length
- Anchor arrangement also for outer corners
- For superimposed heights > 9 m (depending on facing brick)
- Adjustable in length on site
- In the "modular system" with FB-U and FB-V consoles
- Available from stock

Art.-No.	Designation
4438001	Angle element WK-E-1275
4438002	Angle element EK-E-450

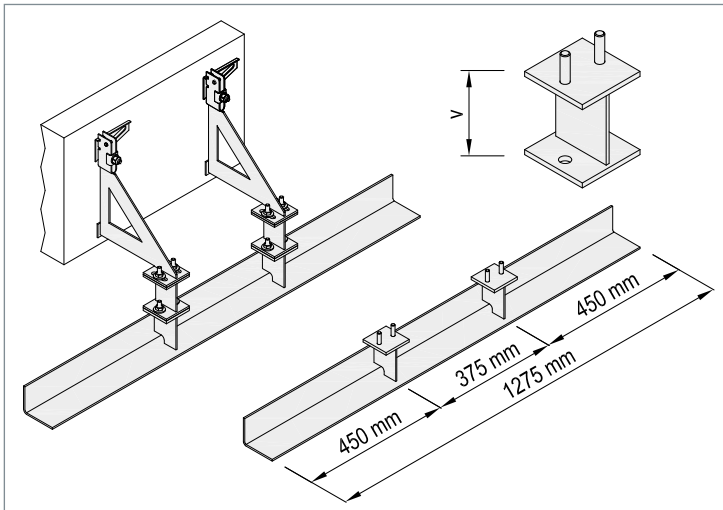

▲ From left: FB-U bracket combined with FB-V and WK-E, spacer FB-V and angle element WK-E

Product info FB-V

- Stainless steel
- Corrosion resistance class (CRC) III
- Spacer FB-V and angle element WK-E
- Only in connection with FB-U console
- Available in sizes 50 to 300 mm
- Can be combined with FB brackets or with angle element EK-E or WK-E

Art.-No.	Designation
4438005	Set piece FB-V-50
4438010	Set piece FB-V-100
4438015	Set piece FB-V-150
4438020	Set piece FB-V-200
4438025	Set piece FB-V-250
4438030	Set piece FB-V-300
4438006	Set piece FB-VZ-50

FB-R - adjustable by the customer

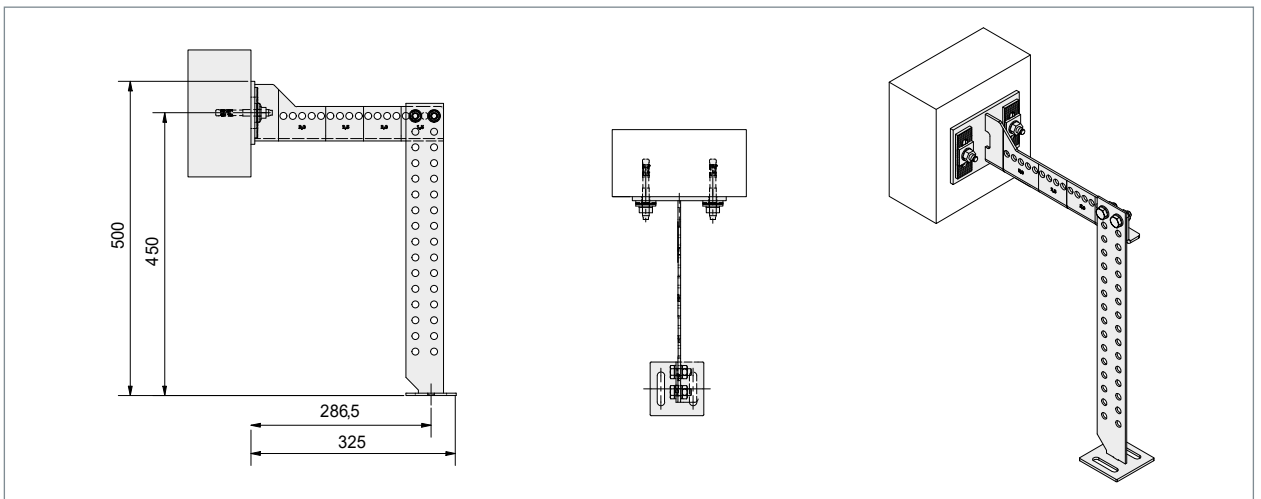

▲ The design of the FB-R allows anchoring, e.g. to reinforced concrete ceilings

The MOSO® precast fastening FB-R is the adjustable anchor for fastening precast lintels to small reinforced concrete components. This anchor allows regulation of the cantilever and offset dimensions and can therefore be used individually in various situations.

Product info

- Cantilever 115 mm - 325 mm
- Load level 1.5 kN to 3.0 kN (depending on cantilever)
- Offset 75 mm to 450 mm
- Validation: structural calculation



MA-A

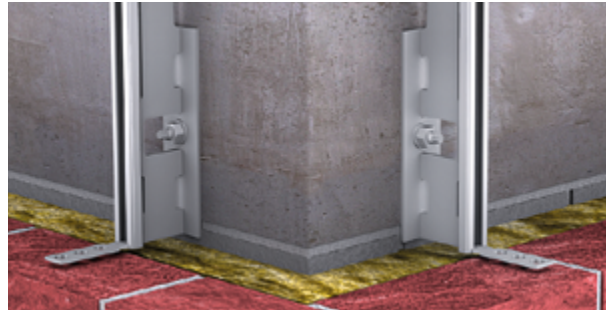
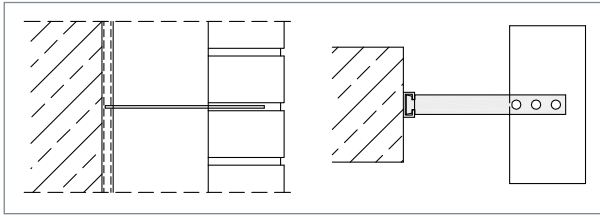

Art.-No.	Designation
150529	MAA-85-A4 wall anchor
150545	MAA-180-A4 wall anchor
150533	MAA-120-A4 wall anchor

▲ 3 MA-A lengths in stock for HV-A or HV-WP anchor systems

MA-A Special form

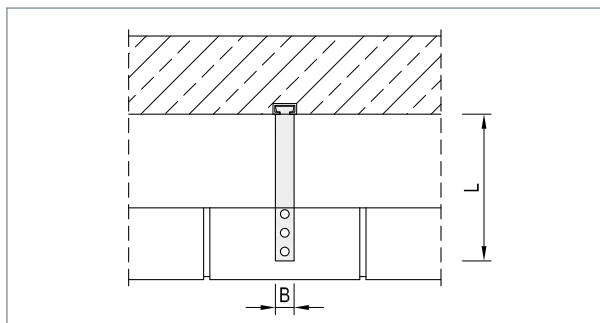

▲ MOSO® wall anchor MA-A

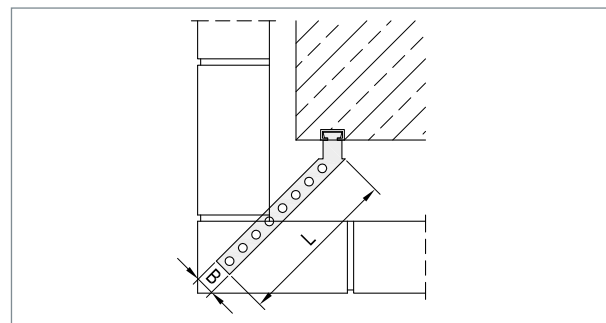

▲ MOSO® wall anchor MA-AW

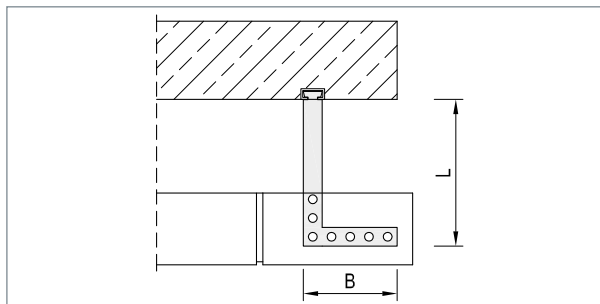

▲ MOSO® wall anchor MA-AL

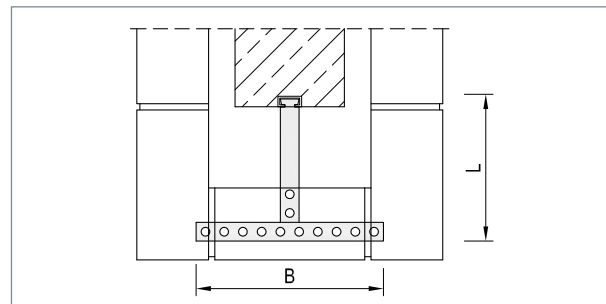

▲ MOSO® wall anchor MA-AT

Soffit sheet

Art.-No.	Designation
4498922	Soffit sheet 210/120/3 A4/D4
4498921	Soffit sheet 210/85/3 D4

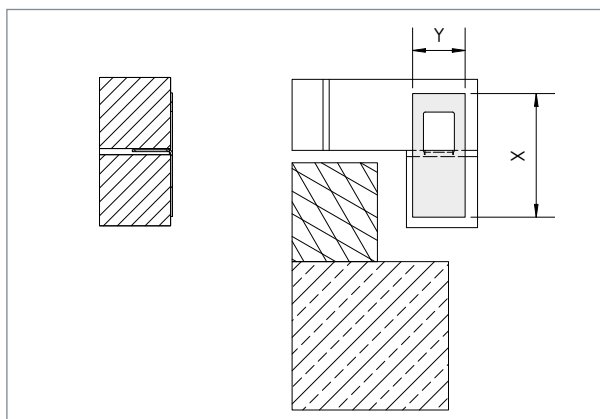

▲ Soffit sheet as brick support for facing soffits in stone length

Push-on angle

Art.-No.	Designation
4498960	Push-on angle up to 60 mm angular back
4498980	Push-on angle up to 80 mm angular back

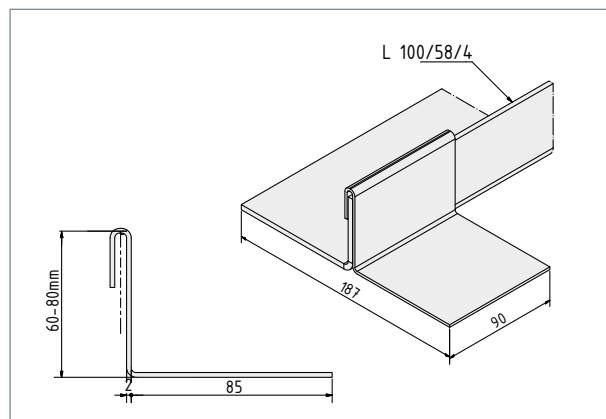

▲ Another option for bricking up soffits



Corrosion resistance classes - CRC IV

Due to loads from salty air, such as near the coast or sulphur dioxide loads, the choice of material for heavy-duty fastening must also be considered with regard to the corrosion resistance classes.

For this purpose, Modersohn keeps a large stock of the material 1.4462 in order to be able to supply projects in the CRC IV class quickly and at stable costs.



▲ Installation of the material samples in the Elbe Tunnel Hamburg, as part of a research project to expand the application range of the material 1.4462.

Determination of the corrosion resistance class (CRC)

Corrosion resistance factor (CRF)	Corrosion resistance class (CRC)
CRF = 1	I
$0 \geq \text{CRF} > -7$	II
$-7 \geq \text{CRF} > -15$	III
$-15 \geq \text{CRF} > -20$	IV
CRF < -20	V

Steel grades in every corrosion resistance class

Corrosion resistance class (CRC)				
I	II	III	IV	V
1.4003	1.4301	1.4401	1.4439	1.4565
1.4016	1.4307	1.4404	1.4462	1.4529
1.4512	1.4311	1.4571	1.4539	1.4547
	1.4541	1.4162		1.4410
	1.4318	1.4362		1.4501
	1.4482	1.4062		1.4507

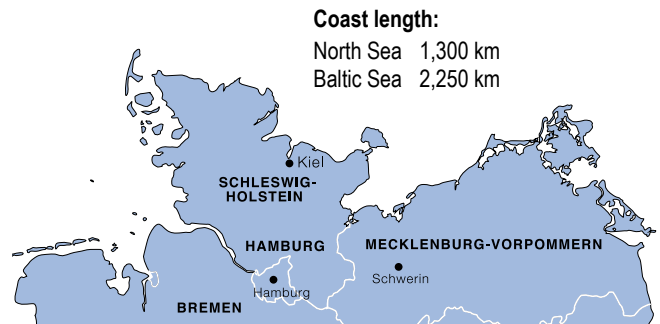

The steel grade of a higher class may be used instead of the one specified by the CRF.

Note: The corrosion resistance classes are only intended for use with this steel grade selection procedure and apply only to structures with a load-bearing function.

Determination of the corrosion resistance factor $\text{CRF} = F_1 + F_2 + F_3$

F_1 Risk of exposure to chlorides from salt water or de-icing salts (road salt).		
NOTE M is the distance from the sea and S is the distance from roads with the use of de-icing salts		
1	indoor areas	
0	Low risk of exposure	$M > 10 \text{ km}$ or $S > 0.1 \text{ km}$
-3	Medium risk of exposure	$1 \text{ km} < M \leq 10 \text{ km}$ or $0.01 \text{ km} < S \leq 0.1 \text{ km}$
-7	High risk of exposure	$0.25 \text{ km} < M \leq 1 \text{ km}$ or $S \leq 0.01 \text{ km}$
-10	Very high risk of exposure	Road tunnels where de-icing salt is applied or where vehicles could introduce de-icing salt into the tunnel.
-10	Very high risk of exposure	$M \leq 0.25 \text{ km}$ (North Sea coast of Germany and all coastal regions of the Baltic Sea)
-15	Very high risk of exposure	$M \leq 0.25 \text{ km}$ (Atlantic coast, coast of the English Channel and North Sea regions, Mediterranean coast)

F_2 Risk of exposure to sulphur dioxide		
0	Low risk of exposure	Average value of the gas concentration $< 10 \mu\text{g}/\text{m}^3$
-3	Medium risk of exposure	Average value of the gas concentration $10 \mu\text{g}/\text{m}^3$ bis $90 \mu\text{g}/\text{m}^3$
-10	High risk of exposure	Average value of the gas concentration $90 \mu\text{g}/\text{m}^3$ bis $250 \mu\text{g}/\text{m}^3$

F_3 Cleaning concept or exposure to wash-off due to rain (if $F_1 + F_2 \geq 0$, then $+ F_3 = 0$)		
0	Full exposure to wash-off due to rain	
-2	Specific cleaning concept	
-7	No washing off due to rain or no specific cleaning	

Extract from DIN EN 1993-1-4: October 2015



Technical details



Hilti HST3-R

Product info

Acc. to **ETA - 98/0001** of Hilti approved for:

- cracked and non-cracked concrete
- concrete grade C20/25 to C50/60
- Seismic category C1 and C2 under certain conditions
- Fire resistance class A1
- Pre- and push-through installation

Observe edge conditions acc. to ETA!



▲ Hilti bolt anchor HST3-R

Technical data

HST3-R M10	HST3-R M12	HST3-R M16	HST3-R M20
Nominal drill diameter d_0 [mm]			
10	12	16	20
Drill hole depth h_0 [mm]			
73	88	106	124
Minimum component thickness h_{min} [mm]			
120	140	160	200
Torque T_{inst} [Nm]			
45	60	110	180

Use and application

- Produce drill hole with hammer drill, clean drill hole, set anchor
- Produce drill hole with diamond drill, clean / rinse out drill hole, set anchor
- Splay anchor with installation torque
- Dowels should be placed by trained specialist staff

fischer FSB

Product info

Acc. to **ETA - 12/0258** of fischer approved for:

- cracked and non-cracked concrete
- concrete grade C20/25 to C50/60
- Seismic category C1 and C2 under certain conditions
- Fire resistance class A1

The super-bond system comprises:

Anchor rod RG M with inclined ceiling

Reaction cartridge RSB or

Super-bond mortar FIS SB:

- up to 3 installation heights possible with RSB (e.g. RSB 10mini, RSB 10, 2xRSB 10mini)

Observe edge conditions acc. to ETA!



▲ fischer Super-bond-system

Technical data

RG M10	RG M12	RG M16	RG M20
Nominal drill diameter d_0 [mm]			
12	14	18	25
Reaction cartridge RSB			
10mini / 10	12mini / 12	16mini / 16	20 / 20E
Drill hole depth h_0 [mm]			
75 / 90	75 / 110	95 / 125	170 / 210
Minimum component thickness h_{min} [mm]			
105 / 120	105 / 140	131 / 161	220 / 260
Torque T_{inst} [Nm]			
20	40	60	120

Use and application

- Installation temperatures: min. cartridge temperature - 15 °C
min. cassette temperature + 5 °C
- Anchoring base: from - 15 °C for FIS SB and RSB
- Please observe processing and waiting times before attaching load!
- Drill hole production only with a hammer drill
- FIS SB: 2x blowing, 2x brushing, 2x blowing
- RSB: 4x blowing (diamond drill, see ETA)
- When using a mortar cartridge, the anchor rod is placed with a hammer drill with rotary and hammering action
- If the dowel is installed correctly, mortar should come out of the drill hole mouth
- Dowels should be placed by trained specialist staff

fischer FAZ II



Product info

Acc. to **ETA - 05/0069** of fischer approved for:

- cracked and non-cracked concrete
- concrete grade C20/25 to C50/60
- Seismic category C1
- under certain conditions
- Fire resistance class A1
- Pre- and push-through installation

Observe edge conditions acc. to ETA!



▲ fischer bolt anchor FAZ II

Technical data

FAZ II M10	FAZ II M12	FAZ II M16	FAZ II M20
Nominal drill diameter d_0 [mm]			
10	12	16	20
Drill hole depth h_1 [mm]			
75	90	110	125
Minimum component thickness h_{min} [mm]			
120	140	170	200
Torque T_{inst} [Nm]			
45	60	110	200

Use and application

- Produce drill hole with hammer drill, clean drill hole, set anchor
- Splay anchor with installation torque
- Dowels should be placed by trained specialist staff

Hilti HVU2

Product Info

Mortar capsule to heavy duty anchoring in concrete

Acc. to **ETA - 16/0515** of Hilti approved for:

- cracked and non-cracked concrete
- concrete grade C20/25 to C50/60
- Seismic category C1 and C2
- under certain conditions
- Fire resistance class A1
- Dowelling elements: anchor rod HAS

Observe edge conditions acc. to ETA!



▲ Hilti adhesive capsule HVU2

Technical data

HVU2 M10	HVU2 M12	HVU2 M16	HVU2 M20
Nominal drill diameter d_0 [mm]			
12	14	18	22
Drill hole depth h_1 [mm]			
90	110	125	170
Minimum component thickness h_{min} [mm]			
120	140	160	220
Max. Torque T_{max} [Nm]			
20	40	80	150

Use and application

- Anchoring of steel structures (e.g. shelves, crash barriers, fences and gates)
- Anchoring of construction elements on roads and in tunnels (e.g. guard rails and noise protection, overhead lines)
- Anchorages in industry (e.g. machines, lifts, cranes and industrial plants)
- Anchoring at the edge of concrete slabs or on surfaces with small dimensions (e.g. beams, balconies).
- Anchoring of curtain facades



Hilti-HRD HR

Product info

- Plastic frame dowel / long-shaft fixing
Acc. to **Z-21.2-2034** of Hilti
- Concrete grade C20/25 to C50/60b cracked / non-cracked
 - Acc. to **ETA-07/0219** of Hilti
 - Concrete grade C12/15 to C50/60b cracked / non-cracked
 - Masonry full / perforated / hollow bricks
 - Aerated concrete (non-cracked)
 - Approved as single or group dowels

Observe edge conditions acc. to approval/ETA!

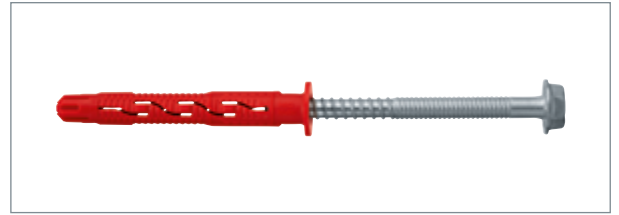

▲ Hilti frame anchors HRD

fischer SXR-FUS

Product info

- Plastic long-shaft fixing
Acc. to **ETA - 07/0121** of fischer approved for:
- Concrete grade \geq C12/15
 - Masonry full / hollow / perforated bricks
 - Aerated concrete (non-cracked)
 - Approved as single or group dowels

Observe edge conditions acc. to ETA!

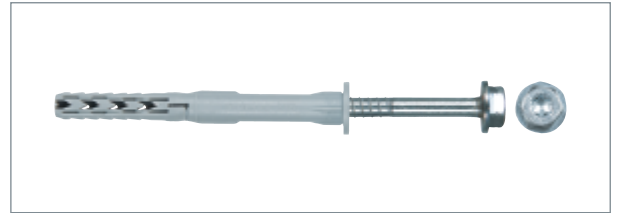

▲ fischer long-shaft fixing SXR

fischer SXS-FUS

Product info

- Plastic long-shaft fixing
Acc. to **Z-21.2-1734** of fischer approved for:
- Concrete grade C20/25 to C50/60b cracked / non-cracked
 - Acc. to **ETA-09/0352** of fischer approved for:
 - Concrete grade \geq C12/15
 - Masonry full bricks
 - Aerated concrete (non-cracked)
 - Approved as single or group dowels

Observe edge conditions acc. to approval/ETA!

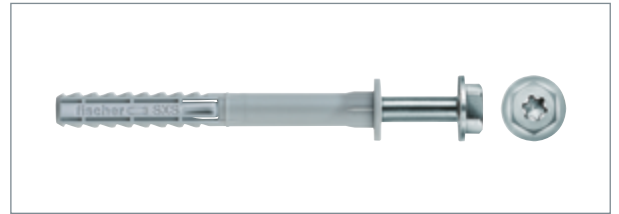

▲ fischer long-shaft fixing SXS

fischer FIS V

Product info

- High-performance mortar
Acc. to **ETA-02/0024** of fischer approved for:
- Injection system - Connecting dowel for anchoring in concrete
 - Acc. to **ETA-08/0266** of fischer approved for:
 - Reinforcement connection with injection mortar
 - Acc. to **ETA-10/0383** of fischer approved for:
 - Injection system - For anchoring in masonry
 - Concrete grade C20/25 to C50/60b cracked / non-cracked • Hollow bricks made of concrete or aerated concrete • Full and vertically perforated brick • sand-lime full bricks and sand-lime perforated bricks • aerated concrete

Observe edge conditions acc. to ETA!



▲ fischer high-performance mortar FIS V

Upat UPM 44

Product info

- Injection mortar
Universal injection mortar for a wide range of applications.
Suitable for concrete, solid and perforated building materials; for carrying medium to heavy loads.

Observe the approvals / ETA of the respective mortars!



▲ Upat injection mortar UPM 44



The anchor channel MBA-CE is technically approved in Europe, and is used as a fixing for installation parts in in-situ concrete, or as an installation part in a precast part. Depending on the installation situation, the MBA-CE anchor channel offers horizontal or vertical adjustment options. The MOSO® hammerhead / hookhead bolts MHK are used as a connection.

The dimensions are shown in the table.

Product info

- Profile sizes: 28/15, 38/17, 40/25, 50/31 and 52/34
further profile sizes on request
- Material: approved stainless steel
- Validation: European approval acc. to ETA-13/0224

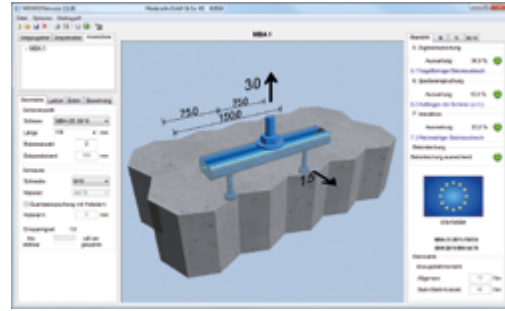

▲ Surface MBA-CE in our free dimensioning software MOSOCONstructor

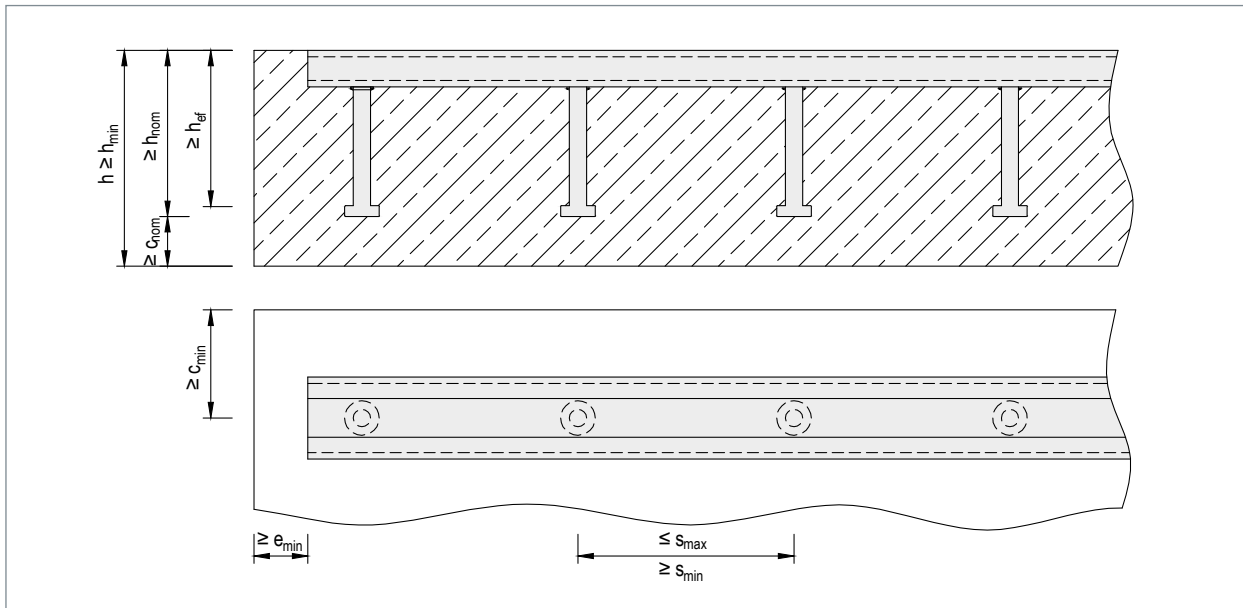

▲ MBA-CE: Installation condition

Example order: MBA - CE - 50/31 - 150

Profile type
Profile size
Profile length

Technical data / measurement chart

MBA-CE

Anchor channels		28/15	38/17	40/25	50/31	52/34
min. h_{ef}	[mm]	45	72	80	99	151
min. h_{nom}	[mm]	50	77	85	106	159
c_{min}	[mm]	40	50	50	75	100
e_{min}	[mm]	15	25	25	50	65
s_{min}/s_{max}	[mm]	50 / 200	50 / 200	50 / 250	50 / 250	80 / 250
h_{min}	[mm]	75	100	110	130	185

Note

The hammerhead/hookhead bolt should be put out for tender separately.

Tender text

Delivery and professional installation of ... pieces of of MOSO® precast part attachment MBA-CE-50/31¹⁾-150²⁾.

¹⁾ Profile size acc. to table

²⁾ Profile length acc. to table

Profile size	Length [mm] ①											MHK	Screw size ①			
	100	150	200	250	300	350	400	550	1050	3025	6050		M10	M12	M16	M20
28/15	x	x	x	x	x	x	x	x	x	x	x	28/15	x			
38/17	x	x	x	x	x	x	x	x	x	x	x	38/17	x	x	x	
40/25		x	x	x	x	x	x	x		x	x	40/25		x	x	
50/31		x	x	x	x	x	x	x	x	x	x	50/30		x	x	
52/34		x	x	x	x	x		x	x	x	x					

① Further dimensions on request.



Technical specifications for masonry support

(Extracts from DIN EN 1996-2/NA:2012-01)

Technical details

NA.D.1 General provisions for execution

- b) The minimum thickness of the outer shell is 90 mm. Thinner outer shells are claddings whose design is regulated in DIN 18515. The length of masonry piers in the outer shell, which only have to bear loads from the outer shell, is at least 240 mm. As a rule, the outer shell must be fully supported over its entire length. In the case of interrupted support (e.g. brackets), all bricks must be supported on both sides in the interception plane.
- d) Outer shells of 115 mm thickness shall be supported at height intervals of about 12 m. They may protrude up to 25 mm above their support. If the 115 mm thick outer shell is not higher than two storeys or is supported every two storeys, it may project up to 38 mm above its support. These projections must be taken into account when verifying the bearing pressure. In the case of subsequent jointing, the joints of the visible surfaces must be scraped out flank clean to a depth of at least 15 mm and then grouted in a manner appropriate to the trade.
- e) Outer shells with thicknesses of $t \geq 105$ mm and $t < 115$ mm must not be higher than 25 m above ground and must be intercepted at height intervals of about 6 m. For buildings with up to two full storeys, a gable triangle up to 4 m high may be executed without additional interception. These outer shells may protrude no more than 15 mm above their support. In the case of subsequent jointing, the joints of the visible surfaces must be scraped out flank-clean to a depth of at least 15 mm and then grouted in a manner appropriate to the trade.
- f) Outer shells with thicknesses of $t \geq 90$ mm and $t < 105$ mm must not be higher than 20 m above ground and must be intercepted at height intervals of approx. 6 m. For buildings with up to two full storeys, a gable triangle up to 4 m high may be executed without additional interception. The joints of the visible surfaces of these facing shells must be executed in joint smoothing. These outer shells may protrude no more than 15 mm above their support.

- g) The masonry shells are to be connected by anchors according to the general building authority approval made of stainless steel or by anchors according to DIN EN 845-1 made of stainless steel, the use of which is regulated in a general building authority approval. For wire anchors corresponding in shape and dimensions to Figure NA.D.1 applies:

- vertical spacing: max. 500 mm
- horizontal spacing: max. 750 mm
- clear span of masonry shells: max. 150 mm
- Diameter: 4 mm
- Regular brick mortar: min. group IIa
- Minimum quantity: see table NA.D.1

unless otherwise specified in the approval for the wire anchors. At all free edges (of openings, at building corners, along expansion joints and at the top ends of outer shells), three wire anchors per metre of edge length shall be placed in addition to Table NA.D.1.

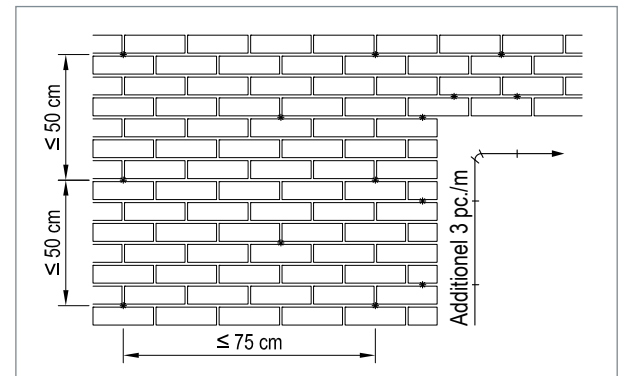

▲ Arrangement of wire anchor acc. to DIN EN 1996-2/NA:2012-01

The wire anchors are to be designed in such a way that they cannot conduct moisture from the outer to the inner shell, taking into account their static effectiveness. (e.g. sliding on a plastic sheet, see Figure NA.D.1).

If the outer shell is anchored in a non-planar manner, e.g. in a line or only at the level of the ceilings, its stability must be verified.

In the case of curved masonry shells, the type, arrangement and number of anchors must be determined taking the deformation into account.

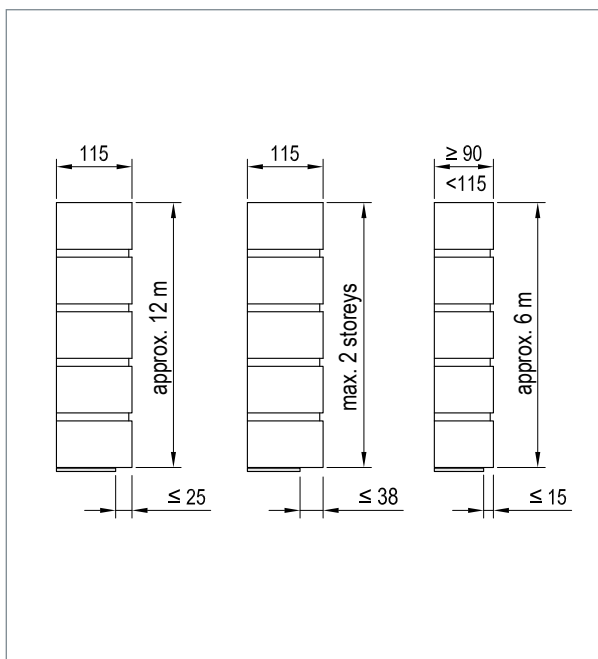

▲ Max. brick overhang acc. to DIN EN 1996-2/NA:2012-01

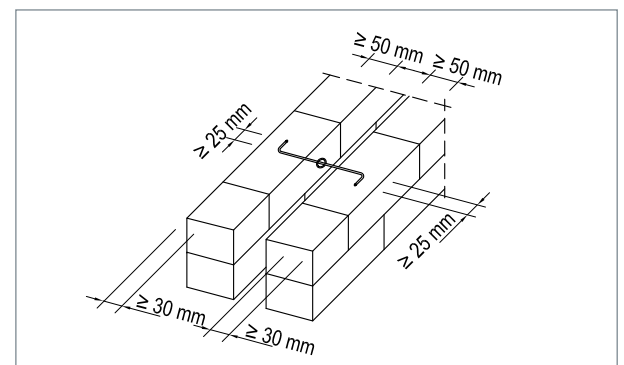

▲ Image NA.D.1

- i) Interception structures that can no longer be inspected after installation must be made of materials that are permanently corrosion-resistant and standardised or approved by the building authorities for the application.

Technical specifications for masonry support



Number of wire anchors acc. to Approval Z.17.1-825 for shell spacings ≤ 200 mm

Building height	Wind zones 1 to 3 Wind zone 4 Inland	Wind zone 4 North and Baltic Sea coast and Baltic Sea islands	Wind zone 4 North Sea islands
$h \leq 10$ m	7 ^a	7	8
$10 \text{ m} < h \leq 18$ m	7 ^b	8	9
$18 \text{ m} < h \leq 25$ m	7	8 ^c	not regulated

^a In wind zone 1 and wind zone 2 inland: 5 wall ties per m²

^b In wind zone 1: 5 wall ties per m²

^c If a building layout length is smaller than h/4: 9 wall ties per m²

▲ 4 mm wall ties

Number of wire anchors acc. to Approval Z.17.1-825 for shell spacings > 200 mm to ≤ 250 mm

Building height	Wind zones 1 to 3 Wind zone 4 Inland	Wind zone 4 North and Baltic Sea coast and Baltic Sea islands	Wind zone 4 North Sea islands
$h \leq 10$ m	7 ^a	8	9
$10 \text{ m} < h \leq 18$ m	7 ^b	9	10
$18 \text{ m} < h \leq 25$ m	8	10	not regulated

^a In wind zone 1 and wind zone 2 inland: 5 wall ties per m²

^b In wind zone 3, Baltic Sea islands and coastal areas: 8 wall ties per m²

▲ 4 mm wall ties

Number of wire anchors acc. to Approval Z.17.1-825 for shell spacings > 200 mm to 400 mm

Building height	Wind zones 1 to 3 Wind zone 4 Inland	Wind zone 4 North and Baltic Sea coast and Baltic Sea islands	Wind zone 4 North Sea islands
$h \leq 10$ m	7 ^a	7	8
$10 \text{ m} < h \leq 18$ m	7 ^b	8	9
$18 \text{ m} < h \leq 25$ m	7	8 ^c	not regulated

^a In wind zone 1 and wind zone 2 inland: 5 wall ties per m²

^b In wind zone 3, Baltic Sea islands and coastal areas: 8 wall ties per m²

▲ 5 mm wall ties



A coastal region is defined as follows:
it comprises a strip running in parallel
with the coast and reaching 5 km inland.

◀ Wind zone map acc. to
DIN EN 1991-1-4/NA:2010-12



Technical specifications for expansion joint arrangement

According to DIN EN 1996-2/NA:2012-01, vertical expansion joints must be placed in facing shells. Expansion joints serve to compensate deformations between the outer shell and common brickwork. Their distances depend on the orientation of the external wall which is subject to the varying climatic stress (temperature fluctuations, humidity, etc.), the type of material, and the colour of the outer shell. Where cavity walls are used, these arise mainly due to temperature

movements of the outer shell and by creep and shrinkage of the supporting common brickwork. It is therefore recommended that expansion joints of $L_R > 10$ m be arranged on longer walls to facilitate absorption of these deformations without causing damage. The following table shows reference values for the spacing of vertical expansion joints. The values have been substantiated through experience, as well as calculations and analyse.

Reference values for expansion joint spacing l_m according to DIN EN 1996-2:2010-12

Wall construction	Expansion joint spacing L_R [m] for	
	Brick masonry ①	Limestone/sandstone masonry ①
Double-skin facing masonry with air layer	10 - 12	6 - 8
Cavity walls with air layer and thermal insulation	10 - 12	6 - 8
Cavity facing walls with core insulation	10 - 12	5 - 6
Cavity facing walls with plaster layer	10 - 12	-

① Smaller intervals should be selected for surfaces exposed to strong sunlight, dark stone surfaces and/or facing shells with low mass.

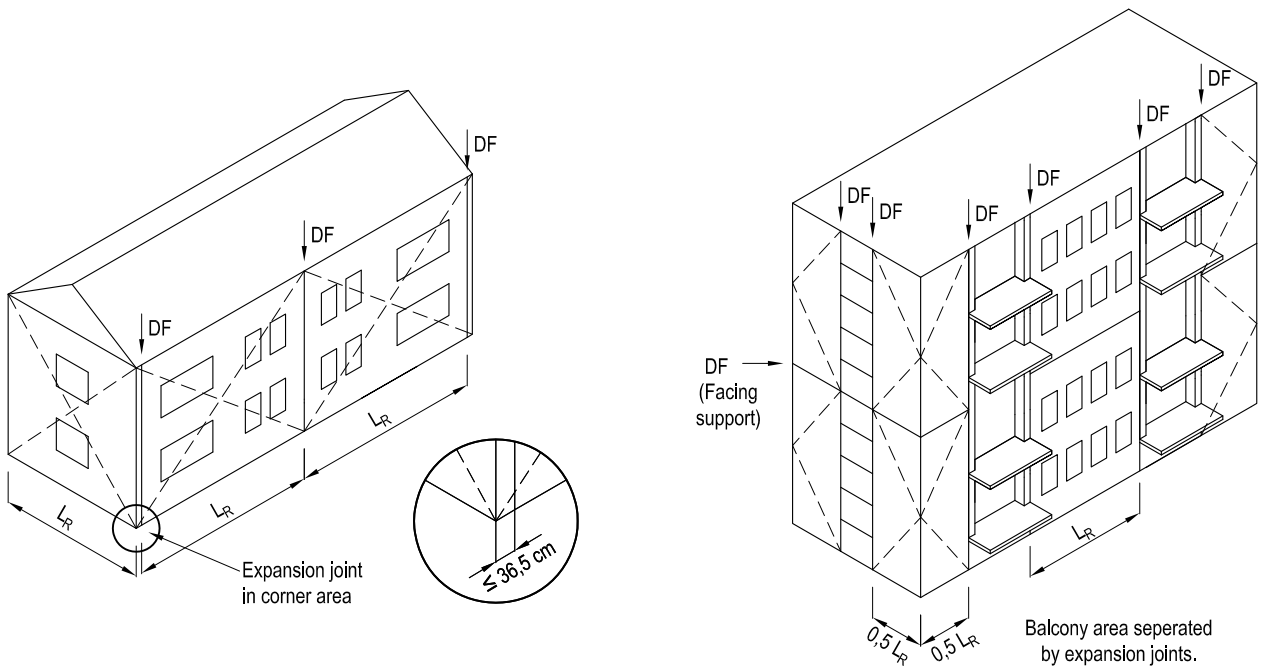

Possible arrangement of vertical expansion joints in corner areas

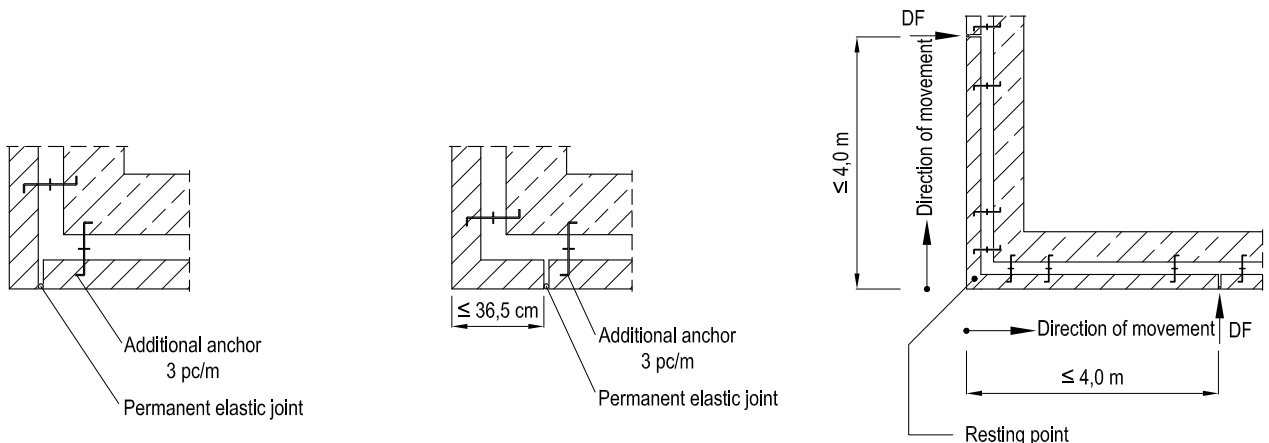

Technical specifications for expansion joint arrangement



Prevent cracks

The risk of crack formation is higher if unhindered expansion of the facing masonry is not possible when affected by temperature. For instance, the installation of support brackets create fixed points in the facade which counteract natural expansion.

Due to the fixed connection with the supporting wall, the brackets are fixed such that tensions will invariably build up in the facade when exposed to high or low temperatures. In our experience, these tensions are not critical if the facade expansion is only possible above a

storey height of 3 m, as the expansion potential is only 1 to 1.5 mm. If expansion is across 2 storeys, it already amounts to 2 to 3 mm. These movements suffice to cause cracks in the facade.

The use of MOSO® perforated strip as joint reinforcement significantly lowers the crack formation risk. From a technical perspective, however, expansion joints arrangements that allow for virtually unhindered facade expansion are more effective than joint reinforcements.

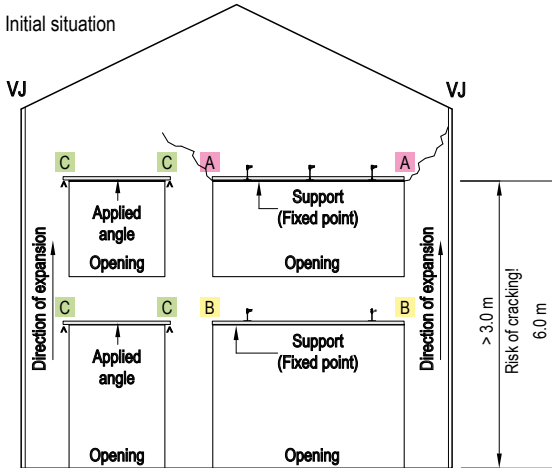

▲ Facing extends over 6 m or two storeys

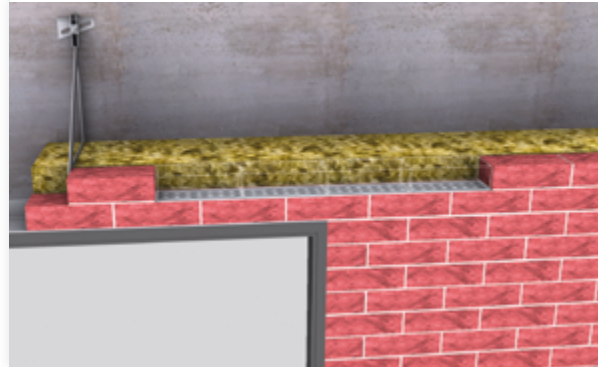

▲ Proposal for situation B perforated tape layers in the bearing joint of the transition window in pier

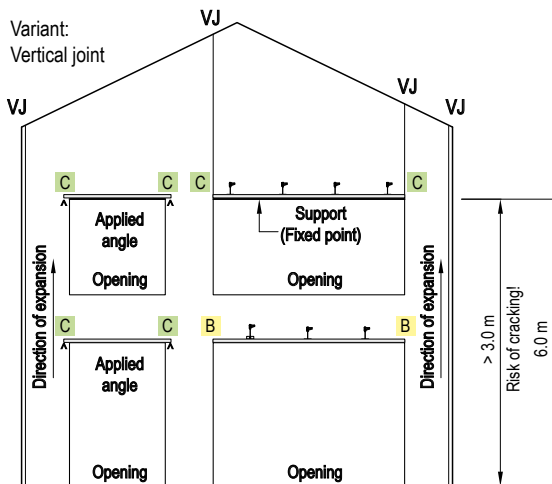

▲ The surfaces separated by the vertical joints can freely move differently from each other

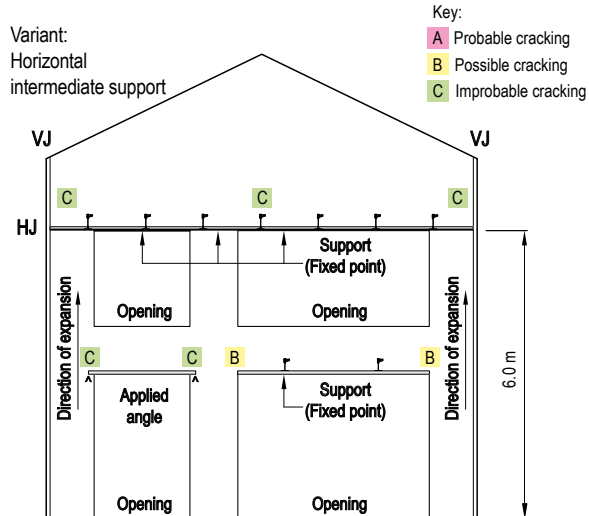

▲ The expansion after 6 m from the pier is absorbed by the permanently elastic horizontal joint

Expansion joint formation

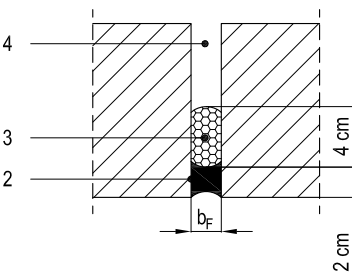

$$b_F \geq 1,5 \cdot \text{Distance between expansion joints} / 1000$$

▲ Formation of a vertical expansion joint

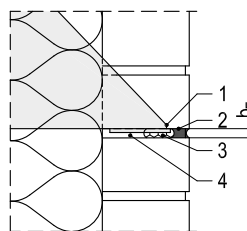

$$b_F \geq 2 \cdot \text{Distance between expansion joints} / 1000$$

▲ Formation of a horizontal expansion joint under support bracket

- 1 Support bracket
- 2 Elastoplastic joint sealant
- 3 Backing material (round foam profile)
- 4 Expansion joint



Assembly instructions for MOSO® FB-DV 4.0 / 8.0 kN

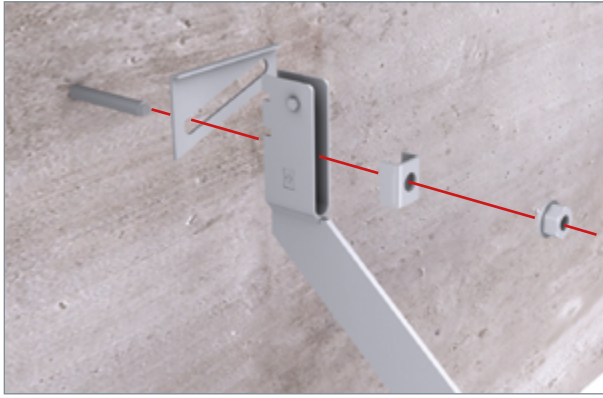

▲ Insert the dowels after approval, place the slotted hole plate and support anchor on the dowel anchor rod.

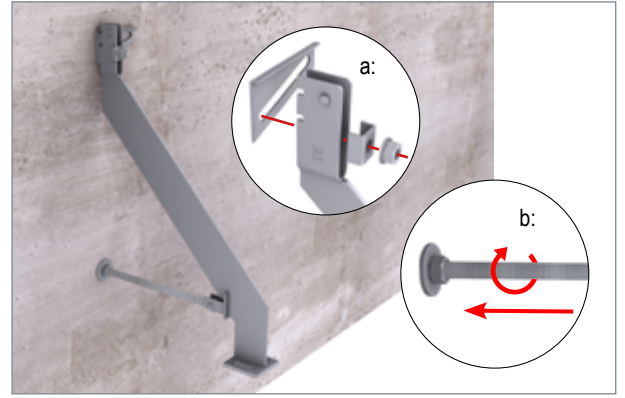

▲ a: Position the cranked U-washer and pre-assemble it by hand using a SKM hexagon nut.
b: Adjust pressure screw to cavity width

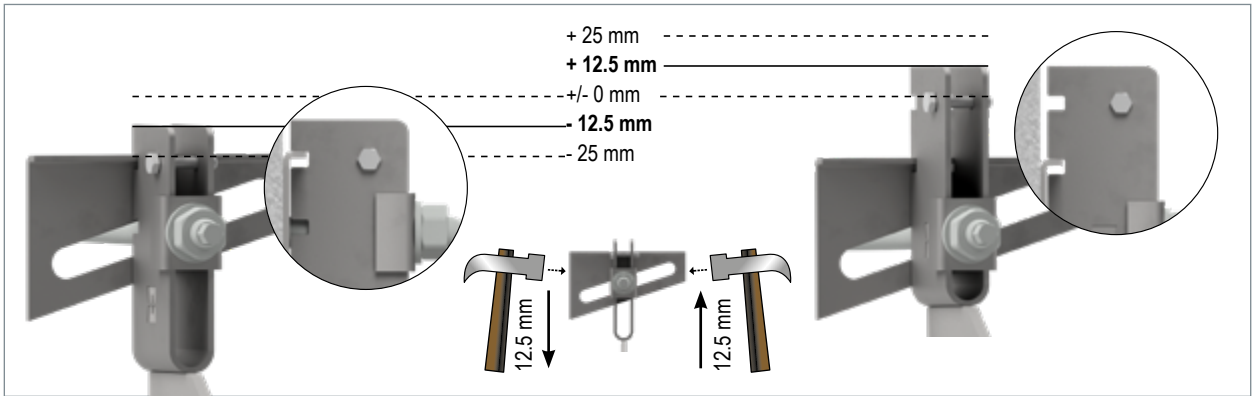

▲ Roughly adjust the height of the support anchor by moving the cranked slotted hole plate and adjust it by moving the slotted hole plate.

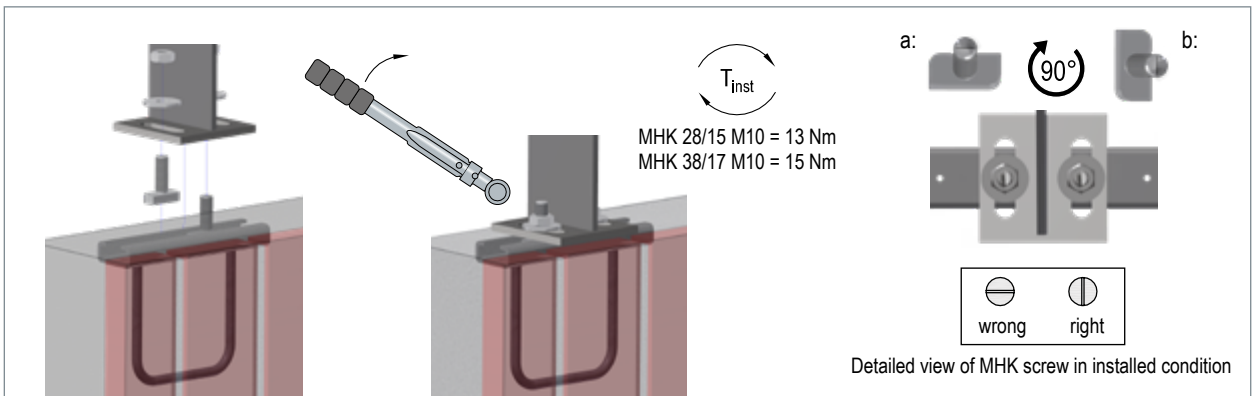

▲ Insert the MHK hammer head screws with their head parallel to the anchor rail (a). Turn the MHK screws in a clockwise direction until the notch at the end of the screw is parallel to the slot of the mounting plate (b). Place the mounting plate of the console, U-washers and hexagon nuts on the MHK screw and tighten by hand. Align the finished part with the shell clearance. Tighten the hammer head screw by applying the tightening torque.

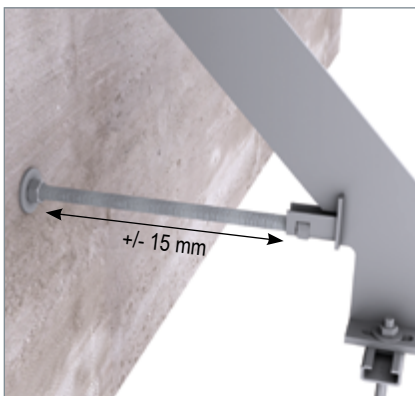

▲ Adjust the pressure screw until it is flush against the shell.

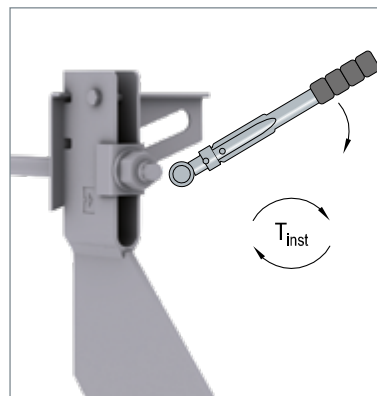

▲ Apply the tightening torque in accordance with the dowel approval.

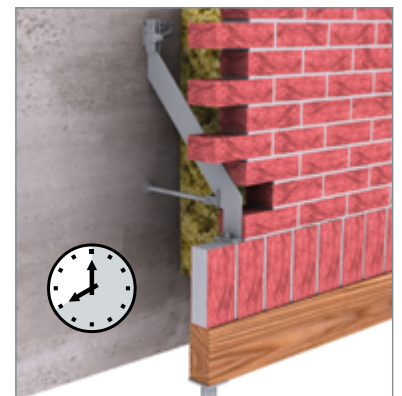

▲ Only remove local supports once the masonry mortar has completely hardened!

Assembly instructions for MOSO® WK-NV 4.0 / 8.0 kN

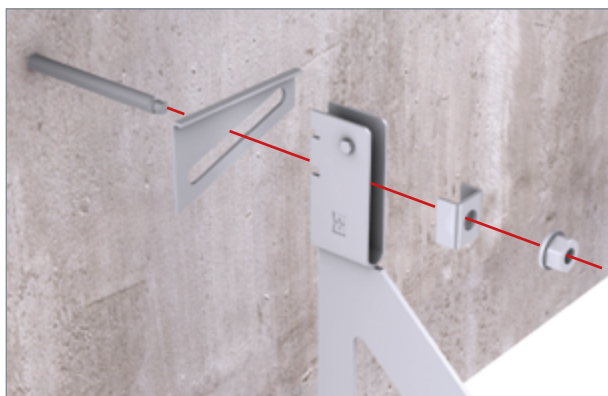

▲ Insert the dowels after approval, place the slotted hole plate and support anchor on the dowel anchor rod.



▲ Position the cranked U-washer and pre-assemble it by hand using a SKM hexagon nut.

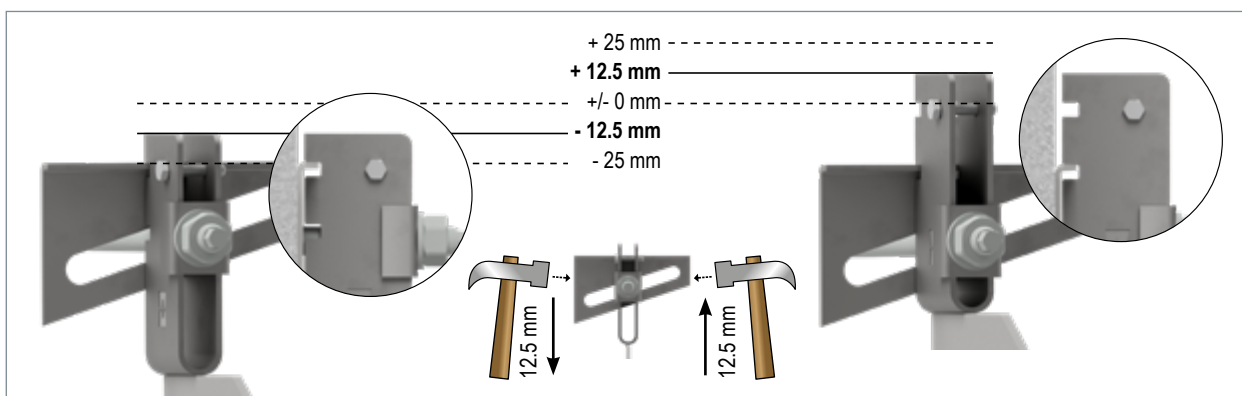

▲ Roughly adjust the height of the support anchor by turning over the slotted hole plate (position a or b) and adjust it by moving the slotted hole plate.

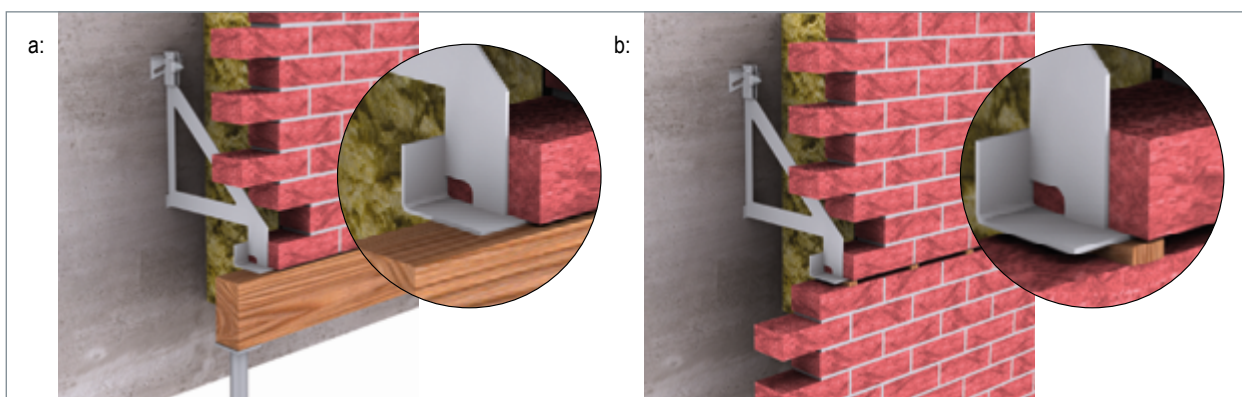

▲ Before starting the brick construction:
 a: Support the angle bracket entirely, e.g. by wooden beams, and sufficiently prop up force-fitted with supports or similar.
 b: Aid the supporting angles punctually at short intervals, e.g. using plastic or wooden wedges.

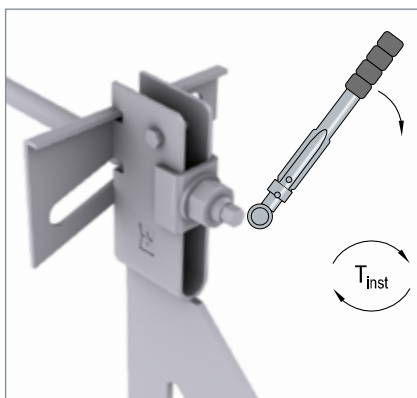

▲ Apply the tightening torque in accordance with the dowel approval.

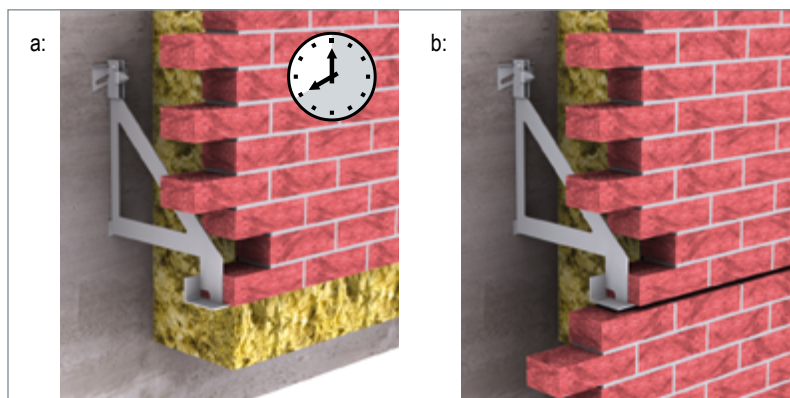

▲ a: Only remove local supports once the masonry mortar has completely hardened!
 b: Do not remove the spacers before complete curing of the brickwork.
 The intermediate space for the permanently elastic joint may not be connected by masonry mortar or similar.



Dimensioning principles

Selection of the anchoring system(*)

Type of bracing	Situation	Anchoring system
Plinth or intermediate support	Wall length < 3 m and corners	Angle-bracket anchor
Plinth or intermediate support	Wall length > 3 m	Single-bracket anchors
Lintel overlap (visible)	Width of opening < 2.01 m	Angle bearing
Lintel overlap (visible)	Width of opening < 2.01 m	Angle-bracket anchor
Lintel overlap (invisible)	Brickwork < 0.5 m	Single-bracket anchor EK-G
Lintel overlap (invisible)	Width of opening ≤ 2,51 m Brickwork ≤ 0.42 m	Moso perforated strip
Lintel overlap (invisible)	Width of opening < 2.51 m	Angle-bracket anchor with wire binder
Lintel overlap (with precast facing lintel)		Fixings for precast parts or laid on

(*) This table generally constitutes a recommendation. Since we offer planning and production as a one-stop-shop, we are already in a position to carry out a cost-benefit analysis while planning the project, so that we can provide you with an optimal offer.

Selection of the anchoring system(*)

Anchoring system	Advantages	Disadvantages
Anchor channel, concreted in in-situ concrete	<ul style="list-style-type: none"> • short installation times for bracing constructions 	<ul style="list-style-type: none"> • higher material costs • early planning required • precise in-situ concrete preparation necessary
Approved dowels, subsequently placed in the in-situ concrete	<ul style="list-style-type: none"> • dowels can be placed immediately before installation • low material costs 	<ul style="list-style-type: none"> • longer installation times due to dowel hole drilling

(*) We usually recommend that our customers use dowels, as - in our experience - these serve the practical construction flow requirements better.

Validation of the support construction

Calculation of the resulting distribution force R	
D compressive force [kN]	$= Z = F_v \times (a / (b - 0,5 x j))$
R resulting anchor force [kN]	$= \sqrt{F_v^2 + D^2}$
F_v Load per support bracket	
Z tensile force	
a load lifting arm [mm]	$= E + k/2 + 10$
b anchoring lifting arm [mm]	$= x - 10$ (regular)
j adjustment option total [50 mm]	

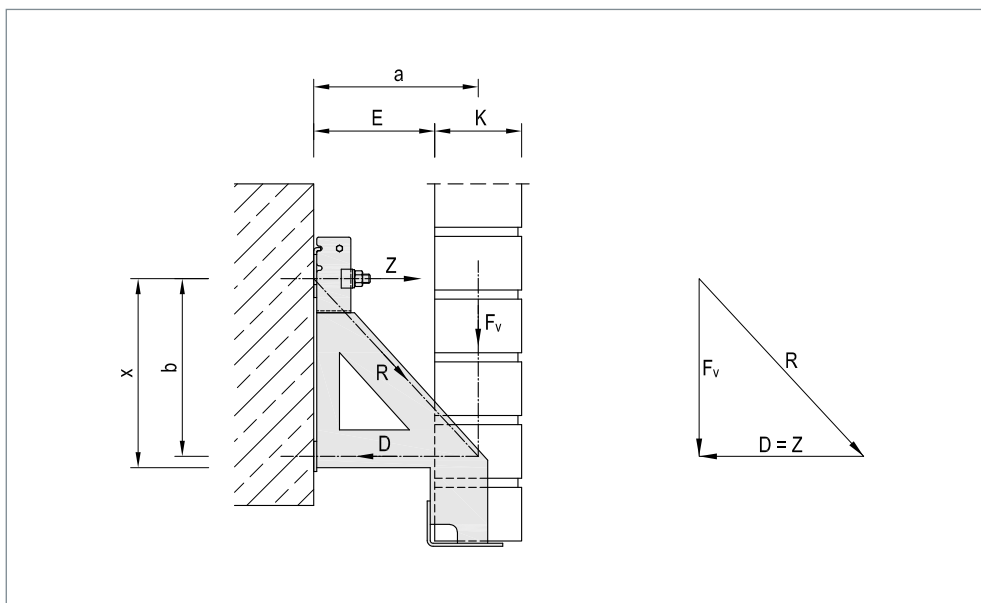

The decisive variables for the validation of fixings are - depending on the approval - the anchor force R or the tensile force Z and the lateral force F_v .

In any case, the approval condition must be observed.

Surface treatment

Treatment of stainless steel surfaces



The fixing parts supplied by us are made of high-quality stainless steel acc. to Eurocode 3 (DIN EN 1993-1-4) and type approvals of the German Institute for Structural Engineering. We are happy to provide you with a factory certification (version 3.1) at any time on request, which provides information on mechanical properties and chemical composition of the supplied steel.

In our production, the parts are blasted or stained, so that the passive layer immediately rebuilds after mechanical treatment, and regular steel abrasion on the surface of the stainless steel parts is excluded.

If any stains form on the surface on-site despite our efforts, these are not indicative of the actual resistance and capacity of the stainless steel supplied by us.

Please find a summary of common causes of marks or stains on stainless steel items:

1. During transport / unloading:

The carrier driver takes the parts out of the packaging when unloading, and pulls them over the unprotected loading edge made from regular steel. In this process, some regular steel is transferred onto the surfaces of the stronger stainless steel - even with only slight pressure. These abrasion particles corrode during storage in humid environments (e.g. outside) and can be seen on the stainless steel article.

Of course, this issue also arises if conveyors or lifting gears made of regular steel touch the stainless steel surface. For instance, if parts are hung in a crane chain without a protective layer between the regular steel chains and the stainless steel parts. At the contact points, a brown abrasion mark will occur on the stainless steel parts when humidity is at play.

2. During intermediate storage:

The unprotected stainless steel parts must not be stored directly next to - and especially not on top or underneath of - regular steel parts. As described above, direct contact will lead to regular steel abrasion on the stainless steel parts. If stored next to one another outside, exposed to wind and rain, "flash rust" is formed. This falls onto the stainless steel parts and can be removed easily by wiping the parts down. If stainless steel and regular steel are stored in immediate proximity, a sheet as protective separation is recommended.

Care should also be taken that no work on steel parts is carried out near the stainless steel parts. For instance, cutting regular steel profiles with a flex may result in glowing sparks flying long distances, and these are a common cause for later mark formation on the stainless steel parts. The big issue with this contamination is that the regular steel particles burn into the stainless steel surface.

3. During installation:

"The supporting angles should be supported until the mortar has fully set." That's what our installation instructions for the brick support say. But regular steel brackets should definitely not be used for this support. Naturally, regular steel abrasion happens here as well; and especially with the visible bracings near the windows, it can ruin the entire appearance. We therefore recommend using a piece of wood for this support - one that hasn't been in contact with regular steel, and which hasn't been treated. Impregnation can attack stainless steel.

Please take care during installation that no regular steel equipment or splashes contact the stainless steel surface during processing, which may cause abrasion or burning on the stainless steel parts. Even a slight knock with a hammer made from regular tool steel, or a grip with some pliers is enough. If you need to use these tools, please ensure you use chromed or - ideally - tools not made from tool steel.

4. During subsequent facade works:

Acid washing the brick wall - often done with diluted hydrochloric acid or an agent containing hydrochloric acid - can be very problematic for stainless steel. Hydrochloric acid is one of the most aggressive materials for any metal materials. This is why these agents should not be used near the facade, where it comes into direct contact with the stainless steel, or where it might be blown by wind or splashed during application.

We recommend not carrying out the traditional acid wash with diluted hydrochloric acid, and to follow recommendations of relevant specialist firms and associations instead. However, if diluted hydrochloric acid does come into contact with the lower sides of the bracings due to a lack of knowledge on modern cleaning methods, it must be rinsed of with clean water immediately (within a few minutes).

If acid remnants have soaked into the stainless steel parts for longer, the resulting marks constitute a purely visual impairment. Any brown colourings can then be removed with a special passivating agent, especially on visible window lintels. The passivating agent must also be removed thoroughly after application by rinsing the surface with clean water. The passivating agent is described in more detail below:

Measures to remove marks through abrasion, flash rust, acid impact or contact with impregnated woods:

It is not always possible to remove contamination accumulated on the stainless steel by wiping these down with a cloth, even if through airborne particles. The particles are embedded in the pores of the metal surface, or rubbed in by rubbing or brushing the surface. Even if cold-pressed plate surfaces appear, these pores exist, so that the brown colouration will reappear after wiping or brushing in contaminated by regular steel.

Their removal requires a passivating agent which contains nitric acid. Nitric acid is an oxidising acid. Nitric acid therefore accelerates the formation of a passive layer on the surface of the stainless steel. In addition to cleaning the surface from undesirable regular steel and dirt residues, the composition with nitric acid promotes stainless steel resistance without attacking the surface. Once applied for a certain period, the passivating agent must be thoroughly rinsed off with clean water.

Of course, coarse contaminations can be removed first with a stainless steel wire brush or a stainless steel pickling paste. The stainless steel pickling paste must be applied with a brush and then rinsed off with clean water. The pickling paste is very aggressive, and must only be applied with suitable protective clothing, such as protective gloves, aprons and protective goggles to prevent bodily injuries.

Surface damage on the stainless steel parts can be removed with a special rough grinder or mop wheel fitted onto your drill. However, it should be noted that this causes damage to the stainless steel part, and the passive layer will only reform several days later. Of course, the passivating process can be accelerated significantly with the aforementioned passivating agent.

Agents for surface treatment and protective clothing

• Passivating agent RP-GEL	Item no.	140414
• Cleaning agent plus 3000	Item no.	140425
• Surface protection OS 540	Item no.	140426
• Brush mordant TS a 2 kg	Item no.	140422
• Acid-resistant plastic mordant brush	Item no.	140418
• Acid protection gloves	Item no.	140513
• Acid-proof apron	Item no.	140362
• Nylon protective goggles, shatterproof	Item no.	140363
• Stainless steel wire hand brush	Item no.	140417
• Stainless steel pot brush for power drill	Item no.	140061
• Roughing disc for hand angle grinder, 180 mm Ø	Item no.	140390
• Roughing disc for hand angle grinder, 115 mm Ø	Item no.	140391
• Abrasive mop wheel disc, for hand angle grinder 178 mm Ø	Item no.	140392
• Abrasive mop wheel disc, for hand angle grinder 115 mm Ø	Item no.	140393



MODERSOHN®
Stainless Steel

Experience & expertise



Competent advice
for individual solutions



modersohn.eu

Leviat
A CRH COMPANY

The home of:



Wilhelm Modersohn GmbH & Co. KG (Teil von Leviat)
Industriestraße 23 • 32139 Spenge
Tel: +49 5225 8799-0 • Fax: +49 5225 6710
info@modersohn.de • www.modersohn.eu

Leviat-Products:

Leviat GmbH
Liebigstr. 14 • 40764 Langenfeld
Tel: +49 2173 970-0 • vertrieb@leviat.com